

Maschinenschraubstöcke

Machine vices

Étaux de machines

MASCHINENSCHRAUBSTÖCKE

MACHINE VICES

ÉTAUX POUR MACHINES





Präzisionsschraubstöcke

Precision vices
Étaux de précision

- ❶ Einzigartiges Spannbacken-System zur Erhöhung der Spannkraft
- ❷ Das patentierte Anti-Lift-System garantiert eine problemlose Bearbeitung, ohne Anhub des Werkstückes
- ❸ Spannkraft mit Hilfe von Rillenmarkierungen voreinstellbar
- ❹ Durch den mechanischen Spannkraftverstärker kann auch während extremer Arbeiten am Werkstück eine konstant hohe Spannkraft von bis zu 6500 kg erzielt werden
- ❺ Alle Verschleißteile sind gehärtet und geschliffen

- ❶ Unique clamping-jaw-system increases the clamping capacity
- ❷ The new Anti-Lift mechanism ensures that the workpiece does not lift during operations
- ❸ Clamping force preadjustable with the aid of graduation lines
- ❹ The mechanical Booster ensures that during extreme operations a constant high clamping-force up to 6500 kg can be reached
- ❺ All working parts are hardened and grinded

- ❶ Système unique de serrage des mâchoires pour la force de serrage élevée
- ❷ Système patenté Anti-Lift garantit l'usinage sans problème, sans que la pièce à usiner ne soit soulevée
- ❸ Force de serrage à l'aide de repères à rainures, pré-réglable
- ❹ Grâce à l'amplificateur de force de serrage mécanique, il est aussi possible d'obtenir la force de serrage élevée et constante jusqu'à 6500 kg, lors de travaux extrêmes sur la pièce
- ❺ Toutes les pièces d'usure sont trempées et rectifiées

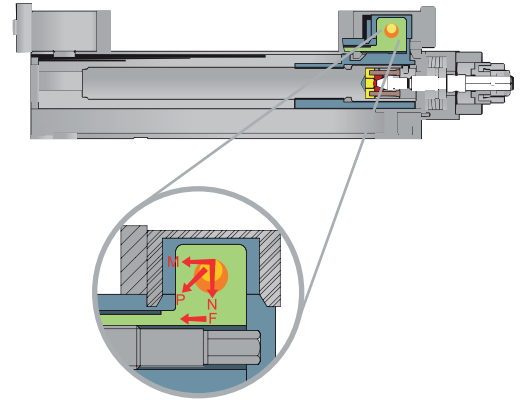

Durch das neue Anti-Lift-System werden die Werkstücke beim Spannen niedergezogen und präzise gespannt

By the new Anti-lift-system workpieces get pulled-down and precisely clamped

Grâce au nouveau système anti-levage, les pièces à usiner sont tirées vers le bas lors du serrage et serrées de manière précise

Allseitig gehärtet und geschliffen
All-round hardened and grinded
Complètement trempé et rectifié

Stabiler Späneschutz
Solid chip protector
Protection solide contre les copeaux

Spannkraft voreinstellbar
Clamping force preadjustable
Force de serrage pré-réglée

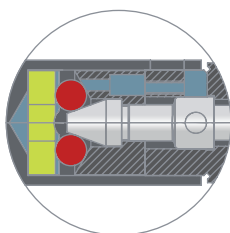
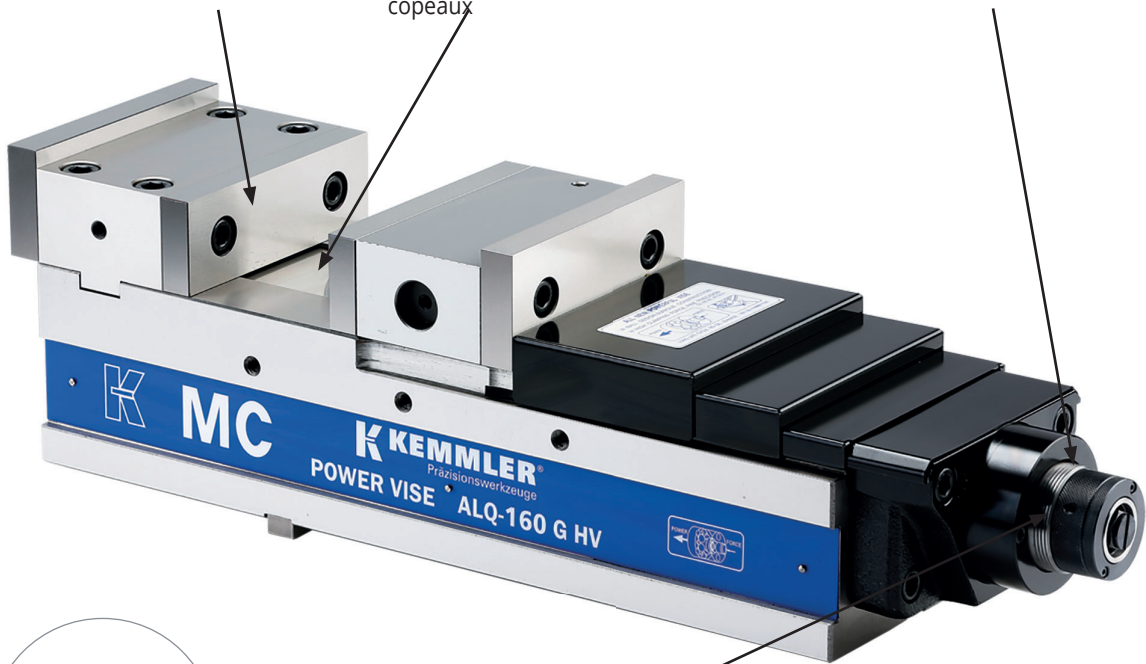

Mechanischer Spannkraftverstärker
Mechanical Booster
Amplificateur de la force de serrage mécanique

11.05 	11.06 	11.07 	11.08 
11.09 	11.10 	11.11 	11.12 
11.13 	11.14 	11.15 	11.16 
11.17 	11.19 	11.20 	11.21 
11.23 	11.24 	11.25 	11.29 
11.30 	11.30 	11.31 	11.35 
11.40 	11.41 	11.42 	11.47 
11.48 			



Präzisionsschraubstöcke mechanisch mit Spannkraftverstärker

Precision vices mechanical with mechanical booster

Étaux de précision mécaniques avec l'amplificateur de la force de serrage

Ausführung:

- Mit mechanischem Spannkraftverstärker
- Spannkraft voreinstellbar durch Rillenmarkierung
- Horizontal, vertikal oder seitlich aufspannbar
- Stahlkörper allseitig geschliffen und gehärtet
- Eingebauter Niederzug
- Betthöhe H: $\leq 0,01$ mm

Lieferumfang:

- Bedienungsanleitung
- Incl. Spannschlüssel
- 4 Stück Spannpratzen
- 4 Stück T-Nutensteine 18mm
- Messprotokoll

Spannkraft:

KS01010 = 45 kN
KS01020 = 50 kN

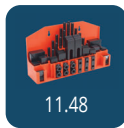
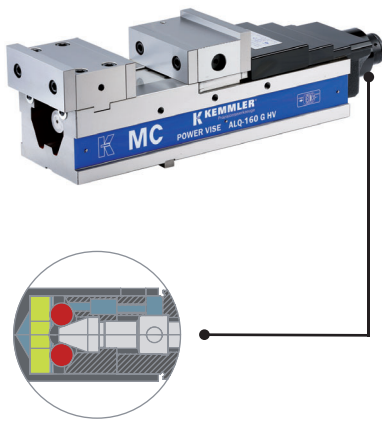

Construction:

- With mechanical booster
- Clamping force preadjustable by graduation lines
- Clamping positions: horizontal, vertical and lateral
- The steel body is hardened and grinded all-round
- Integrated pull-down mechanism
- Bed height H: $\leq 0,01$ mm

Delivery:

- Instructions for use
- Wrench
- 4 pcs. vice clamps
- 4 pcs. T-nuts 18mm
- Test certificate

Clamping force:

KS01010 = 45 kN
KS01020 = 50 kN

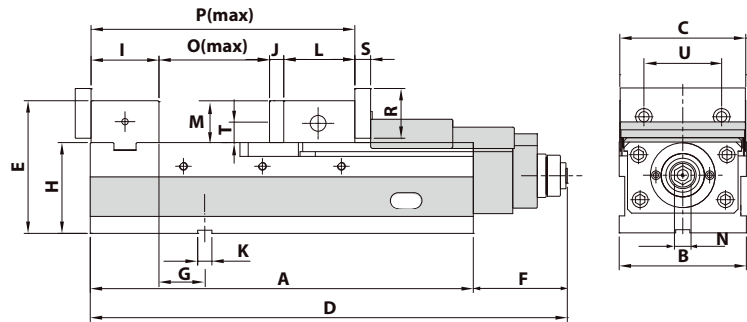
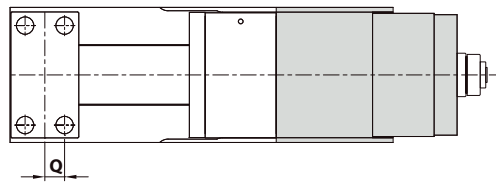

Version:

- Avec l'amplificateur de la force de serrage mécanique
- Force de serrage pré-réglable par le marquage des rainures
- Positions de serrage: horizontale, verticale ou latérale
- Corps en acier trempé et rectifié de tous côtés
- Mécanisme de traction vers le bas intégré
- Hauteur du socle H: $\leq 0,01$ mm

Livraison avec:

- Mode d'emploi
- Clé de serrage
- 4 Mors de serrage
- 4 Tasseaux pour rainures en T 18mm
- Protocole de mesure

Force de serrage:

KS01010 = 45 kN
KS01020 = 50 kN

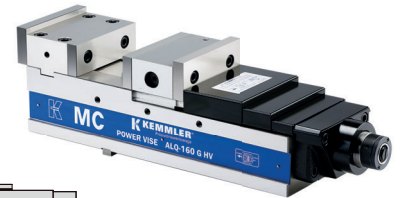

11

Mit patentiertem mechanischem Spannkraftverstärker:

- kein Ölverlust
- genaue Wiederholbarkeit der Spannkraft
- keine Veränderung der Spannkraft
- keine Vibrationen während der Bearbeitung
- lange Lebensdauer

With patented mechanical booster:

- no loss of oil
- exact repeatability of the clamping force
- constant clamping force
- no vibrations during the operation
- long life

Avec l'amplificateur de la force de serrage mécanique patenté:

- pas de perte d'huile
- la répétition précise de la force de serrage
- pas de changement de la force de serrage
- pas de vibrations pendant l'usage
- longue durée de vie

Bestell-Nr. Order no. Référence	Typ	A	B	C	D	E	F	G	H	I	J	K	L	M	N	O	P	Q	R	S	T	U	kN	kg	EUR
KS01010	ALQ-160	515	161	159,5	603	168	88	76	115	86	18	18	80	53	19	330,0	514,0	25	63	20	26,5	98,4	45	76	2.444,00*
KS01020	ALQ-200	585	202	200,0	673	178	88	93	120	101	18	18	95	58	19	367,5	581,5	31	73	20	29	120	50	108	2.804,00*

* zzgl. Speditionskosten
* extra shipping costs
* frais de port supplémentaires

Precision vices mechanical with mechanical booster

Étaux de précision mécanique avec l'amplificateur de la force de serrage

Ausführung:

- Mit mechanischem Spannkraftverstärker
- Spannkraft voreinstellbar durch Rillenmarkierung
- Horizontal, vertikal oder seitlich aufspannbar
- Stahlkörper allseitig geschliffen und gehärtet
- Eingebauter Niederzug
- Betthöhe H: $\leq 0,01$ mm

Lieferumfang:

- Bedienungsanleitung
- Incl. Spannschlüssel
- 4 Stück Spannpratzen
- 4 Stück T-Nutensteine 18mm
- Messprotokoll

Spannkraft:

KS02010 = 25 kN
 KS02020 = 35 kN
 KS02030 = 45 kN
 KS02040 = 50 kN

Construction:

- With mechanical booster
- Clamping force preadjustable by graduation lines
- Clamping positions: horizontal, vertical and lateral
- The steel body is hardened and grinded all-round
- Integrated pull-down mechanism
- Bed height H: $\leq 0,01$ mm

Delivery:

- Instructions for use
- Wrench
- 4 pcs. vice clamps
- 4 pcs. T-nuts 18mm
- Test certificate

Clamping force:

KS02010 = 25 kN
 KS02020 = 35 kN
 KS02030 = 45 kN
 KS02040 = 50 kN

Version:

- Avec l'amplificateur de la force de serrage mécanique
- Force de serrage pré-réglable par le marquage des rainures
- Positions de serrage: horizontale, verticale ou latérale
- Corps en acier trempé et rectifié de tous côtés
- Mécanisme de traction vers le bas intégré
- Hauteur du socle H: $\leq 0,01$ mm

Livraison avec:

- Mode d'emploi
- Clé de serrage
- 4 Mors de serrage
- 4 Tasseaux pour rainures en T 18mm
- Protocole de mesure

Force de serrage::

KS02010 = 25 kN
 KS02020 = 35 kN
 KS02030 = 45 kN
 KS02040 = 50 kN

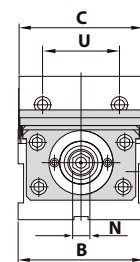
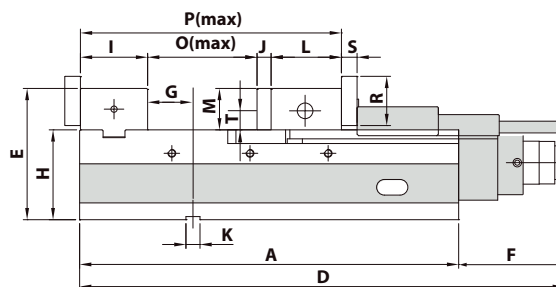
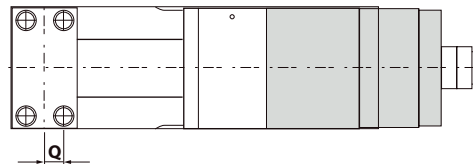
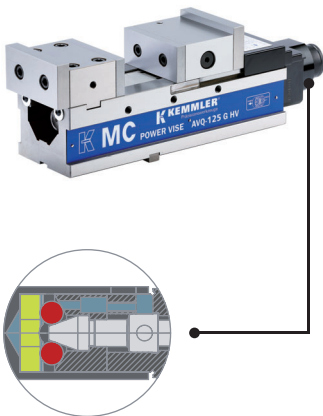

Mit patentiertem mechanischem Spannkraftverstärker:

- kein Ölverlust
- genaue Wiederholbarkeit der Spannkraft
- keine Veränderung der Spannkraft
- keine Vibrationen während der Bearbeitung
- lange Lebensdauer

With patented mechanical booster:

- no loss of oil
- exact repeatability of the clamping force
- constant clamping force
- no vibrations during the operation
- long life

Avec l'amplificateur de la force de serrage mécanique patenté:

- pas de perte d'huile
- la répétition précise de la force de serrage
- pas de changement de la force de serrage
- pas de vibrations pendant l'usage
- longue durée de vie

Bestell-Nr. Order no. Référence	Typ	A	B	C	D	E	F	G	H	I	J	K	L	M	N	O	P	Q	R	S	T	U	kN	kg	EUR
KS02010	AVQ-100	324	104	102	412	130	88	41	85	73	15	18	86,5	45	19	140	314,5	20	55	20	22,5	58	25	30	1.635,00*
KS02020	AVQ-125	390	127	125	478	153	88	66	100	78	15	18	87,5	53	19	201	381,5	22,5	63	20	26,5	60	35	46	1.801,00*
KS02030	AVQ-160	485	161	159,5	573	168	88	58	115	86	18	18	80	53	19	295	479	25	63	20	26,5	98,4	45	71	2.277,00*
KS02040	AVQ-200	535	202	200	623	178	88	75	120	101	18	18	95	58	19	320	534	31	73	20	29	120	50	100	2.638,00*

* zzgl. Speditionskosten | * extra shipping costs | * frais de port supplémentaires



Präzisionsschraubstöcke mechanisch mit Spannkraftverstärker

Precision vices mechanical with mechanical booster

Étaux de précision mécanique avec l'amplificateur de la force de serrage

Ausführung:

- Mit mechanischem Spannkraftverstärker
- Spannkraft voreinstellbar durch Rillenmarkierung
- Horizontal und vertikal aufspannbar
- Stahlkörper allseitig geschliffen und gehärtet
- Eingebauter Niederzug
- Betthöhe H: $\leq 0,01$ mm

Lieferumfang:

- Bedienungsanleitung
- Incl. Spannschlüssel
- 4 Stück Spannpratzen
- 4 Stück T-Nutensteine 18mm
- Messprotokoll

Spannkraft:

KS14010 = 45 kN

Construction:

- With mechanical booster
- Clamping force preadjustable by graduation lines
- Clamping positions: horizontal and vertical
- The steel body is hardened and grinded all-round
- Integrated pull-down mechanism
- Bed height H: $\leq 0,01$ mm

Delivery:

- Instructions for use
- Wrench
- 4 pcs. vice clamps
- 4 pcs. T-nuts 18mm
- Test certificate

Clamping force:

KS14010 = 45 kN

Version:

- Avec l'amplificateur de la force de serrage mécanique
- Force de serrage pré-réglable par le marquage des rainures
- Positions de serrage: horizontale et verticale
- Corps en acier trempé et rectifié de tous côtés
- Mécanisme de traction vers le bas intégré
- Hauteur du socle H: $\leq 0,01$ mm

Livraison avec:

- Mode d'emploi
- Clé de serrage
- 4 Mors de serrage
- 4 Tasseaux pour rainures en T 18mm
- Protocole de mesure

Force de serrage:

KS14010 = 45 kN

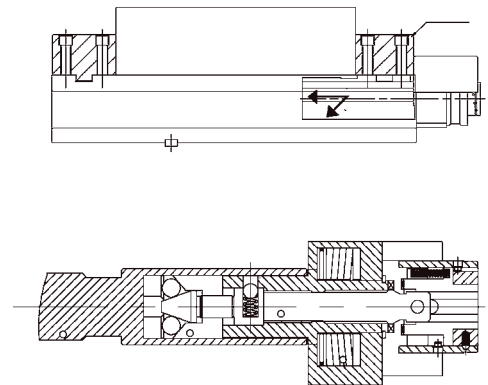
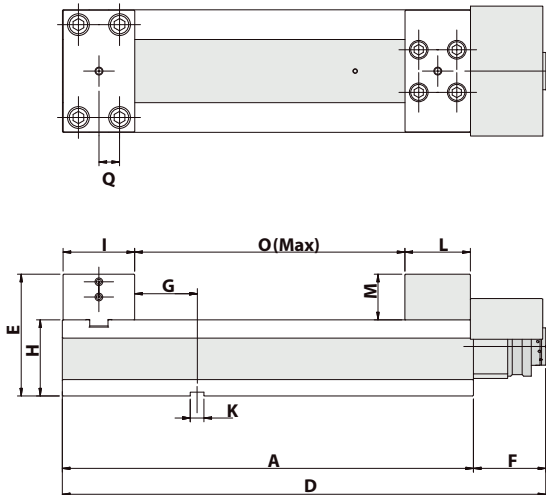
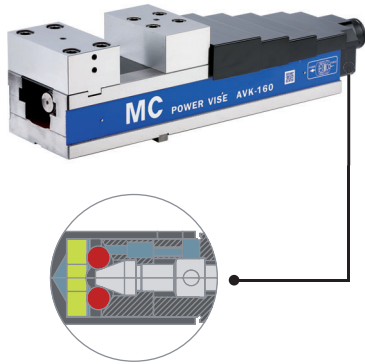

11



Bestell-Nr. Order no. Référence	Typ	A	B	C	D	E	F	G	H	I	K	M	N	O	Q	kN	kg	EUR
KS14010	AVK-160	540	161	160	628	160	88	82	100	94	18	60	14	355	27	45	65	2.830,00*

* zzgl. Speditionskosten | * extra shipping costs | * frais de port supplémentaires

Precision vices self-centering mechanical Étaux de précision auto-centrés mécaniques

Ausführung:

- Horizontal, vertikal oder seitlich aufspannbar
- Stahlkörper allseitig geschliffen und gehärtet
- Eingebauter Niederzug
- Betthöhe H: $\leq 0,01$ mm

Construction:

- Clamping positions: horizontal, vertical and lateral
- The steel body is hardened and grinded all-round
- Integrated pull-down mechanism
- Bed height H: $\leq 0,01$ mm

Version:

- Positions de serrage: horizontale, verticale ou latérale
- Corps en acier trempé et rectifié de tous côtés
- Mécanisme de traction vers le bas intégré
- Hauteur du socle H: $\leq 0,01$ mm

Lieferumfang:

- Bedienungsanleitung
- Incl. Spannschlüssel
- 4 Stück Spannpratzen
- 4 Stück T-Nutensteine 18mm
- Messprotokoll

Delivery:

- Instructions for use
- Wrench
- 4 pcs. vice clamps
- 4 pcs. T-nuts 18mm
- Test certificate

Livraison avec:

- Mode d'emploi
- Clé de serrage
- 4 Mors de serrage
- 4 Tasseaux pour rainures en T 18mm
- Protocole de mesure

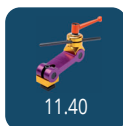
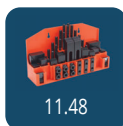
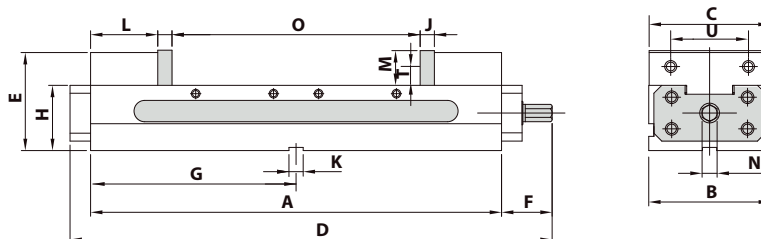
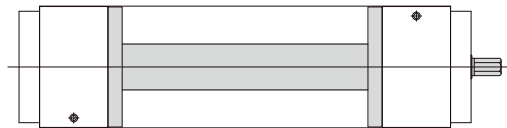
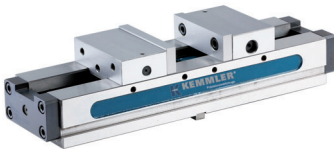

Bestell-Nr. Order no. Référence	Typ	A	B	C	D	E	F	G	H	J	K	L	M	N	O	T	U	kg	EUR
KS19010	HLD-60	520	154	152	610	124,05	64	260	82,55	18	18	86,5	44,5	19	58-314	23,8	98,4	52	2.444,00*

* zzgl. Speditionskosten | * extra shipping costs | * frais de port supplémentaires



Präzisionsschraubstöcke mechanisch mit Spannkraftverstärker

Precision vices mechanical with mechanical booster

Étaux de précision mécanique avec l'amplificateur de la force de serrage

Ausführung:

- Mit mechanischem Spannkraftverstärker
- Spannkraft voreinstellbar durch Rillenmarkierung
- Horizontal, vertikal oder seitlich aufspannbar
- Stahlkörper allseitig geschliffen und gehärtet
- Eingebauter Niederzug
- Betthöhe H: $\leq 0,01$ mm

Lieferumfang:

- Bedienungsanleitung
- Incl. Spannschlüssel
- 4 Stück Spannpratzen
- 4 Stück T-Nutensteine 18mm
- Messprotokoll

Spannkraft:

KS15010 = 45 kN
KS15020 = 60 kN

Construction:

- With mechanical booster
- Clamping force preadjustable by graduation lines
- Clamping positions: horizontal, vertical and lateral
- The steel body is hardened and grinded all-round
- Integrated pull-down mechanism
- Bed height H: $\leq 0,01$ mm

Delivery:

- Instructions for use
- Wrench
- 4 pcs. vice clamps
- 4 pcs. T-nuts 18mm
- Test certificate

Clamping force:

KS15010 = 45 kN
KS15020 = 60 kN

Version:

- Avec l'amplificateur de la force de serrage mécanique
- Force de serrage pré-réglable par le marquage des rainures
- Positions de serrage: horizontale, verticale ou latérale
- Corps en acier trempé et rectifié de tous côtés
- Mécanisme de traction vers le bas intégré
- Hauteur du socle H: $\leq 0,01$ mm

Livraison avec:

- Mode d'emploi
- Clé de serrage
- 4 Mors de serrage
- 4 Tasseaux pour rainures en T 18mm
- Protocole de mesure

Force de serrage:

KS15010 = 45 kN
KS15020 = 60 kN

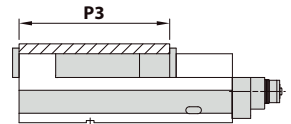
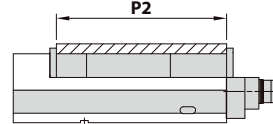
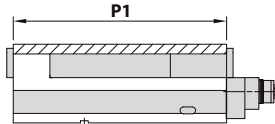
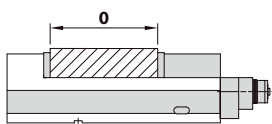
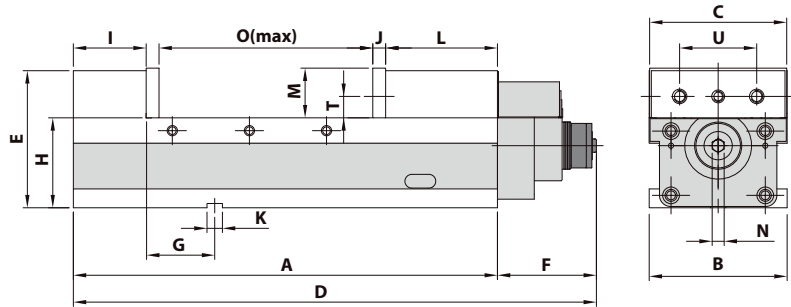
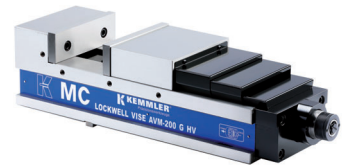
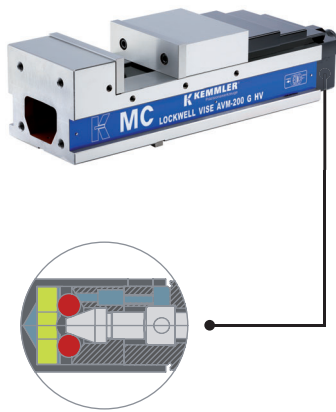

11

Bestell-Nr. Order no. Référence	Typ	A	B	C	D	E	F	G	H	I	J	K	L	M	N	O	P1	P2	P3	T	U	kN	kg	EUR
KS15010	AVM-160	495	161	160	583	160	88	80	105	85	15	18	130	58	19	245	250-480	250-370	250-330	25	90	43	55	2200,00*
KS15020	AVM-200	580	201	200	708	170	128	100	110	90	18	18	150	63	19	290	290-550	290-430	290-370	28	120	60	78	2585,00*

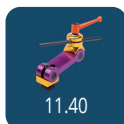
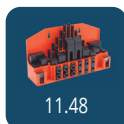

* zzgl. Speditionskosten
* extra shipping costs
* frais de port supplémentaires

Precision vices mechanical Étaux de précision mécanique

Ausführung:

- Horizontal, vertikal oder seitlich aufspannbar
- Stahlkörper allseitig geschliffen und gehärtet
- Eingebauter Niederzug
- Betthöhe H: $\leq 0,01$ mm

Construction:

- Clamping positions: horizontal, vertical and lateral
- The steel body is hardened and grinded all-round
- Integrated pull-down mechanism
- Bed height H: $\leq 0,01$ mm

Version:

- Positions de serrage: horizontale, verticale ou latérale
- Corps en acier trempé et rectifié de tous côtés
- Mécanisme de traction vers le bas intégré
- Hauteur du socle H: $\leq 0,01$ mm

Lieferumfang:

- Bedienungsanleitung
- Incl. Spannschlüssel
- 4 Stück Spannpratzen
- 4 Stück T-Nutensteine 18mm
- Messprotokoll

Delivery:

- Instructions for use
- Wrench
- 4 pcs. vice clamps
- 4 pcs. T-nuts 18mm
- Test certificate

Livraison avec:

- Mode d'emploi
- Clé de serrage
- 4 Mors de serrage
- 4 Tasseaux pour rainures en T 18mm
- Protocole de mesure

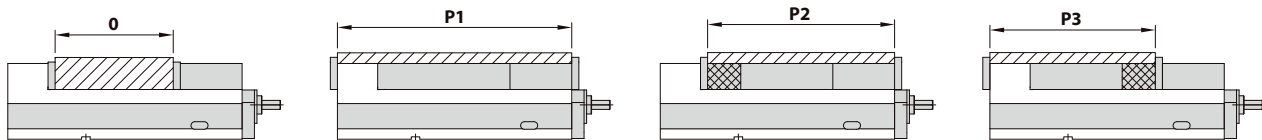
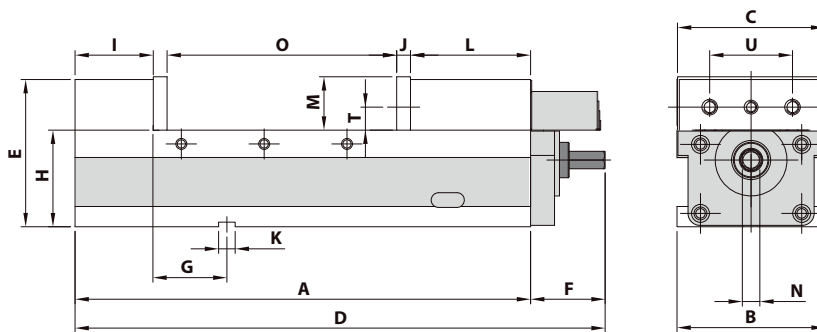

Bestell-Nr.

Order no.

Référence Typ

	A	B	C	D	E	F	G	H	I	J	K	L	M	N	O	P1	P2	P3	T	U	kg	EUR	
KS16010	AVC-160	495	161	160	576	160	81	80	105	85	15	18	130	58	19	245	250-480	250-370	250-330	25	90	52	2.007,00*
KS16020	AVC-200	580	201	200	670	170	90	85	110	90	18	18	130	63	19	250	290-550	290-430	290-370	28	120	75	2.406,00*

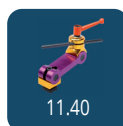

* zzgl. Speditionskosten

* extra shipping costs

* frais de port supplémentaires

K Präzisionsschraubstöcke mechanisch

Precision vices mechanical
Étaux de précision mécanique

Ausführung:

- Horizontal, vertikal oder seitlich aufspannbar
- Stahlkörper allseitig geschliffen und gehärtet
- Eingebauter Niederzug
- Betthöhe H: $\leq 0,01$ mm

Construction:

- Clamping positions: horizontal, vertical and lateral
- The steel body is hardened and grinded all-round
- Integrated pull-down mechanism
- Bed height H: $\leq 0,01$ mm

Version:

- Positions de serrage: horizontale, verticale ou latérale
- Corps en acier trempé et rectifié de tous côtés
- Mécanisme de traction vers le bas intégré
- Hauteur du socle H: $\leq 0,01$ mm

Lieferumfang:

- Bedienungsanleitung
- Incl. Spannschlüssel
- 4 Stück Spannpratzen
- 4 Stück T-Nutensteine 18mm
- Messprotokoll

Delivery:

- Instructions for use
- Wrench
- 4 pcs. vice clamps
- 4 pcs. T-nuts 18mm
- Test certificate

Livraison avec:

- Mode d'emploi
- Clé de serrage
- 4 Mors de serrage
- 4 Tasseaux pour rainures en T 18mm
- Protocole de mesure

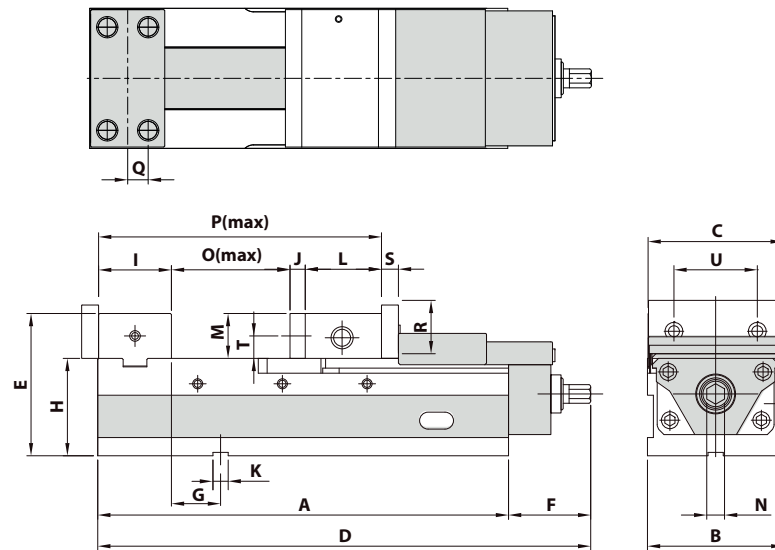

11

Bestell-Nr. Order no. Référence	Typ	A	B	C	D	E	F	G	H	I	J	K	L	M	N	O	P	Q	R	S	T	U	kg	EUR
KS05010	AVL-100	324	104	102,0	437	130	104	41	85	73	15	18	86,5	45	19	140	314,5	20,0	55	17	22,5	58	27	1.120,00
KS05020	AVL-125	390	127	125,0	480	153	105	66	100	78	15	18	87,5	53	19	201	381,5	22,5	63	20	26,5	60	43	1.275,00*
KS05030	AVL-160	485	161	159,5	625	168	120	76	115	86	18	18	80,0	53	21	295	479,0	25,0	63	20	26,5	98,4	71	1.699,00*
KS05040	AVL-200	535	202	199,5	660	178	128	93	120	101	18	18	95,0	58	19	320	534,0	31,0	73	20	29,0	120	98	2.753,00*

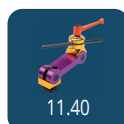

* zzgl. Speditionskosten
* extra shipping costs
* frais de port supplémentaires

Precision vices pneumatic hydraulic
Étaux de précision pneumatiques hydrauliques

Ausführung:

- Geeignet für Serienfertigung
- Horizontal und vertikal aufspannbar
- Stahlkörper allseitig geschliffen und gehärtet
- Betthöhe H: $\leq 0,01$ mm

Construction:

- Suitable for mass production
- Clamping positions: horizontal and vertical
- The steel body is hardened and grinded all-round
- Bed height H: $\leq 0,01$ mm

Version:

- Convient pour la production en série
- Positions de serrage: horizontale, ou verticale
- Corps en acier trempé et rectifié de tous côtés
- Hauteur du socle H: $\leq 0,01$ mm

Lieferumfang:

- Bedienungsanleitung
- Incl. Spannschlüssel
- 4 Stück Spannpratzen
- 4 Stück T-Nutensteine 18mm
- Messprotokoll

Delivery:

- Instructions for use
- Wrench
- 4 pcs. vice clamps
- 4 pcs. T-nuts 18mm
- Test certificate

Livraison avec:

- Mode d'emploi
- Clé de serrage
- 4 Mors de serrage
- 4 Tasseaux pour rainures en T 18mm
- Protocole de mesure

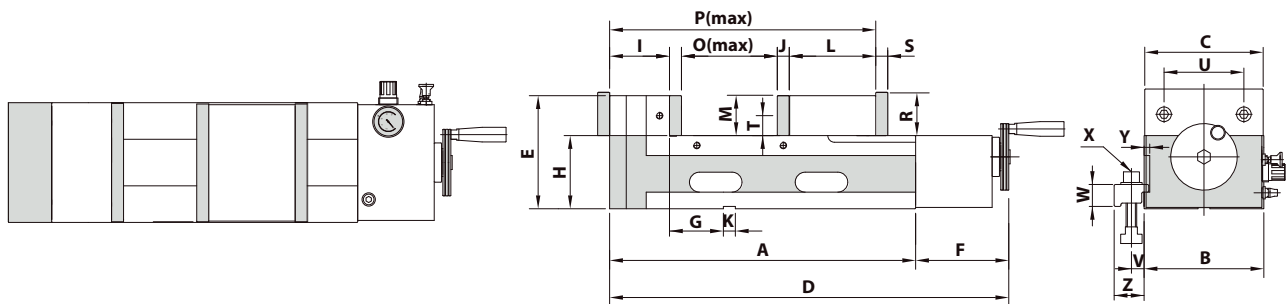
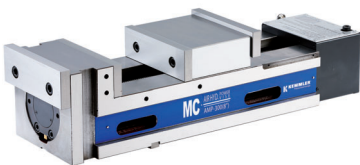

Bestell-Nr. Order no. Référence Typ	A	B	C	D	E	F	G	H	I	J	K	L	M	N	O	P	R	S	T	U	V	W	X	Y	Z	kN	kg	EUR
KS18150 AMP-150	380	130	128	505	157	125	45	105	85	15	18	110	52	-	150	200-380	62	20	25	90	17,5	33	M16x65L	8,5	43,5	62	52	3.049,00*
KS18160 AMP-160	400	160	158	525	160	125	45	105	87	15	18	120	55	-	160	210-400	62	20	25	90	16,5	33	M16x65L	9,5	42,5	62	58	3.421,00*
KS18165 AMP-165	490	160	158	615	160	125	45	105	87	15	18	120	55	-	250	210-490	65	20	25	90	16,5	33	M16x65L	9,5	42,5	62	65	3.626,00*
KS18180 AMP-180	460	180	178	585	170	125	72	110	90	18	18	130	60	-	200	220-460	70	20	28	120	15,5	33	M16x65L	12,5	39,5	90	75	3.821,00*
KS18200 AMP-200	470	200	200	595	170	125	72	110	90	18	18	140	60	-	200	230-470	70	20	28	120	15,5	33	M16x65L	12,5	39,5	90	82	4.026,00*
KS18300 AMP-300	570	200	200	695	170	125	72	110	90	18	18	140	60	-	300	230-570	70	20	28	120	15,5	33	M16x65L	12,5	39,5	90	93	4.438,00*

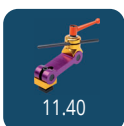
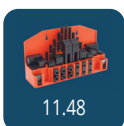

* zzgl. Speditionskosten
* extra shipping costs
* frais de port supplémentaires

K Doppelspannstöcke mechanisch

Twin vices mechanical Étaux mécaniques doubles

Ausführung:

- Doppelspannung mit 2 beweglichen und einer festen Spannbacke
- Horizontal und vertikal aufspannbar
- Stahlkörper allseitig geschliffen und gehärtet
- Eingebauter Niederzug
- Spannwiederholgenauigkeit $\leq 0,01$ mm
- Mittenspanngenauigkeit $\leq 0,01$ mm
- Betthöhe H: $\leq 0,01$ mm

Construction:

- Double-clamping via two mobile and one fixed jaw.
- Clamping positions: horizontal, and vertical
- The steel body is hardened and grinded all-round
- Integrated pull-down mechanism
- Repeating accuracy $\leq 0,01$ mm
- Clamping accuracy at the centre $\leq 0,01$ mm
- Bed height H: $\leq 0,01$ mm

Version:

- Double serrage avec 2 mors mobiles et un mors fixe
- Positions de serrage: horizontale, ou verticale
- Corps en acier trempé et rectifié de tous côtés
- Mécanisme de traction vers le bas intégré
- Répétition du serrage $\leq 0,01$ mm
- Précision de serrage du centre $\leq 0,01$ mm
- Hauteur du socle H: $\leq 0,01$ mm

Lieferumfang:

- Bedienungsanleitung
- Incl. Spannschlüssel
- 4 Stück Spannpratzen
- 4 Stück T-Nutensteine 18mm
- Messprotokoll

Delivery:

- Instructions for use
- Wrench
- 4 pcs. vice clamps
- 4 pcs. T-nuts 18mm
- Test certificate

Livraison avec:

- Mode d'emploi
- Clé de serrage
- 4 Mors de serrage
- 4 Tasseaux pour rainures en T 18mm
- Protocole de mesure

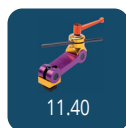
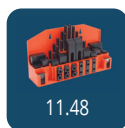
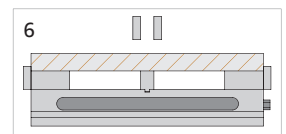
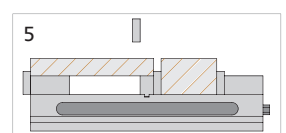
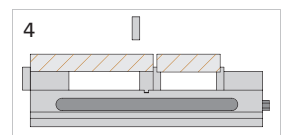
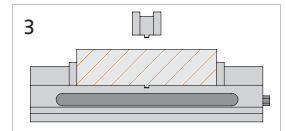
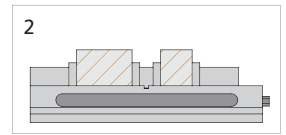
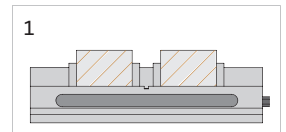
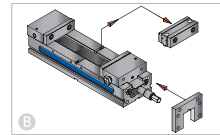
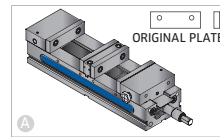
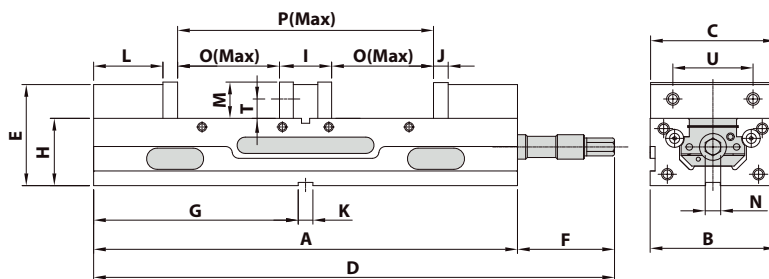
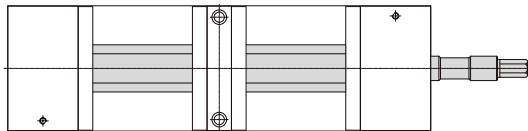

11

Bestell-Nr. Order no. Référence	Typ	A	B	C	D	E	F	G	H	I	J	K	L	M	N	O	P	T	U	kg	EUR
KS09010	TLD-40	405	104	102	459	96,5	54	27,5	63,50	55	15	18	69	38	14	90	235	17,5	63,5	20	1.699,00
KS09020	TLD-60	520	154	152	536	124,05	16	33,0	82,55	66	18	18	86,5	44,5	19	125	316	316	98,4	52	1.878,00*

* zzgl. Speditionskosten | * extra shipping costs | * frais de port supplémentaires

Twin vices mechanical Étaux mécaniques doubles

Ausführung:

- Doppelspannung mit 2 beweglichen und einer festen Spannbacke
- Horizontal und vertikal aufspannbar
- Stahlkörper allseitig geschliffen und gehärtet
- Eingebauter Niederzug
- Spannweitenholgenauigkeit $\leq 0,01$ mm
- Mittenspanngenauigkeit $\leq 0,01$ mm
- Betthöhe H: $\leq 0,01$ mm

Construction:

- Double-clamping via two mobile and one fixed jaw
- Clamping positions: horizontal and vertical
- The steel body is hardened and grinded all-round
- Integrated pull-down mechanism
- Repeating accuracy $\leq 0,01$ mm
- Clamping accuracy at the centre $\leq 0,01$ mm
- Bed height H: $\leq 0,01$ mm

Version:

- Double serrage avec 2 mors mobiles et un mors fixe
- Positions de serrage: horizontale, ou verticale
- Corps en acier trempé et rectifié de tous côtés
- Mécanisme de traction vers le bas intégré
- Répétition du serrage $\leq 0,01$ mm
- Précision de serrage du centre $\leq 0,01$ mm
- Hauteur du socle H: $\leq 0,01$ mm

Lieferumfang:

- Bedienungsanleitung
- Incl. Spannschlüssel
- 4 Stück Spannpratzen
- 4 Stück T-Nutensteine 18mm
- Messprotokoll

Delivery:

- Instructions for use
- Wrench
- 4 pcs. vice clamps
- 4 pcs. T-nuts 18mm
- Test certificate

Livraison avec:

- Mode d'emploi
- Clé de serrage
- 4 Mors de serrage
- 4 Tasseaux pour rainures en T 18mm
- Protocole de mesure

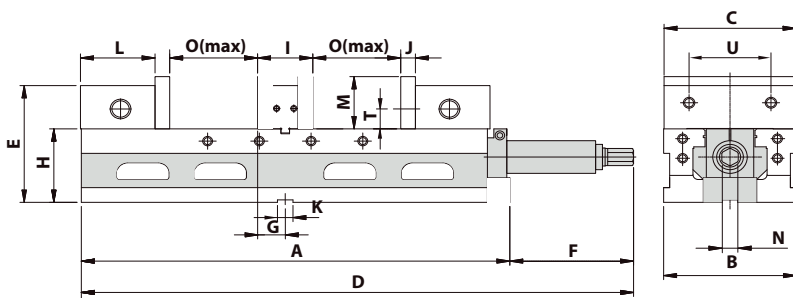
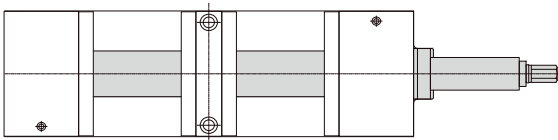
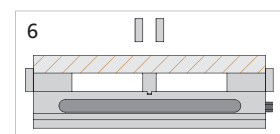
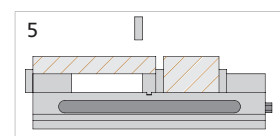
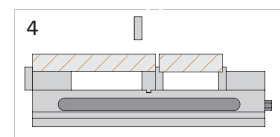
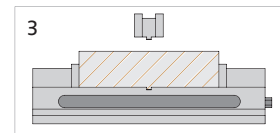
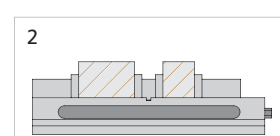
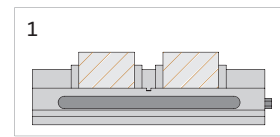
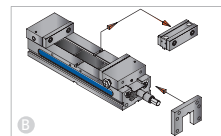
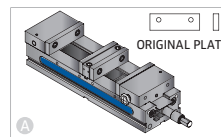
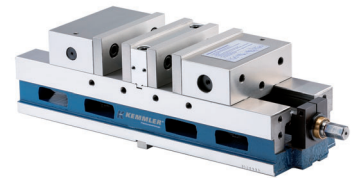
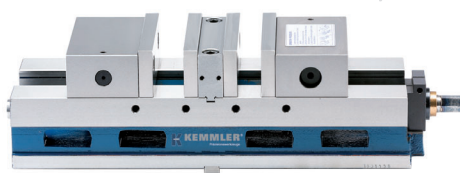
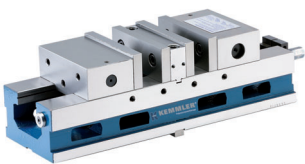

11.48



11.31



11.48

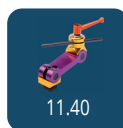

11.40

Bestell-Nr.

Order no.

Référence Typ

KS10010	ALD-60	A	B	C	D	E	F	G	H	I	J	K	L	M	N	O	T	U	kg	EUR
KS10010	ALD-60	497	154	152	610	143	113	32	90	64	17	18	86,5	58	19	34-102	32	95	63,5	2.007,00*

* zzgl. Speditionskosten | * extra shipping costs | * frais de port supplémentaires

K 5-Achs Maschinen-Schraubstöcke

5-Axis-Machine vices Étaux à 5-axes

Ausführung:

- Horizontal, vertikal oder seitlich aufspannbar
- Stahlkörper allseitig geschliffen und gehärtet
- Eingebauter Niederzug
- Betthöhe H: $\leq 0,01$ mm

Construction:

- Clamping positions: horizontal, vertical and lateral
- The steel body is hardened and grinded all-round
- Integrated pull-down mechanism
- Bed height H: $\leq 0,01$ mm

Version:

- Positions de serrage: horizontale, verticale ou latérale
- Corps en acier trempé et rectifié de tous côtés
- Mécanisme de traction vers le bas intégré
- Hauteur du socle H: $\leq 0,01$ mm

Lieferumfang:

- Bedienungsanleitung
- Incl. Spannschlüssel
- 4 Stück Spannpratzen
- 4 Stück T-Nutensteine 18mm
- Messprotokoll

Delivery:

- Instructions for use
- Wrench
- 4 pcs. vice clamps
- 4 pcs. T-nuts 18mm
- Test certificate

Livraison avec:

- Mode d'emploi
- Clé de serrage
- 4 Mors de serrage
- 4 Tasseaux pour rainures en T 18mm
- Protocole de mesure

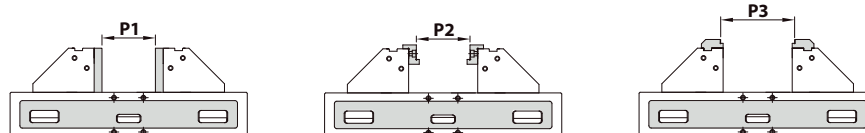
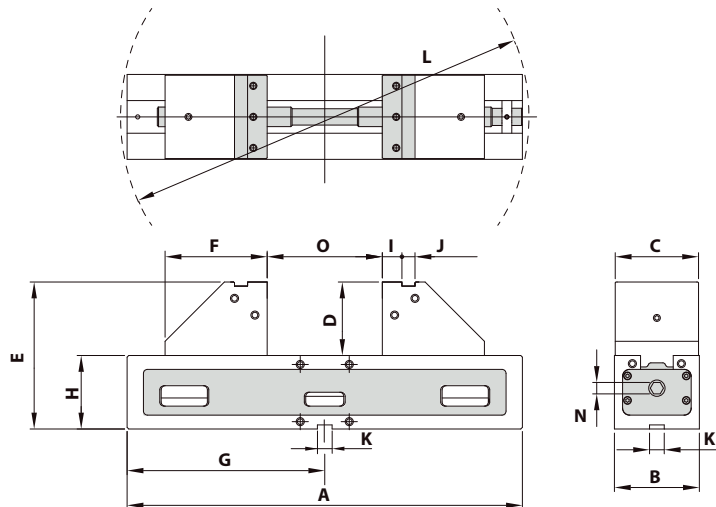

Bestell-Nr. Order no. Référence	Typ	A	B	C	D	E	F	G	H	I	J	K	L	N	O	P1	P2	P3	KN	kg	EUR
KS20100	ALT-100M	324	104	102	90	180	125	162	90	24	16	18	350	14	0-74	0-44	12-44	10-84	20	20	3.932,00
KS20101	ALT-100L	484	104	102	90	180	125	242	90	24	16	18	500	14	10-232	0-200	12-200	10-210	20	30	5.108,00*

* zzgl. Speditionskosten | * extra shipping costs | * frais de port supplémentaires

mechanisch mit Spannkraftverstärker

5-Axis precision vice AEX 125G mechanical with mechanical booster

Étau de précision à 5 axes AEX 125G mécanique avec l'amplificateur de serrage

Ausführung:

- Mit mechanischem Spannkraftverstärker
- Spannkraft voreinstellbar durch Rillenmarkierung
- Eingebauter Niederzug
- Betthöhe H: $\leq 0,01$ mm

Lieferumfang:

- Bedienungsanleitung
- Incl. Spannschlüssel
- 4 Stück Spannpratzen
- 4 Stück T-Nutensteine 14mm
- Messprotokoll

Spannkraft:

KS20200 = 40 kN

Construction:

- With mechanical booster
- Clamping force preadjustable by graduation lines
- Integrated pull-down mechanism
- Bed height H: $\leq 0,01$ mm

Delivery:

- Instructions for use
- Wrench
- 4 pcs. vice clamps
- 4 pcs. T-nuts 14mm
- Test certificate

Clamping force:

KS20200 = 40 kN

Version:

- Avec l'amplificateur de serrage mécanique
- Force de serrage pré-réglable par le marquage des rainures
- Mécanisme de traction vers le bas intégré
- Hauteur du socle H: $\leq 0,01$ mm

Livraison avec:

- Mode d'emploi
- Clé de serrage
- 4 Mors de serrage
- 4 Tasseaux pour rainures en T 14mm
- Protocole de mesure

Force de serrage:

KS20200 = 40 kN

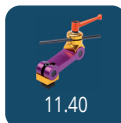
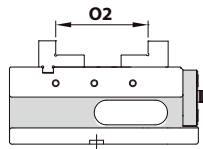
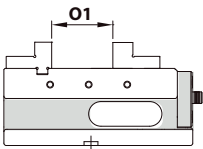
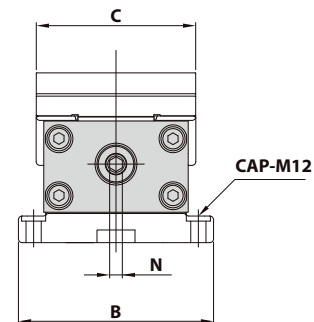
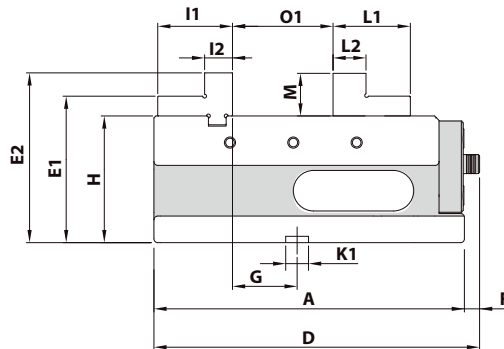
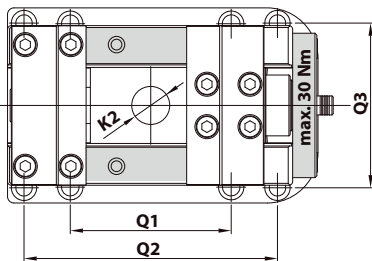

Lieferung mit Krallenbacken
Delivery with claw jaws
Livré avec mors à griffes

Bestell-Nr. Order no. Référence	Typ	A	B	C	D	E	E1	E2	F	G	H	I1	I2	K1	K2	L1	L2	M	N	O1	O2	Q1	Q2	Q3	kN	kg	EUR
KS20200	AEX-125G	245	154	126	257	34	116	134	12	51	100	59	22	18	∅30	61	26	34	10	100	72-139	127	200	130	40	20	2.184,00

K Mehrfachspannsystem 3-teilig

Multiple Clamping System 3-parts
Système de serrage multiple 3 pièces

Ausführung:

- Mit mechanischem Spannkraftverstärker
- Spannkraft voreinstellbar durch Rillenmarkierung
- Stahlkörper allseitig geschliffen und gehärtet
- Eingebauter Niederzug
- Betthöhe H: $\leq 0,01$ mm

Lieferumfang:

- Bedienungsanleitung
- Incl. Spannschlüssel
- 4 Stück Spannpratzen
- 4 Stück T-Nutensteine 18mm
- Messprotokoll

Spannkraft:

KS22020 = 50 kN

Construction:

- With mechanical booster
- Clamping force preadjustable by graduation lines
- The steel body is hardened and grinded all-round
- Integrated pull-down mechanism
- Bed height H: $\leq 0,01$ mm

Delivery:

- Instructions for use
- Wrench
- 4 pcs. vice clamps
- 4 pcs. T-nuts 18mm
- Test certificate

Clamping force:

KS22020 = 50 kN

Version:

- Avec l'amplificateur de serrage mécanique
- Force de serrage pré-réglable par le marquage des rainures
- Corps en acier trempé et rectifié de tous côtés
- Mécanisme de traction vers le bas intégré
- Hauteur du socle H: $\leq 0,01$ mm

Livraison avec:

- Mode d'emploi
- Clé de serrage
- 4 Mors de serrage
- 4 Tasseaux pour rainures en T 18mm
- Protocole de mesure

Force de serrage:

KS22020 = 50 kN

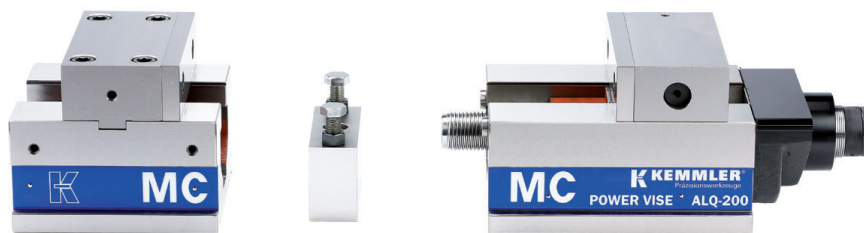
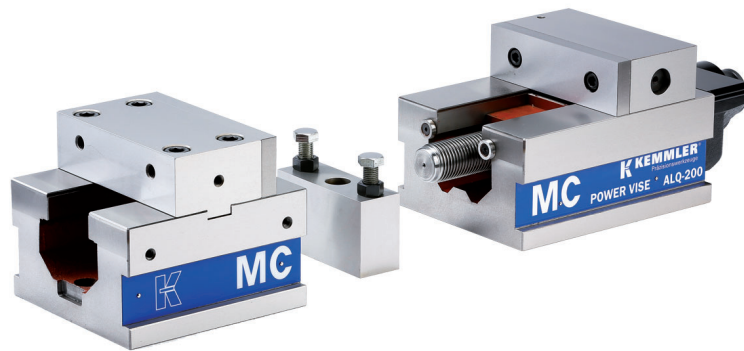

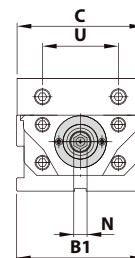
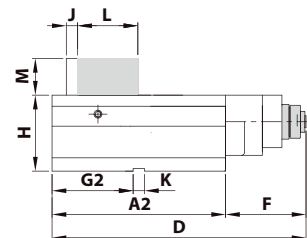
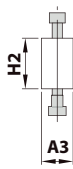
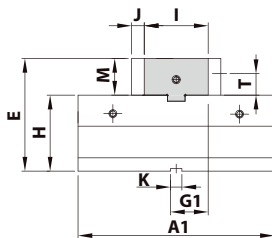
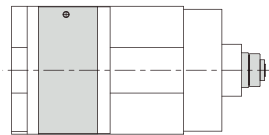
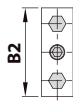
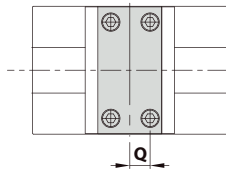
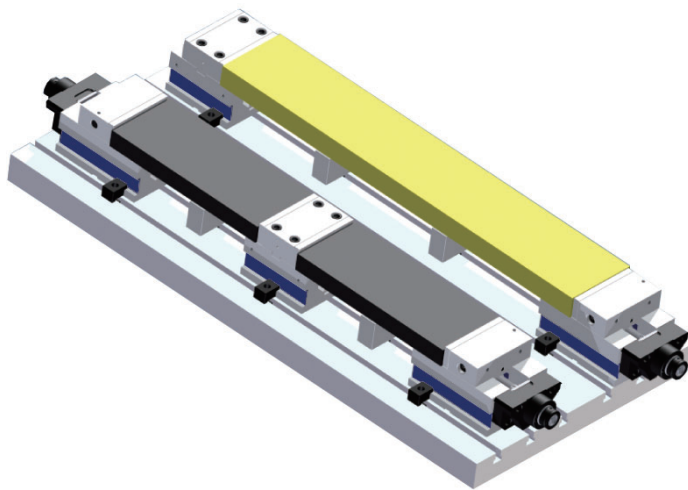
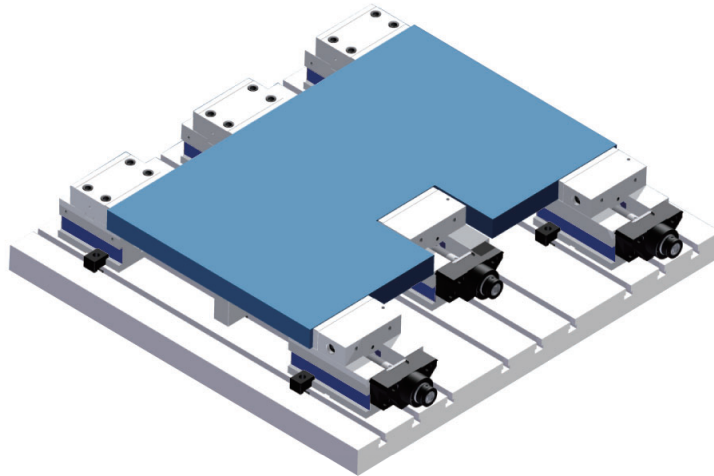

Bestell-Nr. Order no. Référence	Typ	A1	A2	A3	B1	B2	C	D	E	F	G1	G2	H	I	J	K	L	M	N	Q	T	U	KN	kg	EUR
KS22020	AOM-200	210	270	50	202	140	199,5	398	178	128	59,5	126	120	101	18	18	95	58	19	31	29	120	50	95	2.572,00*

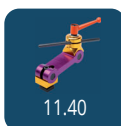
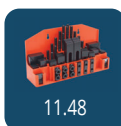

* zzgl. Speditionskosten
* extra shipping costs
* frais de port supplémentaires

K Präzisionsschraubstöcke mechanisch

Precision vices mechanical Étaux de précision mécanique

Ausführung:

- Horizontal, vertikal oder seitlich aufspannbar
- Stahlkörper allseitig geschliffen und gehärtet
- Eingebauter Niederzug
- Betthöhe H: $\leq 0,01$ mm

Construction:

- *Clamping positions: horizontal, vertical and lateral*
- *The steel body is hardened and grinded all-round*
- *Integrated pull-down mechanism*
- *Bed height H: $\leq 0,01$ mm*

Version:

- Positions de serrage: horizontale, verticale ou latérale
- Corps en acier trempé et rectifié de tous côtés
- Mécanisme de traction vers le bas intégré
- Hauteur du socle H: $\leq 0,01$ mm

Lieferumfang:

- Bedienungsanleitung
- Incl. Spannschlüssel
- 4 Stück Spannpratzen
- 4 Stück T-Nutensteine 18mm
- Messprotokoll

Delivery:

- *Instructions for use*
- *Wrench*
- 4 pcs. vice clamps
- 4 pcs. T-nuts 18mm
- *Test certificate*

Livraison avec:

- Mode d'emploi
- Clé de serrage
- 4 Mors de serrage
- 4 Tasseaux pour rainures en T 18mm
- Protocole de mesure

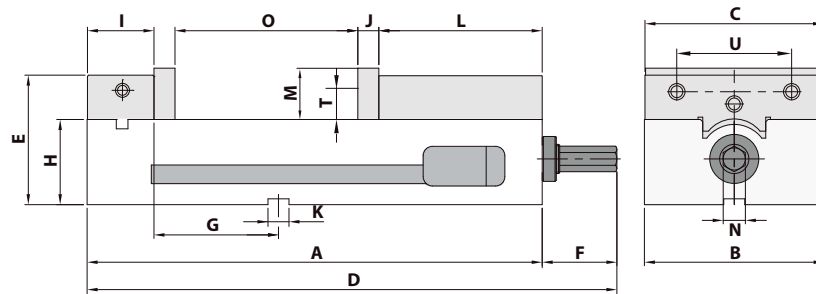

11

Bestell-Nr. Order no. Référence	Typ	A	B	C	D	E	F	G	H	I	J	K	L	M	N	O	T	U	kg	EUR
KS12010	AMC-40	330	105	102	372	100	42	91,6	68	46,8	21	18	106	40,0	14	125	17,5	63,5	21,0	722,00
KS12020	AMC-60	390	154	151	455	111	65	106,7	73	57,0	18	18	140	44,5	19	148	23,8	98,4	36,5	838,00*

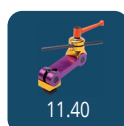
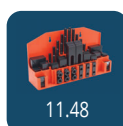
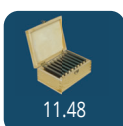

* zzgl. Speditionskosten
* extra shipping costs
* frais de port supplémentaires

Precision vices mechanical Étaux de précision mécanique

Ausführung:

- Horizontal und vertikal aufspannbar
- Stahlkörper geschliffen und gehärtet
- Eingebauter Niederzug
- Betthöhe H: $\leq 0,01$ mm

Construction:

- *Clamping positions: horizontal and vertical*
- *The steel body is hardened and grinded*
- *Integrated pull-down mechanism*
- *Bed height H: $\leq 0,01$ mm*

Version:

- Positions de serrage: horizontale ou verticale
- Corps en acier trempé et rectifié de tous côtés
- Mécanisme de traction vers le bas intégré
- Hauteur du socle H: $\leq 0,01$ mm

Lieferumfang:

- Bedienungsanleitung
- Incl. Spannschlüssel
- Messprotokoll

Delivery:

- *Instructions for use*
- *Wrench*
- *Test certificate*

Livraison avec:

- Mode d'emploi
- Clé de serrage
- Protocole de mesure

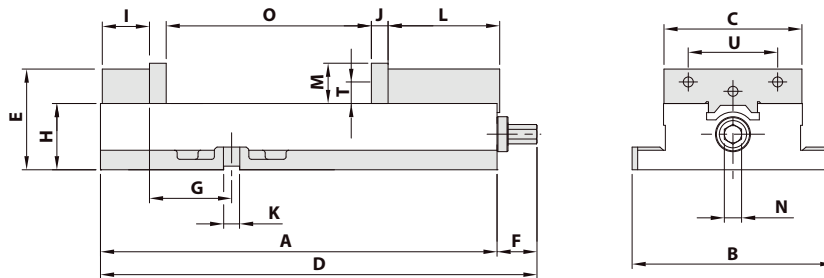
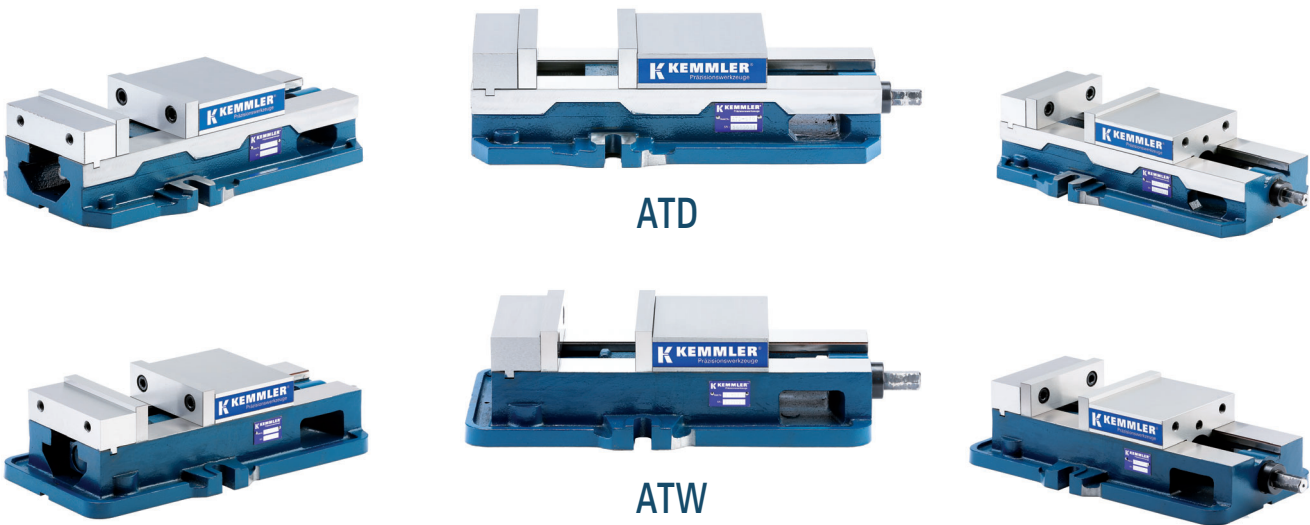

Bestell-Nr. Order no. Référence Typ	A	B	C	D	E	F	G	H	I	J	K	L	M	N	O	T	U	kg	EUR
KS11010 ATD-460	312,5	166	102	361	85,65	40	71	57,15	35,1	15	12	102	35,0	14	153	17,5	63,5	18	503,00
KS11020 ATD-570	368	194	127,0	404	97,00	36	85	63,5	40,5	17	16	120	38,1	16	178	20,6	79,4	25	567,00
KS11030 ATW-675	432	235	151	476	111,025	44	108	73,02	52	18	18	123	44,5	19	192	23,8	98,4	36	632,00*
KS11040 ATW-689	437	222	151	481	111,025	44	90,5	73,025	52	18	18	123	44,5	19	226	23,8	98,4	36	722,00*
KS11050 ATW-810	555	295	206	615	134,074	60	125,7	84,074	58	24,2	20	157	56,0	19	265	32,0	120	68	1.403,00*

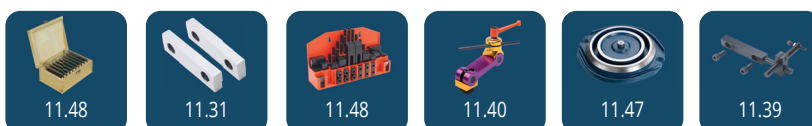

* zzgl. Speditionskosten
* extra shipping costs
* frais de port supplémentaires

K Präzisionsschraubstöcke mechanisch

Precision vices mechanical Étaux de précision mécanique

Ausführung:

- Horizontal, vertikal oder seitlich aufspannbar
- Stahlkörper allseitig geschliffen und gehärtet
- Eingebauter Niederzug
- Betthöhe H: $\leq 0,01$ mm

Construction:

- Clamping positions: horizontal, vertical and lateral
- The steel body is hardened and grinded all-round
- Integrated pull-down mechanism
- Bed height H: $\leq 0,01$ mm

Version:

- Positions de serrage: horizontale, verticale ou latérale
- Corps en acier trempé et rectifié de tous côtés
- Mécanisme de traction vers le bas intégré
- Hauteur du socle H: $\leq 0,01$ mm

Lieferumfang:

- Bedienungsanleitung
- Incl. Spannschlüssel
- 4 Stück Spannpratzen
- 4 Stück T-Nutensteine 18mm
- Messprotokoll

Delivery:

- Instructions for use
- Wrench
- 4 pcs. vice clamps
- 4 pcs. T-nuts 18mm
- Test certificate

Livraison avec:

- Mode d'emploi
- Clé de serrage
- 4 Mors de serrage
- 4 Tasseaux pour rainures en T 18mm
- Protocole de mesure

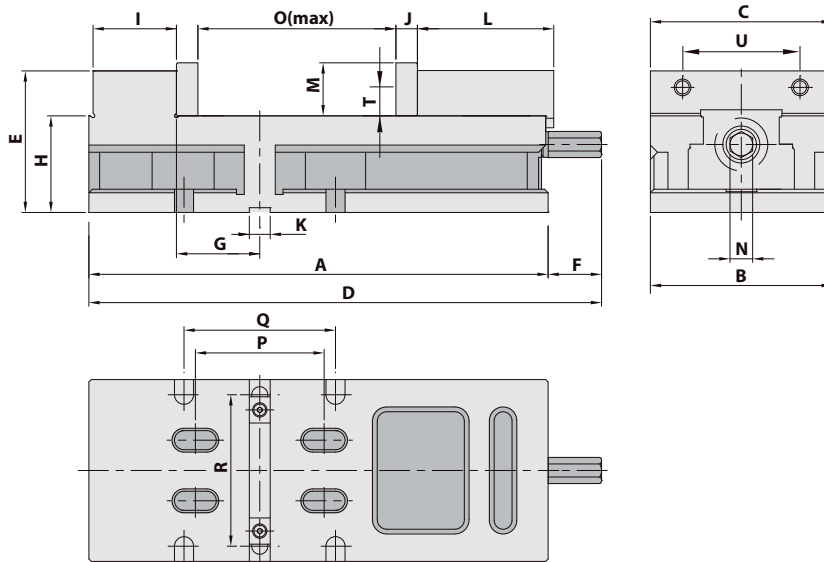

11

Bestell-Nr. Order no. Référence	Typ	A	B	C	D	E	F	G	H	I	J	K	L	M	N	O	P	Q	R	T	U	kg	EUR
KS13010	MG-60G	385	152,45	151	431,8	118,7	46,8	69,85	81	69,9	18	18	114,3	44,5	19	163	107,95	127	127	23,8	98,4	31	1.081,00*

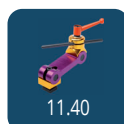

* zzgl. Speditionskosten
* extra shipping costs
* frais de port supplémentaires

5th AXIS[®]

Workholding Evolved.



Mehr Produkte und Informationen finden Sie in unserem 5th Axis Hauptkatalog.
Please check our 5th Axis catalogue for more products and detailed information.
 Vous trouverez plus de produits et d'informations dans notre catalogue principal 5th Axis.

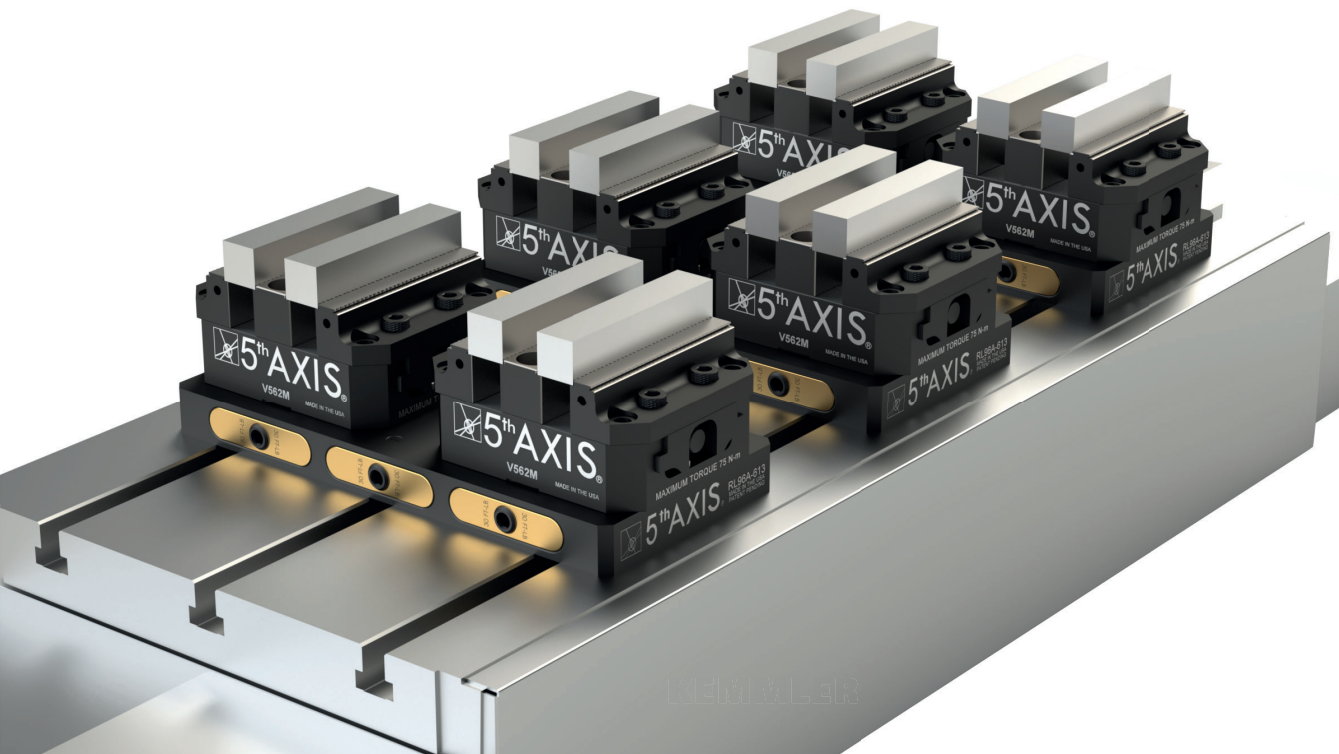



Präzisionsschraubstöcke mechanisch mit Spannkraftverstärker

Precision vices mechanical with mechanical booster
Étaux de précision mécanique avec répéteur de la tension du ressort

Ausführung:

- Mit mechanischem Spannkraftverstärker
- Spannkraft voreinstellbar durch Rillenmarkierung
- Horizontal und vertikal aufspannbar
- Führungen geschliffen und gehärtet
- Betthöhe H: ≤ 0,01 mm

Lieferumfang:

- Bedienungsanleitung
- Incl. Spannschlüssel
- Messprotokoll

Spannkraft:

KS06010 = 40 kN
KS06020 = 50 kN
KS06030 = 60 kN

Construction:

- With mechanical booster
- Clamping force preadjustable by graduation lines
- Clamping positions: horizontal and vertical
- Slides hardened and grinded
- Bed height H: ≤ 0,01 mm

Delivery:

- Instructions for use
- Wrench
- Test certificate

Clamping force:

KS06010 = 40 kN
KS06020 = 50 kN
KS06030 = 60 kN

Version:

- Avec l'amplificateur de serrage mécanique
- Force de serrage pré-réglable par le marquage des rainures
- Positions de serrage: horizontale ou verticale
- Glissières trempées et rectifiées
- Hauteur du socle H: ≤ 0,01 mm

Livraison avec:

- Mode d'emploi
- Clé de serrage
- Protocole de mesure

Force de serrage:

KS06010 = 40 kN
KS06020 = 50 kN
KS06030 = 60 kN

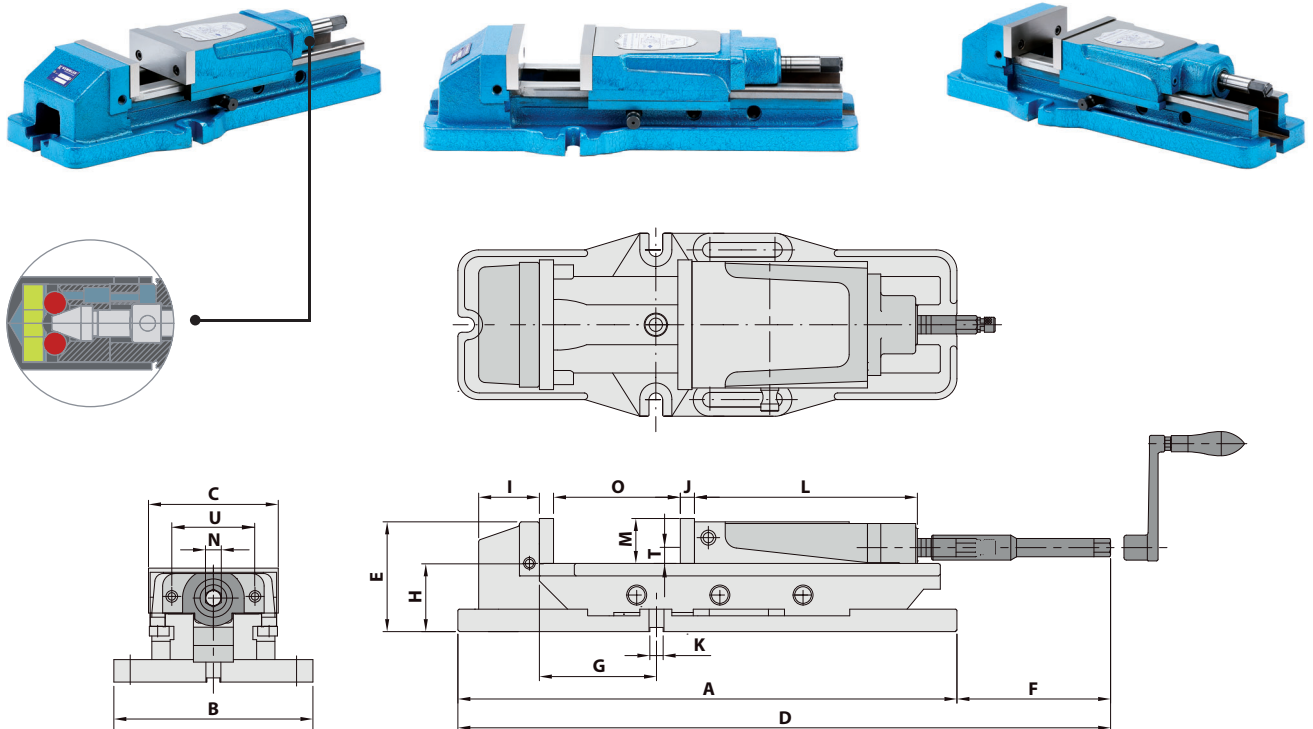

11

Mit patentiertem mechanischem Spannkraftverstärker:

- kein Ölverlust
- genaue Wiederholbarkeit der Spannkraft
- keine Veränderung der Spannkraft
- keine Vibrationen während der Bearbeitung
- lange Lebensdauer

With patented mechanical booster:

- no loss of oil
- exact repeatability of the clamping force
- constant clamping force
- no vibrations during the operation
- long life

Avec l'amplificateur de la force de serrage mécanique patenté:

- pas de perte d'huile
- la répétition précise de la force de serrage
- pas de changement de la force de serrage
- pas de vibrations pendant l'usage
- longue durée de vie

Bestell-Nr. Order no. Référence	Typ	A	B	C	D	E	F	G	H	I	J	K	L	M	N	O	P	T	U	kN	kg	EUR
KS06010	MP-50A	538	203	130	670	117	132	82	72	82	15	16	175	46	19	220	60	16	85	40	38	1.081,00*
KS06020	MP-60A	608	220	154	800	132	180	140	82	74	17	16	208	54	19	300	80	18	100	50	58	1.146,00*
KS06030	MP-80A	700	285	206	900	160	200	118	100	113	21	18	245	62	19	300	100	24,5	120	60	104	2.252,00*

* zzgl. Speditionskosten | * extra shipping costs | * frais de port supplémentaires

Precision vices hydraulic Étaux de précision hydraulique

Ausführung:

- Spannkraft voreinstellbar durch Rillenmarkierung
- Horizontal und vertikal aufspannbar
- Führungen geschliffen und gehärtet
- Betthöhe H: $\leq 0,01$ mm

Construction:

- Clamping force preadjustable by graduation lines
- Clamping positions: horizontal and vertical
- Slides hardened and grinded
- Bed height H: $\leq 0,01$ mm

Version:

- Force de serrage pré-réglable par le marquage des rainures
- Positions de serrage: horizontale, ou verticale
- Glissières trempées et rectifiées
- Hauteur du socle H: $\leq 0,01$ mm

Lieferumfang:

- Bedienungsanleitung
- Incl. Spannschlüssel
- Messprotokoll

Delivery:

- Instructions for use
- Wrench
- Test certificate

Livraison avec:

- Mode d'emploi
- Clé de serrage
- Protocole de mesure

Spannkraft:

KS07010 = 25 kN
KS07020 = 35 kN
KS07030 = 44 kN
KS07040 = 66 kN

Clamping force:

KS07010 = 25 kN
KS07020 = 35 kN
KS07030 = 44 kN
KS07040 = 66 kN

Force de serrage:

KS07010 = 25 kN
KS07020 = 35 kN
KS07030 = 44 kN
KS07040 = 66 kN

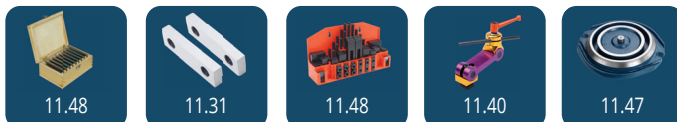
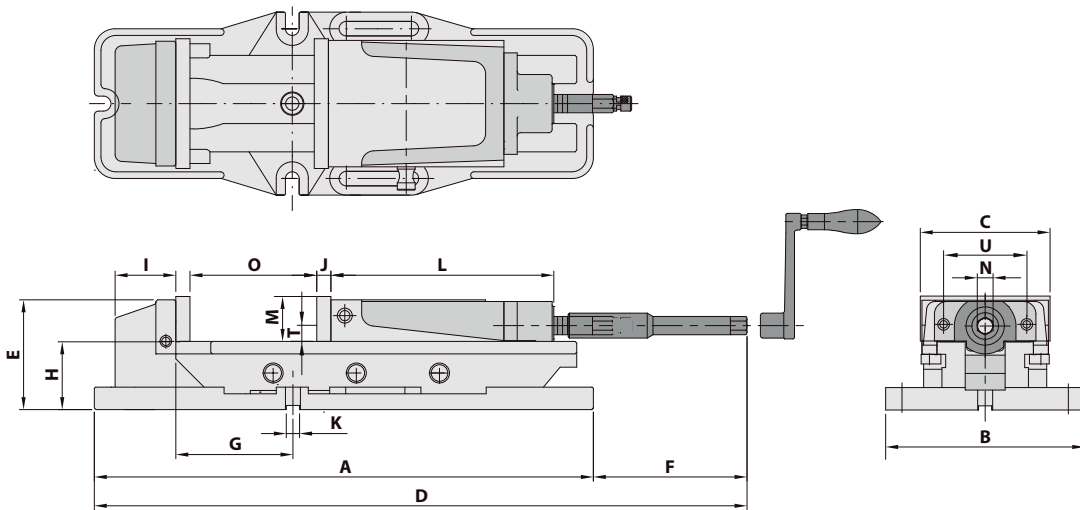
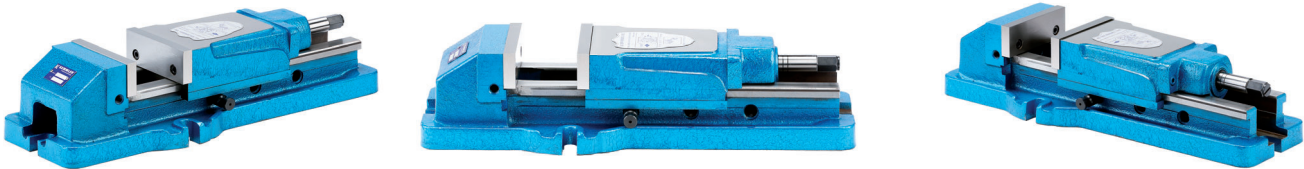

Bestell-Nr. Order no. Référence	Typ	A	B	C	D	E	F	G	H	I	J	K	L	M	N	O	P	T	U	kN	kg	EUR
KS07020	HP-50A	538	203	130	670	117	132	82	72	82	15	16	175	46	19	220	-	16	85	35	37	1.081,00*
KS07030	HP-60A	608	220	154	800	132	180	140	82	74	17	16	208	54	19	300	-	18	100	44	58	1.147,00*
KS07040	HP-80A	700	285	206	900	160	200	118	100	113	21	18	245	62	19	300	-	24,5	120	66	104	2.238,00*

K Präzisionsschraubstöcke mechanisch

Precision vices mechanical Étaux de précision mécanique

Ausführung:

- Horizontal, vertikal oder seitlich aufspannbar
- Stahlkörper allseitig geschliffen und gehärtet
- Betthöhe H: $\leq 0,01$ mm

Construction:

- Clamping positions: horizontal, vertical and lateral
- The steel body is hardened and grinded all-round
- Bed height H: $\leq 0,01$ mm

Version:

- Positions de serrage: horizontale, verticale ou latérale
- Corps en acier trempé et rectifié de tous côtés
- Hauteur du socle H: $\leq 0,01$ mm

Lieferumfang:

- Bedienungsanleitung
- Incl. Spannschlüssel
- 4 Stück Spannpratzen
- Zentrier-Nutensteine (Paar)

Delivery:

- Instructions for use
- Wrench
- 4 pcs. vice clamps
- Centering nut (Pair)

Livraison avec:

- Mode d'emploi
- Clé de serrage
- 4 Mors de serrage
- Ecrus à rainure de centrage (Paire)

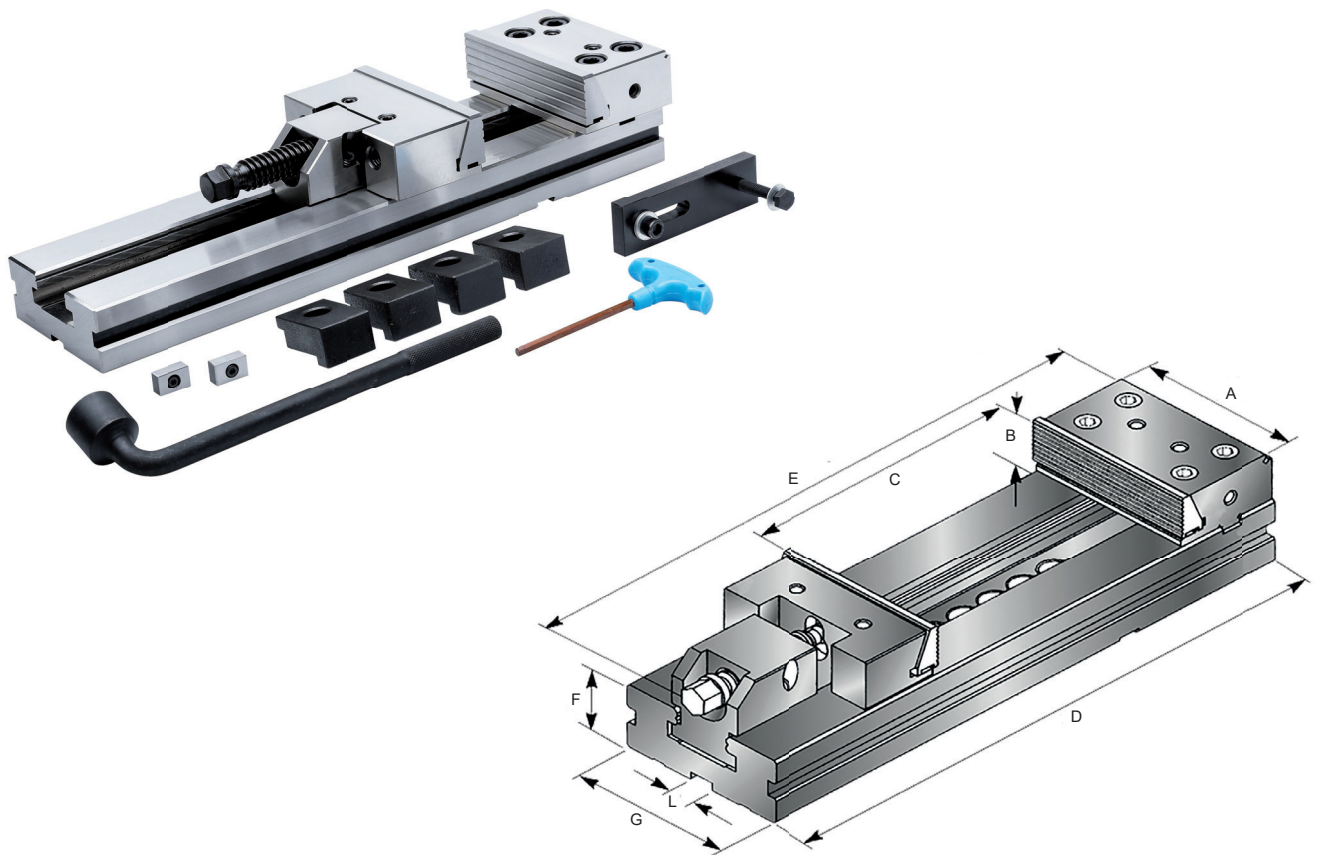

11.311.29
11

Bestell-Nr. Order no. Référence	Typ	A	B	C	D	E	F	G	L	kg	EUR
KS30125	ATI-125	125	40	150	345	410	40	95	16	13	729,00*
KS30150	ATI-150	150	50	300	520	600	50	125	16	29	1.145,00*
KS30175	ATI-175	175	60	300	555	630	58	145	16	42	1.166,00*
KS30200	ATI-200	200	65	400	695	780	70	170	16	74	1.961,00*

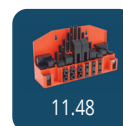
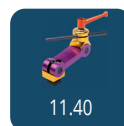

* zzgl. Speditionskosten
* extra shipping costs
* frais de port supplémentaires

Drehplatte ATI
Swivel base ATI
Plateau tournant ATI

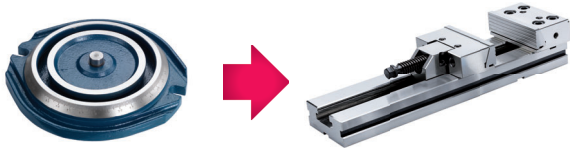

Bestell-Nr. Order no. Référence	Typ	EUR
Z.KS.30125	ATI-125	331,00
Z.KS.30150	ATI-150	378,00
Z.KS.30175	ATI-175	426,00
Z.KS.30200	ATI-200	473,00

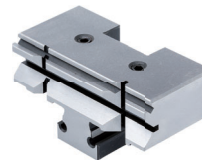

Prismenbacken
Prismatic jaws
Mors prismatiques

Bestell-Nr. Order no. Référence	Typ	EUR
Z.KS.PR.30125	ATI-125	147,00
Z.KS.PR.30150	ATI-150	189,00
Z.KS.PR.30175	ATI-175	221,00
Z.KS.PR.30200	ATI-200	305,00



Niederzugbacken
Hold down jaws
Mors de traction vers le bas

Bestell-Nr. Order no. Référence	Typ	EUR
Z.KS.NZ.30125	ATI-125	147,00
Z.KS.NZ.30150	ATI-150	200,00
Z.KS.NZ.30175	ATI-175	252,00
Z.KS.NZ.30200	ATI-200	305,00



Ersatzbacken
Jaws
Mors d'échange

Bestell-Nr. Order no. Référence	Typ	EUR
Z.KS.SA.30125	ATI-125	89,00
Z.KS.SA.30150	ATI-150	95,00
Z.KS.SA.30175	ATI-175	111,00
Z.KS.SA.30200	ATI-200	136,00



Weiche Backen
Soft jaws
Mâchoires souples

Bestell-Nr. Order no. Référence	Typ	EUR
Z.KS.WB.30125	ATI-125	72,00
Z.KS.WB.30150	ATI-150	84,00
Z.KS.WB.30175	ATI-175	102,00
Z.KS.WB.30200	ATI-200	150,00



Zubehör für ATI Schraubstöcke

Accessories for ATI vices
Accessoires pour étaux ATI

Kugel für ATI Schraubstock

Ball for ATI vice
Boule pour étau ATI



Bestell-Nr. Order no. Référence	Typ	EUR
ERS.KS30125.01	ATI-125	5,00
ERS.KS30150.01	ATI-150	5,00
ERS.KS30175.01	ATI-175	5,00
ERS.KS30200.01	ATI-200	6,00

Gewindespindel für ATI Schraubstock

Lead screw for ATI vice
Tige filetée pour étau ATI



Bestell-Nr. Order no. Référence	Typ	EUR
ERS.KS30125.02	ATI-125	18,00
ERS.KS30150.02	ATI-150	18,00
ERS.KS30175.02	ATI-175	18,00
ERS.KS30200.02	ATI-200	30,00

Spannelement komplett für ATI Schraubstock

Complete clamping element for ATI vice
Élément de serrage complet pour étau ATI

11



Bestell-Nr. Order no. Référence	Typ	EUR
ERS.KS30125.03	ATI-125	60,00
ERS.KS30150.03	ATI-150	66,00
ERS.KS30175.03	ATI-175	85,00
ERS.KS30200.03	ATI-200	120,00

Accessories for ATI vices
Accessoires pour étaux ATI

Sicherungsschraube für ATI Schraubstock
Locking screw for ATI vice
Vis de sécurité pour étau ATI



Bestell-Nr. Order no. Référence	Typ	EUR
ERS.KS30125.04	ATI-125	4,00
ERS.KS30150.04	ATI-150	4,00
ERS.KS30175.04	ATI-175	4,00
ERS.KS30200.04	ATI-200	5,00

Spannpratzensatz 4-teilig für ATI Schraubstock
Clamping set 4-parts for ATI vice
Set de sabots de serrage 4 pieces pour étau ATI



Bestell-Nr. Order no. Référence	Typ	EUR
ERS.KS30125.21	ATI-125	22,00
ERS.KS30150.21	ATI-150	22,00
ERS.KS30175.21	ATI-175	22,00
ERS.KS30200.21	ATI-200	35,00

Zentriernutensteine für ATI Schraubstock (Paar)
Centering nut for ATI vice (Pair)
Coulisseaux à centrer pour étau pour étau ATI (Paire)

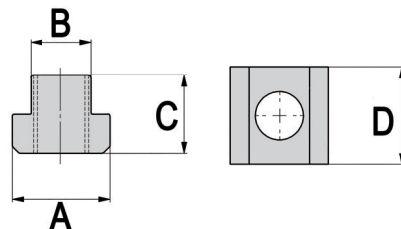

Bestell-Nr. Order no. Référence	A	B	C	D	EUR
ERS.KS30.22.1612	12	16	10	25	12,00
ERS.KS30.22.1614	14	16	10	25	12,00
ERS.KS30.22.1616	16	16	10	25	12,00
ERS.KS30.22.1618	18	16	10	25	12,00
ERS.KS30.22.1620	20	16	10	25	12,00
ERS.KS30.22.1622	22	16	10	25	14,00
ERS.KS30.22.1624	24	16	10	25	14,00



Schleif- und Kontrollschraubstöcke mit Gewindespindel

Grinding and inspection vices with threaded spindle
Étaux de rectification et de contrôle avec broche filetée

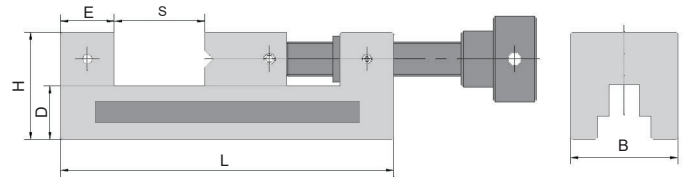
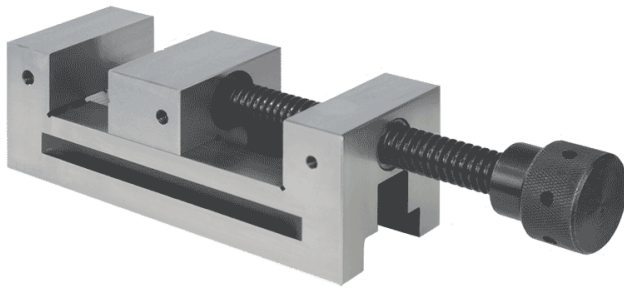

Bestell-Nr. Order no. Référence	B	H	E	D	S _{max}	L	kg	EUR
90.11.050	50	50	25	25	65	155	3	168,00
90.11.073	73	74	32	39	100	210	5	231,00
90.11.100	100	95	38	50	125	260	13	305,00

Schleif- und Kontrollschraubstöcke mit Schnellverstellung

Grinding and inspection vices with quick adjustment
Étaux de contrôle et de rectification à réglage rapide

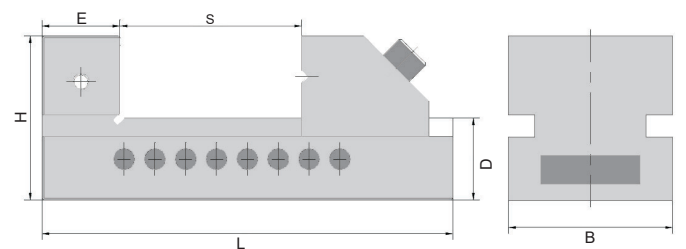
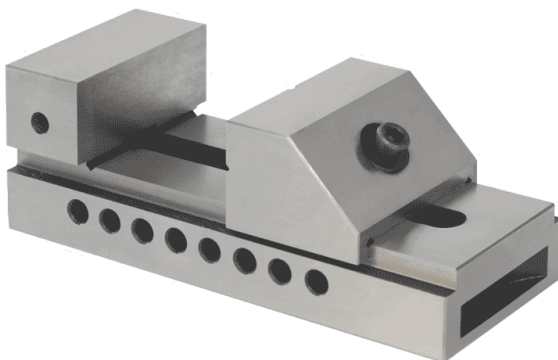

11

Bestell-Nr. Order no. Référence	B	H	E	D	S _{max}	L	kg	EUR
90.12.050	50	50	30	25	65	140	2	116,00
90.12.073	73	67	35	32	100	190	5	147,00
90.12.100	100	90	47	45	125	245	11	305,00

Universal, grinding and inspection vices
Étaux de contrôle et de rectification universel

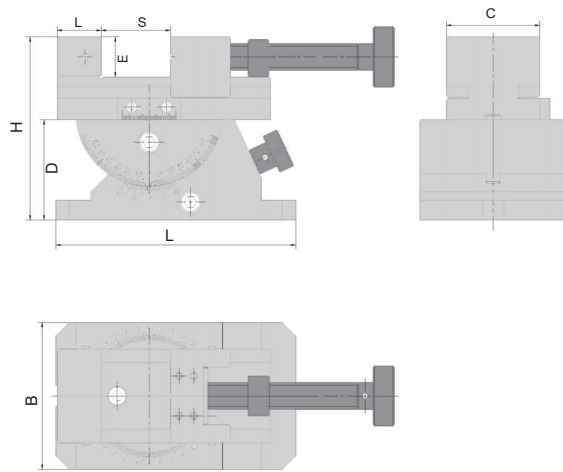
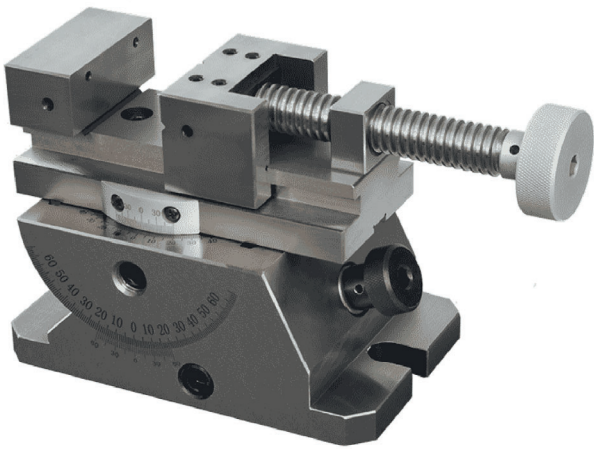

Bestell-Nr. Order no. Référence	B	H	D	E	C	S _{max}	L	kg	EUR
90.17.080	110	137	75	30	70	80	180	12	945,00

Bohrmaschinenschraubstöcke, mechanisch

Vices for drilling machines, mechanical
Étaux pour machines à percer, mécanique

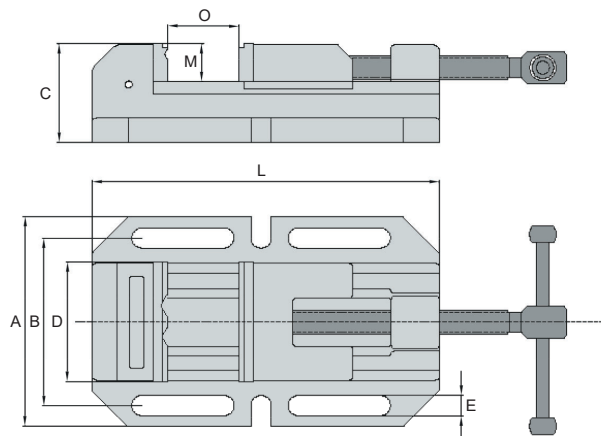

Bestell-Nr. Order no. Référence	Ausführung Version Version	A	B	C	D	E	L	O	M	kg	EUR
KS4080	MWM-80	141	111	50	80	11	152	70	22,5	2,3	50,00
KS4100	MWM-100	165	133,5	60	100	13,5	190	100	28,5	2,9	80,00
KS4150	MWM-150	220	182,5	70	150	15,5	250	150	28,5	5,7	120,00
KS4200	MWM-200	265	222,5	89	200	17,5	310	190	45,5	11,5	190,00



Ersatzbacken-Paare

Pair of spare jaws
Paire de mors de rechange

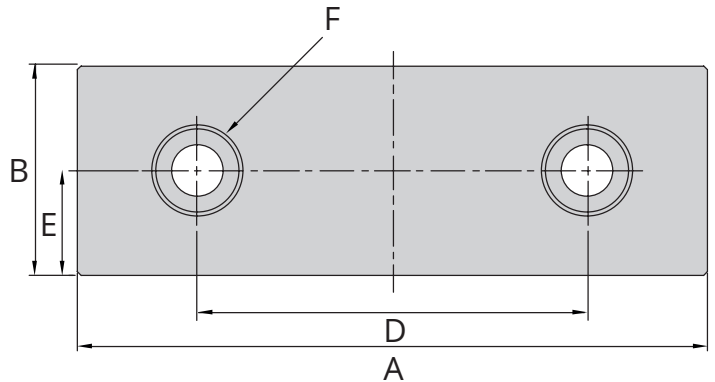
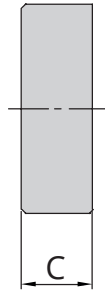

Bestell-Nr. Order no. Référence	Ausführung Version Version	A	B	C	D	E	F	EUR
Z.KS.SA.AT409	ATW-40 ATD-460	102	35	15	63,5	17,5	3/8 - 16 UNC	83,00
Z.KS.SA.AT509	ATW-50 ATD-570	126	38,1	17	79,4	20,6	7/16 - 14 UNC	100,00
Z.KS.SA.ATL609	ATW-675 ATW-689 MG-60 AMC-60 TLD-60 HLD60	151	44,1	18	98,4	23,8	1/2 - 13 UNC	103,00
Z.KS.SA.ATL809	ATW-810	206	56	24,2	120	32	5/8 - 11 UNC	213,00
Z.KS.SA.AMC409	AMC-40	102	40	21	63,5	17,5	3/8 - 16 UNC	74,00
Z.KS.SA.AMP5401	AMP-150	128	52	15	90	25	M10 x 1,5 P	155,00
Z.KS.SA.AMP6401	AMP-160 AMP-165	158	55	15	90	25	M10 x 1,5 P	135,00
Z.KS.SA.AMP7401	AMP-180	178	60	20	120	28	M12 x 1,75 P	150,00
Z.KS.SA.AMP8401	AMP-200 AMP-300	200	60	18	120	28	M12 x 1,75 P	160,00

Verwendung:
Für Teile mit empfindlichen Spannflächen

Application:
For parts with delicate clamping surfaces

Usage:
Pour les pièces avec la surface de serrage délicate

Werkstoff:
Stahl S50C | Gehärtet HRC 53 +/-2

Material:
Steel S50C | Hardened HRC 53 +/-2

Matériel:
Acier S50C | Trempé HRC 53 +/-2



Ersatzbacken ALT
Jaws ALT
Mors d'échange ALT

Bestell-Nr. Order no. Référence	Typ	EUR
Z.KS.ALT4401	ALT-100M/ALT-100L	221,00



Ersatzbacken ALT
Jaws ALT
Mors d'échange ALT

Bestell-Nr. Order no. Référence	Typ	EUR
Z.KS.ALT4402	ALT-100M/ALT-100L	315,00



Ersatzbacken ALT
Jaws ALT
Mors d'échange ALT

Bestell-Nr. Order no. Référence	Typ	EUR
Z.KS.ALT4403	ALT-100M/ALT-100L	300,00



Ersatzbacken ALT
Jaws ALT
Mors d'échange ALT

Bestell-Nr. Order no. Référence	Typ	EUR
Z.KS.ALT4404	ALT-100M/ALT-100L	237,00

11

Pair of spare jaws
Paire de mors de rechange

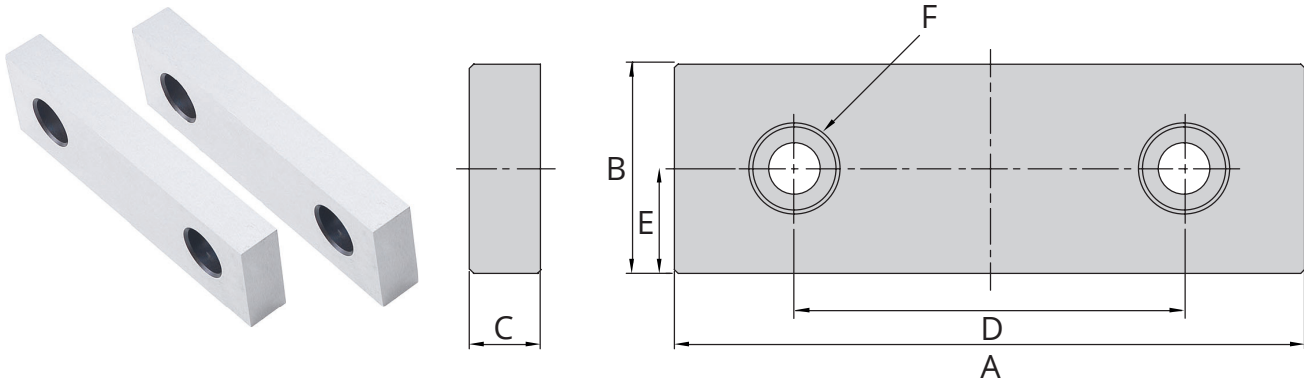

Bestell-Nr. Order no. Référence	Ausführung Version Version	A	B	C	D	E	F	EUR	
Z.KS.SA.AVQ4401	AVQ-100 AVL-100	102	45	15	58	22,5	M8x 1,25 P	87,00	
Z.KS.SA.AVQ5401	AVQ-125 AVL-125	124,7	53	15	60	26,5	M10 x 1,5 P	100,00	
Z.KS.SA.AVQ6401	AVQ-160 AVL-160 ALQ-160	159,2	53	18	98,4	26,5	M12 x 1,75 P	140,00	
Z.KS.SA.AVQ8401	AVQ-200 AVL-200 ALQ-200 AOM-200	199,5	58	18	120	29	M12 x 1,75 P	216,00	
Z.KS.SA.HP503	HP-50 MP-50	130	46	15	85	16	5/16 - 18 UNC	87,00	
Z.KS.SA.HP603	HP-60 MP-60	154	54	17	100	18	3/8 - 16 UNC	133,00	
Z.KS.SA.HP803	HP-80 MP-80	206	62	21	120	24,5	M10 x 1,5 P	223,00	
Z.KS.SA.AVC6401	AVC-160 AVM-160	160	58	15	90	25	M10 x 1,5 P	117,00	
Z.KS.SA.AVC8401	AVC-200 AVM-200	200	63	18	120	28	M12 x 1,75 P	137,00	
Z.KS.SA.AVK640201	AVK-160	160	60	15	85	26,5	M10 x 1,5 P	133,00	
Z.KS.SA.TLD4401	TLD-40	2 Paar 2 pair 2 paire	102	38	15	63,5	17,5	3/8 - 16 UNC	140,00
Z.KS.SA.ALD6401	ALD-60	2 Paar 2 pair 2 paire	152	58	17	95	32	M12 x 1,75 P	262,00

Verwendung:

Für Teile mit empfindlichen Spannflächen

Application:

For parts with delicate clamping surfaces

Usage:

Pour les pièces avec la surface de serrage délicate

Werkstoff:

Stahl S50C | Gehärtet HRC 53 +/-2

Material:

Steel S50C | Hardened HRC 53 +/-2

Matériel:

Acier S50C | Trempé HRC 53 +/-2

K Prismenbacken

Prismatic jaws
Mors prismatiques

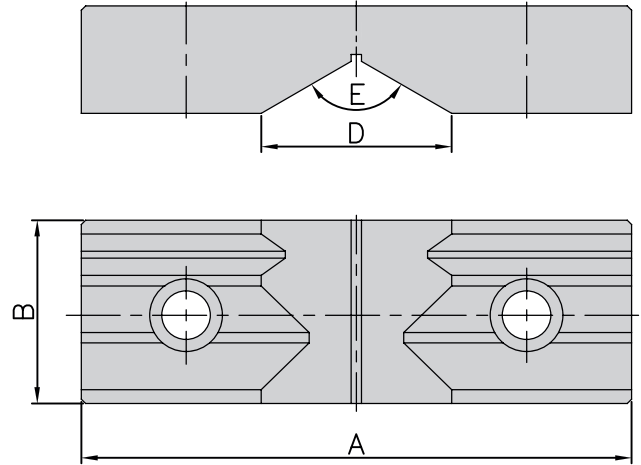
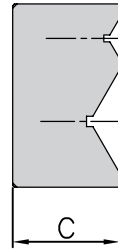

Bestell-Nr. Order no. Référence	Ausführung Version Version	A	B	C	D	E	EUR	
Z.KS.PR.AT409R	ATW-40 ATD-460	102	35	31	40	120°	133,00	
Z.KS.PR.AT509R	ATW-50 ATD-570	126	38,1	31	40	120°	140,00	
Z.KS.PR.AT609R	ATW-675 689 MG-60 AMC-60 TLD-60 HLD60	151	44,5	31	45	120°	160,00	
Z.KS.PR.AT809R	ATW-810	206	60	36	60	120°	233,00	
Z.KS.PR.AMC409R	AMC-40	102	40	30	40	120°	142,00	
Z.KS.PR.AVQ4407	AVQ-100 AVL-100	102	45	28	36,3	120°	140,00	
Z.KS.PR.AVQ5407	AVQ-125 AVL-125	124,7	53	31	50	120°	150,00	
Z.KS.PR.AVQ6407	AVQ-160 AVL-160 ALQ-160 AOM-160	159,2	53	31	55	120°	180,00	
Z.KS.PR.AVQ8407	AVQ-200 AVL-200 ALQ-200 AOM-200	200	56	31	55	120°	216,00	
Z.KS.PR.HP503R	HP-50 MP-50	130	46	31	45	120°	143,00	
Z.KS.PR.HP603R	HP-60 MP-60	154	54	31	55	120°	176,00	
Z.KS.PR.HP803R	HP-80 MP-80	206	62	36	60	120°	239,00	
Z.KS.PR.AVC6407	AVC-160 AVM-160	160	58	30	55	120°	183,00	
Z.KS.PR.AVC8407	AVC-200 AVM-200	200	63	36	70	120°	239,00	
Z.KS.PR.TLD4407	TLD-40	1 Paar 1 pair 1 paire	102	38	31	40	120°	246,00
Z.KS.PR.TLD6607	TLD-60	1 Paar 1 pair 1 paire	151	44,5	34	45	120°	320,00
Z.KS.PR.ALD6404	ALD-60	1 Paar 1 pair 1 paire	152	58	49	55	120°	385,00

11

Verwendung:

Zum Spannen von runden Bauteilen.
vertikal \varnothing 16 - 74 mm, horizontal \varnothing 12 - 40 mm

Application:

For clamping cylindrical components.
vertical \varnothing 16-74 mm, horizontal \varnothing 12-40 mm

Usage:

Pour le serrage de pièces rondes.
vertical \varnothing 16 - 74 mm, \varnothing horizontal 12 - 40 mm

Werkstoff:

Stahl S50C | Gehärtet HRC 53 +/-2

Material:

Steel S50C | Hardened HRC 53 +/-2

Matériel:

Acier S50C | Trempé HRC 53 +/-2

Step jaws (Pair)
Mors étagés (Paire)

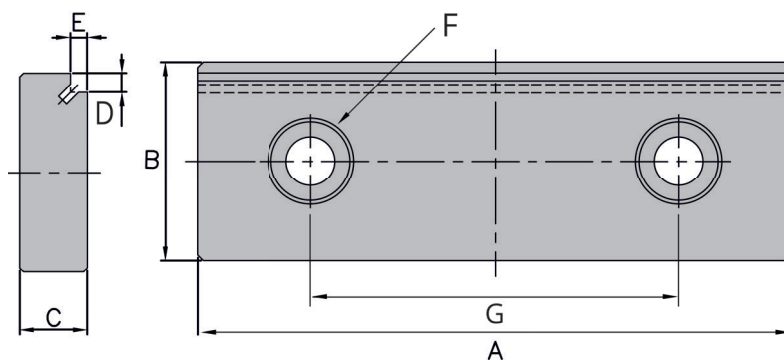

Bestell-Nr. Order no. Référence	Ausführung Version Version	A	B	C	D	E	F	G	EUR
Z.KS.ST.AT409L	ATW-40 ATD-460	102	35	15	4	3,5	3/8 - 16 UNC	63,5	103,00
Z.KS.ST.AT509L	ATW-50 ATD-570	126	38,1	17	4	3,5	7/16 - 14 UNC	79,4	110,00
Z.KS.ST.AT609L	ATW-675 ATW-689 MG-60 AMC-60 TLD-60 AMC-60 TLD-60 HLD-60	151	44,5	18	5	4,5	1/2 - 13 UNC	98,4	120,00
Z.KS.ST.AT809L	ATW-810	206	56	24,2	6	5,5	5/8 - 11 UNC	120	218,00
Z.KS.ST.AMC409L	AMC-40	102	40	21	4	3,5	3/8 - 16 UNC	63,5	107,00
Z.KS.ST.AVQ4404	AVQ-100 AVL-100	102	45	15	5	5	M8x 1,25 P	58	117,00
Z.KS.ST.AVQ5404	AVQ-125 AVL-125 ALQ-125	124,7	53	15	5	5	M10 x 1,5 P	60	133,00
Z.KS.ST.AVQ6404	AVQ-160 AVL-160 ALQ-160	159,2	53	18	5	4,5	M12 x 1,75 P	98,4	153,00
Z.KS.ST.AVQ8404	AVQ-200 AVL-200 ALQ-200 AOM-200	200	56	18	4	5	M12 x 1,75 P	120	272,00
Z.KS.ST.HP503L	HP-50 MP-50	130	46	15	5	5	5/16 - 18 UNC	85	101,00
Z.KS.ST.HP603L	HP-60 MP-60	154	54	17	5	5	3/8 - 16 UNC	100	111,00
Z.KS.ST.HP803L	HP-80 MP-80	206	62	21	5,5	6	M10 x 1,5 P	120	205,00
Z.KS.ST.AVC6404	AVC-160 AVM-160	160	58	15	5	5	M10 x 1,5 P	90	133,00
Z.KS.ST.AVC8404	AVC-200 AVM-200	200	63	18	5	5	M12 x 1,75 P	120	282,00
Z.KS.ST.TLD4402	TLD-40	102	38	15	8	5	3/8 - 16 UNC	63,5	183,00
Z.KS.ST.ALD6401	ALD-60	152	58	17	8	5	M12 x 1,75 P	95	183,00

Verwendung:

Für das horizontale Spannen von flachen Werkstücken

Application:

For horizontal clamping of flat workpieces

Usage:

Pour le serrage horizontal de pièces plates

Werkstoff:

Stahl S50C | Gehärtet HRC 53 +/-2

Material:

Steel S50C | Hardened HRC 53 +/-2

Matériel:

Acier S50C | Trempé HRC 53 +/-2



Geriffelte Backen / Rillenbacken (Paar)

Serrated jaws (Pair)
Mors cannelés (Paire)

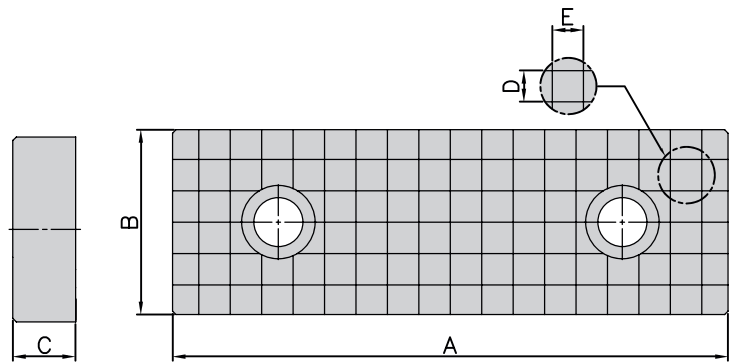
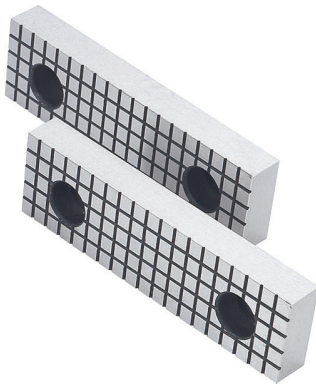

Bestell-Nr. Order no. Référence	Ausführung Version Version	A	B	C	D	E	EUR	
Z.KS.GR.AT409T	ATW-40 ATD-460	102	35	15	9	9	196,00	
Z.KS.GR.AT509T	ATW-50 ATD-570	126	38,1	17	9	9	216,00	
Z.KS.GR.AT609T	ATW-675 ATW-689 MG-60 AMC-60 TLD-60 HLD-60	151	44,5	18	8	8	235,00	
Z.KS.GR.AT809T	ATW-810	206	60	24,2	8	8	338,00	
Z.KS.GR.AMC409T	AMC-40	102	40	21	9	9	193,00	
Z.KS.GR.AVQ4405	AVQ-100 AVL-100	102	45	15	9	9	216,00	
Z.KS.GR.AVQ5405	AVQ-125 AVL-125	124,7	53	15	9	9	242,00	
Z.KS.GR.AVQ6405	AVQ-160 AVL-160 ALQ-160 AOM-160	159,2	53	18	9	9	282,00	
Z.KS.GR.AVQ8405	AVQ-200 AVL-200 ALQ-200 AOM-200	200	56	18	9	9	331,00	
Z.KS.GR.HP503T	HP-50 MP-50	130	46	15	8	8	209,00	
Z.KS.GR.HP603T	HP-60 MP-60	154	54	17	8	8	276,00	
Z.KS.GR.HP803T	HP-80 MP-80	206	100	30	8	8	397,00	
Z.KS.GR.AVC6405	AVC AVM-160	160	58	15	8	8	262,00	
Z.KS.GR.AVC8405	AVC AVM-200	200	63	18	8	8	348,00	
Z.KS.GR.TLD4405	TLD-40	2 Paar 2 pair 2 paire	102	38	15	9	9	434,00
Z.KS.GR.ALD6405	ALD-60	2 Paar 2 pair 2 paire	152	58	49	25	25	486,00

11

Verwendung:

Zur Erhöhung der spezifischen Flächenpressung

Application:

To increase the specific contact pressure per unit area

Usage:

Pour augmentation de la pression spécifique de la surface

Werkstoff:

Stahl S50C | Gehärtet HRC 53 +/-2

Material:

Steel S50C | Hardened HRC 53 +/-2

Matériel:

Acier S50C | Trempé HRC 53 +/-2

Niederzugbacken (Paar)



Hold down jaws (Pair)

Mors de tirage vers le bas (Paire)

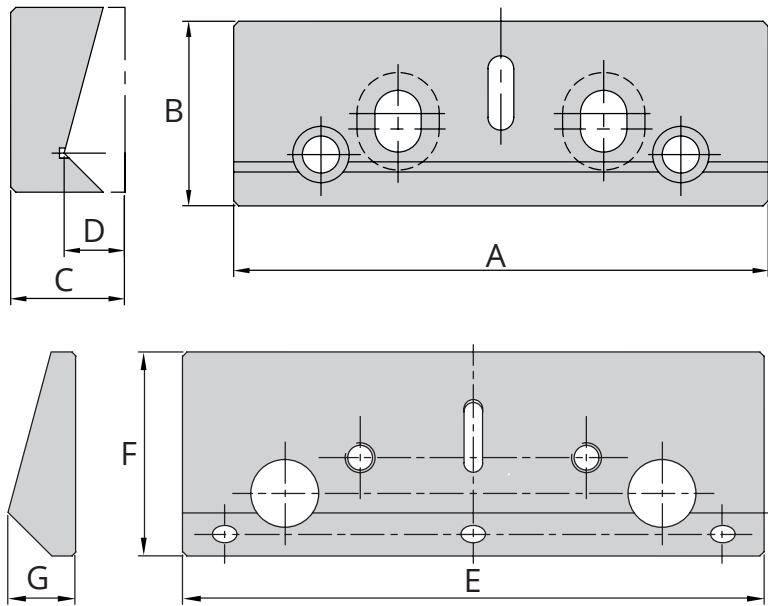

Bestell-Nr. Order no. Référence	Ausführung Version Version	A	B	C	D	E	F	G	EUR
Z.KS.NZ.HP503DA	HP-50 MP-50	130	46	26,4	15,1	130	46	15,1	265,00
Z.KS.NZ.HP603DA	HP-60 MP-60	154	54	29,4	18	154	54	18	292,00
Z.KS.NZ.HP803DA	HP-80 MP-80	206	62	29,4	21	206	62	21	391,00

Verwendung:

Hohe Stabilität bei der Werkstückbearbeitung durch aktiven Niederzug

Application:

High stability during workpiece machining due to the active pull-down

Usage:

Haute résistance lors de l'usinage de la pièce grâce à une traction vers le bas en mode actif

Werkstoff:

Stahl S50C | Gehärtet HRC 53 +/-2

Material:

Steel S50C | Hardened HRC 53 +/-2

Matériel:

Acier S50C | Trempé HRC 53 +/-2



Krallenbacken (Paar)

Claw jaws (Pair)
Mors à griffes (Paire)

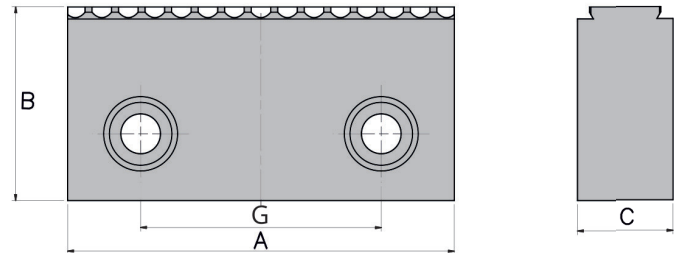

Bestell-Nr. Order no. Référence	Ausführung Version Version	A	B	C	G	EUR
Doppelverzahnung double toothing double denture						
Z.KS.KB.ATD409	ATW-40 / ATD-460	102	50,8	25,4	63,5	270,00
Z.KS.KB.ATD509	ATW-50 / ATD-570	126	57,15	25,4	79,4	290,00
Z.KS.KB.ATL609	ATW-675 u.a.	152,4	63,5	25,4	98,4	260,00
Z.KS.KB.ATL809	ATW-810	203	63,5	25,4	120	415,00
Einfachverzahnung single toothing denture unique						
Z.KS.KB.AVQ5401	AVQ-125 AVL-125	124,7	58,0	18,0	60	270,00
Z.KS.KB.AVQ6401	AVQ AVL ALQ -160	159,2	58	20	98,4	290,00
Z.KS.KB.AVQ8401	AVQ AVL ALQ AOM-200	199,5	63	20	120	420,00

Verwendung:

Drei bis vier Mal höhere Haltekräfte als Standard-Aufsatzbacken

Application:

High clamping forces: increased by three or four times compared to standard top jaws

Usage:

Force de maintien trois à quatre fois plus élevée par rapport aux mors standards

11

Werkstoff:

Stahl S50C | Gehärtet HRC 53 +/-2

Material:

Steel S50C | Hardened HRC 53 +/-2

Matériel:

Acier S50C | Trempé HRC 53 +/-2

Knarre mit Nuss für ALQ, AVQ und AVL Schraubstöcke



Ratched with nut for ALQ, AVQ and AVL vices

Clé à cliquet avec douille pour les etaux ALQ, AVQ et AVL



Bestell-Nr.
Order no.
Référence

DRVS

EUR

Z.KS.OB5020.OB5032

19

59,00

Handkurbel für ALQ, AVQ und AVL Schraubstöcke

Handle for ALQ, AVQ and AVL vices

Poignée de manivelle pour les etaux ALQ, AVQ et AVL



Bestell-Nr.
Order no.
Référence

DRVS

EUR

Z.KS.ALQ629A

19

49,00

11



Werkstückanschlag ATW

Workpiece stop ATW
Dispositif de butée ATW

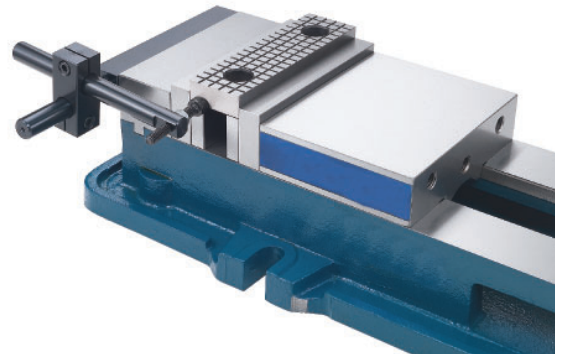
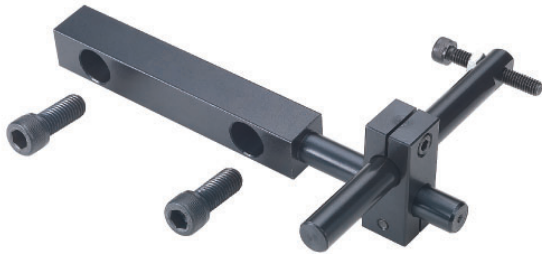

Bestell-Nr. Order no. Référence	Ausführung Version Version	EUR
Z.KS.ATW40ST	4" ATW-40 ATD-460	111,00
Z.KS.ATW50ST	5" ATW-50 ATD-570	126,00
Z.KS.ATW60ST	6" ATW-675 ATW-689	158,00
Z.KS.ATW80ST	8" ATW-810	205,00

Ausführung:

Stufenlose und schnelle Einstellung.

Direktmontage auf Standard-Vorsatzbacken bei NC-Schraubstöcken.

Verwendung:

Für den Einsatz auf Fräs- und Bohrmaschinen.

Version:

Stepless and quick adjustment.

Direct mounting on standard front jaws for NC vices.

Application:

For use on milling and drilling machines.

Version:

Réglage continu et rapide.

Montage direct sur les mors standards pour les étaux NC.

Usage:

Pour l'usage sur les machines de fraisage et les machines de perçage.

Workpiece back-stop, universal 3-dimensional
Dispositif de butée, universel 3D



Bestell-Nr. Order no. Référence	Ausführung Version Version	EUR
Z.KS.ATS160BH	ATS-160BH / T-16mm	227,00

Ausführung:

5 Achsen stufenlos 360° drehbar.
Stufenlose und schnelle Einstellung.
M8-Aufnahme für Nutensteine oder Direktmontage.

Verwendung:

Für den Einsatz auf Fräs- und Bohrmaschinen.

Werkstoff:

Aluminium eloxiert

Version:

*5 axes with stepless 360° rotation.
Quick and stepless adjustment.
M8 mounting for T-nuts or direct mounting.*

Application:

For use on milling and drilling machines.

Material:

Anodised aluminium.

Version:

5 axes à réglage continu, rotation à 360°.
Réglage continu et rapide.
Réception M8 pour écrous à rainure ou pour installation directe.

Usage:

Pour l'usage sur les machines de fraisage et les machines de perçage.

Matière(s):

Aluminium anodisé.



Winkelprisma, einstellbar

Adjustable prism square
Équerre à prisme, ajustable

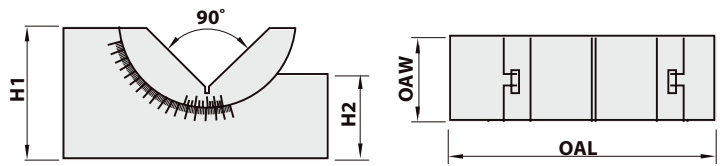

Bestell-Nr. Order no. Référence	OAL	OAW	H1	H2	EUR
GAP-25	75	25	36	25	165,00
GAP-30	102	30	49	30	189,00
GAP-46	102	46	49	30	219,00

Ausführung:

Aus gehärtetem Stahl, entspannt und feingeschliffen.
Winkelablesung bzw. Einstellung über Nonius.
Mit Feststellschraube arretierbar.

Winkelgenauigkeit = 10 Winkelmin.
Winkelablesung = 10 Winkelmin.
Ebenheitstoleranz = 0,01mm

Version:

Made of hardened steel, stress-relieved and finely ground.
Angle reading or setting via vernier.
Lockable with locking screw.

Angular accuracy = 10 angle min.
Angle reading = 10 angle min.
Flatness tolerance = 0.01mm

Version:

Fabriqué en acier trempé, détendu et finement rectifié.
Lecture d'angle ou réglage par vernier.
Peut être bloqué avec une vis de blocage.

Précision angulaire = 10 angle min.
Mesure d'angle = 10 angle min.
Tolérance de planéité = 0,01 mm

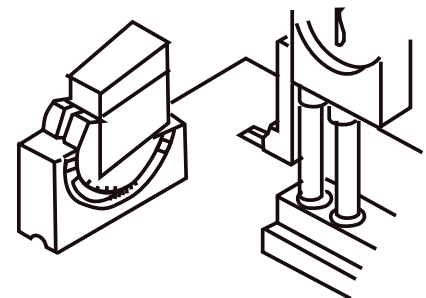
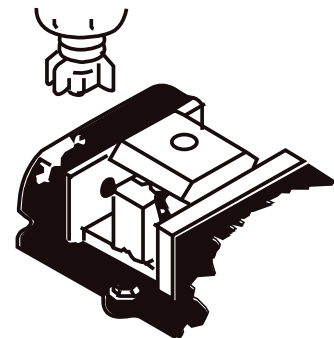

Clamping sets 4-parts

Jeu de brides de serrage 4 pieces



Verwendung:

Zum konventionellen Befestigen auf dem Maschinentisch.

Application:

For conventional fastening to the machine table.

Usage:

Pour la fixation standard sur la table de la machine.

Bestell-Nr. Order no. Référence	Ausführung Version Version	EUR
Z.KS.AVQ690102	14mm T-Nut	70,00
Z.KS.AVQ690104	16mm T-Nut	76,00
Z.KS.AVQ690106	18mm T-Nut	84,00
Z.KS.AVQ690105	20mm T-Nut	95,00

Zentrier-Nutensteine (Paar)

Centering nut (Pair)

Coulisseaux de centrage (Paire)



Bestell-Nr. Order no. Référence	Ausführung Version Version	EUR
Z.KS.N.ATD570-14	16 - 14	36,00
Z.KS.N.AVQ.18-12	18 - 12	36,00
Z.KS.N.ATW689-14	18 - 14	36,00
Z.KS.N.ATW689	18 - 16	36,00
Z.KS.N.STANDARD	18 - 18	36,00
Z.KS.N.ATW810	20 - 18	48,00



T-Nuten (T-Nutensteine mit Gewinde)

T-Nuts (T-nut with thread)

Tasseaux (Tasseau en forme T avec filetage)

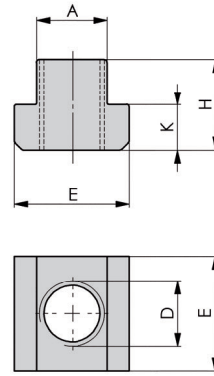

Bestell-Nr. Order no. Référence	Ausführung Version Version	A	D	E	H	K	EUR
Z.KS.80010	M6x8	7,7	M6	13	10	6	9,00
Z.KS.80028	M8x10	9,7	M8	15	12	6	9,00
Z.KS.80036	M10x12	11,7	M10	18	14	7	16,00
Z.KS.80234	M10x14	13,7	M10	22	16	8	16,00
Z.KS.80366	M10x16	15,7	M10	25	18	9	16,00
Z.KS.81265	M10x18	17,7	M10	28	20	10	16,00
Z.KS.80168	M12x16	15,7	M12	25	18	9	16,00
Z.KS.80051	M14x16	15,7	M14	25	18	9	16,00
Z.KS.80176	M14x18	17,7	M14	28	20	10	16,00
Z.KS.80077	M18x20	19,7	M18	32	24	12	28,00
Z.KS.80242	M18x22	21,7	M18	35	28	14	28,00
Z.KS.80093	M22x24	23,7	M22	40	32	16	30,00

Verwendung:

Zur Kombination mit Stiftschrauben nach Norm.

Norm:

DIN 508

Werkstoff:

Vergütungsstahl, Festigkeit 10.

Hinweis:

Volle Belastbarkeit nur bei Verschraubung über die gesamte Gewindelänge.

Application:

For combination with studs or bolts.

Standard:

DIN 508

Material:

Quenched and tempered steel, strength 10.

Note:

Full load-bearing capacity only when threaded for the entire nut length.

Utilisation:

Pour la fixation avec des goujons selon la norme.

Norme:

DIN 508

Matière(s):

Acier trempé et revenu, résistance 10.

Remarque(s):

Capacité de charge maximale uniquement en cas de fixation sur toute la longueur du filetage.

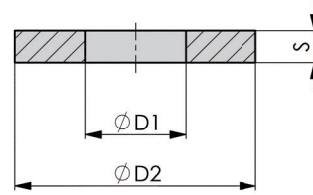
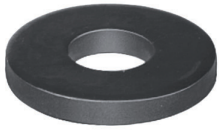

Bestell-Nr. Order no. Référence	Ausführung Version Version	D1	D2	S	EUR
Z.KS.82818	M6	6,4	17	2	6,00
Z.KS.82826	M8	8,4	23	4	6,00
Z.KS.82834	M10	10,5	28	4	6,00
Z.KS.82859	M14	15	40	5	6,00
Z.KS.82875	M18	19	45	6	6,00
Z.KS.82891	M22	23	50	8	9,00

Ausführung:

Extra stark, plan gepresst und gehärtet, Kanten gebrochen.

Verwendung:

Besonders geeignet für Spanneisen.

Speziell für den Vorrichtungsbau.

Norm:

DIN 6340

Version:

Extra strong, flat-pressed and hardened, edges bevelled.

Application:

Particularly suitable for clamps.

Especially for making jigs and fixtures.

Standard:

DIN 6340

Version:

Extra fort, pressé à plat et durci, arêtes brisées.

Usage:

Convient particulièrement pour les brides de serrage.

Spécial pour la construction de montages.

Norme:

DIN 6340



Stiftschrauben DIN 6379

Studs DIN 6379
Goujons DIN 6379

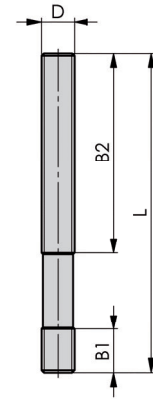

Bestell-Nr. Order no. Référence	Ausführung Version Version	B1	B2	EUR
Z.KS.84780	M6x50	9	30	10,00
Z.KS.81257	M8x40	11	20	10,00
Z.KS.81299	M10x50	13	25	10,00
Z.KS.84830	M10x80	13	50	10,00
Z.KS.81372	M14x63	17	32	15,00
Z.KS.84954	M18x125	23	75	20,00
Z.KS.86561	M18x160	23	100	20,00
Z.KS.81539	M22x160	31	100	30,00

Ausführung:

Gewinde gerollt

Verwendung:

Zum individuellen Zusammenstellen von T-Nuten-Schrauben in Verbindung mit Nutensteinen, Muttern und Unterlegscheiben.

Norm:

DIN 6379

Werkstoff:

Vergütungsstahl

Festigkeitsklasse:

M6 – M12 = 10.9

M14 – M30 = 8.8

Version:

Rolled thread.

Application:

For individual combination of T-bolts in conjunction with T-nuts and tenons, nuts and plain washers.

Standard:

DIN 6379

Material:

Heat-treated steel

Strength class:

M6 – M12 = 10.9

M14 – M30 = 8.8

11

Version:

Filet roulé.

Utilisation:

Pour l'usage avec les vis pour rainures en forme T ensemble avec les tasseaux, les écrous et les écrous.

Norme:

DIN 6379

Matière(s):

Acier trempé et revenu

Catégorie de résistance:

M6 – M12 = 10.9

M14 – M30 = 8.8

Fixture nuts DIN 6330B
Écrou hexagonal DIN 6330B

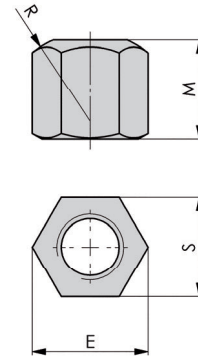

Bestell-Nr. Order no. Référence	Ausführung Version Version	E	M	R	S	EUR
Z.KS.82362	M6	11,05	9	9	10	8,00
Z.KS.82370	M8	14,40	12	12	13	8,00
Z.KS.82354	M10	17,80	15	15	16	8,00
Z.KS.82321	M14	23,40	21	20	21	8,00
Z.KS.82420	M18	30,10	27	24	27	10,00
Z.KS.82339	M22	37,70	33	30	34	10,00

Ausführung:

Hohe Mutter (= 1,5 d hoch) mit einem flachen Ende zur Auflage auf Unterlegscheiben DIN 6340 und einem kugeligen Ende zur Auflage in Kegelpfannen DIN 6319D oder DIN 6319G.

Norm:

DIN 6330 B

Werkstoff:

Vergütungsstahl, Festigkeit 10.

Version:

Tall nut (= 1.5 d tall) with one flat face to rest on plain washer DIN 6340 and a convex face for positioning in collared washer DIN 6319D oder DIN 6319G.

Standard:

DIN 6330 B

Material:

Quenched and tempered steel, strength 10.

Version:

Écrou long (= 1,5 d de hauteur) avec la surface plate destinée à être posée sur une rondelle plate DIN 6340 et avec la surface sphérique destinée à être posée sur une rondelle à collerette DIN 6319D ou DIN 6319G.

Norme:

DIN 6330 B

Matière(s):

Acier trempé et revenu, résistance 10.

K Drehplatte

Swivel base
Plateau tournant

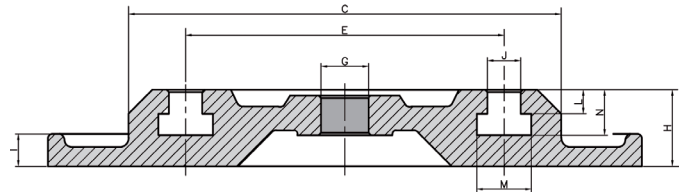
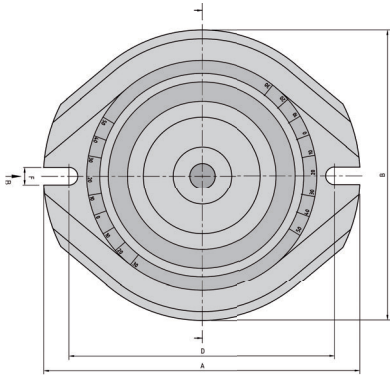

Bestell-Nr. Order no. Référence	Ausführung Version Version	A	B	C	D	E	F	G	H	I	J	L	M	N	EUR
Z.KS.HP502A	HP-50 / MP-50	272	260	212	239	160	18	16	33	33	14	10	26	22	142,00
Z.KS.HP602A	HP-60 / MP-60	327	322	255	286	201	20	16	37	37	18	12	32	23	155,00
Z.KS.HP802A	HP-80 / MP-80	410	410	305	370	240	20	16	46	46	18	15	36	27	309,00
Z.KS.AT413A	ATW-40 / ATD-460	250	230	182	210	134	14	20	32	13,5	14	10	23,5	19	133,00
Z.KS.AT513A	ATW-50 / ATD-570	275	257	212	239	163	14	20	36	13,5	14	10	23,5	19	142,00
Z.KS.AT613A	ATW-675 / ATW689	320	300	255	280	191	20	25	42	14,5	17,5	13	34	30	155,00
Z.KS.AT813A	ATW-810	400	380	320	356	250	20	30	49	20	17	15	32	33	309,00

Merkmal:

Auflagerand geschliffen, 360° Teilstriche zur Winkeleinstellung, Fixiernut 16H / 20H7.

Feature:

Bearing edge ground, 360° graduations for angular adjustment, 16H7 / 20H7 fixing slot.

Caractéristique(s):

Bord de support rectifié, graduations de 360° pour le réglage de l'angle, rainure de fixation 16H / 20H7.

Clamping sets / Basic assortment of clamping elements
 Jeux de serrage / Ensemble d'outils de serrage de base



Verwendung:
 Zum konventionellen Befestigen auf dem Maschinentisch.

Application:
 For conventional fastening to the machine table.

Usage:
 Pour la fixation standard sur la table de la machine.

Bestell-Nr. Order no. Référence	Gewinde Thread Filetage	T-Nuten-Nennmaß T-slot nominal size Dim. nom. rain. T	EUR
Z.KS.ACK08	M8x1,25	10mm T-Nut	157,00
Z.KS.ACK10	M10x1,5	12mm T-Nut	157,00
Z.KS.ACK12A	M12x1,75	14mm T-Nut	167,00
Z.KS.ACK12B	M12x1,75	16mm T-Nut	167,00
Z.KS.ACK12C	M12x1,75	18mm T-Nut	167,00

Merkmal:
 Alle Teile aus Vergütungsstahl gefertigt.
 T-Nutenschrauben vergütet, Gewinde gerollt.

Feature:
 All parts made of quenched and tempered steel.
 T-slot bolts quenched and tempered, rolled thread.

Caractéristique(s):
 Toutes les pièces sont fabriquées en acier trempé et revenu
 Vis à rainure en forme T trempées, filetage roulé.

Parallel-Unterlagen-Sätze

Set of parallel supports
 Jeu de supports parallèles



Verwendung:
 Parallelunterlagen finden vielseitige Verwendung als Hilfsmittel zum Spannen und Positionieren z.B. beim Schleifen, Fräsen, Erodieren, Messen und Anreissen.

Application:
 Parallels are widely used for clamping and positioning, f.e. during grinding, milling, eroding, measuring and scribing.

Usinage:
 Les jeux de supports parallèles sont souvent utilisés comme outils de serrage et de placement, par exemple pour la rectification, le fraisage, l'érosion, la mesure et le traçage.

Bestell-Nr. Order no. Référence	Anzahl Leisten Number of strips Nombre de cales	OAL	OAB	OAH	EUR
91.12.150.1	14 Paar / pairs / paires	150	10	14 - 16 - 18 - 20 - 22 - 24 - 26 - 28 - 30 - 32 - 35 - 40 - 45 - 50	200,00
91.12.150.2	14 Paar / pairs / paires	150	8	14 - 16 - 18 - 20 - 22 - 24 - 26 - 28 - 30 - 32 - 35 - 40 - 45 - 50	200,00
91.12.200.3	14 Paar / pairs / paires	200	10	14 - 16 - 18 - 20 - 22 - 24 - 26 - 28 - 30 - 32 - 35 - 40 - 45 - 50	263,00

91.13.100.1	9 Paar / pairs / paires	100	4	10 - 14 - 18 - 22 - 26 - 30 - 34 - 38 - 42	168,00
Härte:	HRC 55 - 62	Genauigkeit:	0,01mm	Parallelität:	0,005mm
Hardness:	HRC 55 - 62	Accuracy:	0,01mm	Parallelism:	0,005mm
Dureté:	HRC 55 - 62	Exactitude:	0,01mm	Parallélisme:	0,005mm