

POWER CHUCKS CYLINDERS / STEADY RESTS

EDITION 8.1

RÖHM
driven by technology



RÖHM

Table of contents

POWER CHUCKS | CYLINDERS | STEADY RESTS

Power chucks with through-hole

DURO-A	6014
KFD-HS	6025
KFD-HE	6036
KFG	6046
PKF	6050

Power chucks without through-hole

KFD-EC	6056
KFD	6071
KFD-G	6072

Power chucks with quick jaw change system

DURO-A RC	6078
DURO-NCSE	6088
DURO-NC	6098

Air-operated self-contained chucks

LVE	6112
LVE - large through-hole	6118

Application chucks

Ball lock draw-down chuck KBF-N	6130
Power-operated draw bar chuck ZFM	6134
Power-operated compensating chuck KFD-AF	6136
Gripper chuck GF	6140

Cylinder with through-hole

SZS	6148
LHS-L	6150

Cylinder without through-hole

OVS	6156
LVS	6160

Self-centering steady rests

SLZN	6170
SLZNB	6174
SLZ	6178
SLZC	6180
SLZK	6182

Stationary power chucks

KZS-P / KZS-PG	6190
KZS-H / KZS-HG	6196
SSP	6202

Clamping force measurement device

F-senso chuck	6208
---------------	------

Zero point clamping system

EASYLOCK	6209
----------	------



Operation guide



TYPE	DURO-A	KFD-HS	KFD-HE	KFG	PKF
	Power chucks with through-hole				
Feature	Constant clamping force distribution for more than 500,000 cycles	larger than average through-hole, high clamping precision, low centrifugal force losses	large through-hole, proven standard	large through-hole, large jaw stroke	maximum concentricity and axial run-out precision
Size	110 - 400	110 - 400	170 - 315	160 - 350	100 - 200
Chucking capacities	6 - 478 mm	6 - 478 mm	20 - 393 mm	5 - 472 mm	-
Power transmission	wedge	wedge	wedge	angle lever	wedge
Clamping force	████████	████████	████████	███	███
Speeds	████████	████████	████████	███	███
Number of jaws					
Type of jaws					pin mounting
Workpiece					
Machining					
Mount	 ISO 702-4 ISO 702-1	 DIN 6353 ISO 702-1 (DIN 55026) DIN 55021	 DIN 6353		
Page	6014	6025	6036	6046	6050



2-jaw chuck



serration 60°



pipe



flange



3-jaw chuck



serration 90°



bar



asymmetrical workpiece



tongue and groove



disc

Operation guide



TYPE	KFD-EC	KFD	KFD-G
	Power chucks without through-hole		
Feature	low-maintenance and -wear	proven standard chuck for numerous applications	large jaw stroke, reduced interference contours
Size	200 - 400	85 - 630	125 - 315
Chucking capacities	16 - 490 mm	4 - 720 mm	-
Power transmission	wedge	wedge	wedge
Clamping force			
Speeds			
Number of jaws			
Type of jaws			
Workpiece			
Machining			
Mount	 DIN 6353	 DIN 6353 similar DIN 6353	
Page	6056	6061	6072

- side machining
- length machining

- short taper mount
- cylindrical centre mount

Operation guide



TYPE	DURO-A RC	DURO-NCSE	DURO-NC	LVE	LVE large through-hole
	Power chucks with quick jaw change system			Air-operated self-contained chucks	
Feature	individual jaw unlocking	individual jaw unlocking	central jaw unlocking	incorporated actuating cylinder	incorporated actuating cylinder, large through-hole
Size	180 - 400	180 - 630	140 - 630	125 - 315	400 - 1000
Chucking capacities	11 - 351 mm	11 - 667 mm	5 - 780 mm	12 - 400 mm	85 - 1135 mm
Power transmission	wedge bar	wedge bar	wedge	wedge	wedge
Clamping force	■■■■□	■■■■□	■■■■□	■■■□□	■■■□□
Speeds	■■■■■	■■■■■	■■■■□	■■□□□	■■□□□
Number of jaws					
Type of jaws					
Workpiece					
Machining					
Mount					
Page	6078	6088	6098	6112	6118



2-jaw chuck



serration 60°



pipe



flange



3-jaw chuck



serration 90°



bar



asymmetrical workpiece



tongue and groove



disc

Operation guide



TYPE	KBF-N draw-down chuck	ZFM draw-down chuck	KFD-AF compensating chuck	GF gripper chuck
	Application chucks			
Feature	for internal and external clamping, active pull down, hermetically sealed with oil bath lubrication	active pull down, only external clamping	compensating jaws, interchangeable centering inserts	automatic jaw resetting
Size	170 - 400	160 - 315	160 - 315	80 - 125
Chucking capacities	-	-	5 - 393 mm	-
Power transmission	wedge	draw rod studs system	wedge	spring system
Clamping force				
Speeds				stationary
Number of jaws				
Type of jaws		-		
Workpiece				
Machining				no machining (only gripping and positioning)
Mount	 DIN 6353	 ISO 702-1 (DIN 55026) DIN 55021	 with option for radial fine adjustment	cylindrical shank DIN 69880
Page	6130	6134	61236	6140

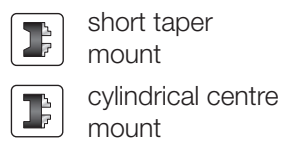
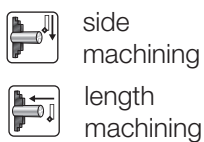

Operation guide

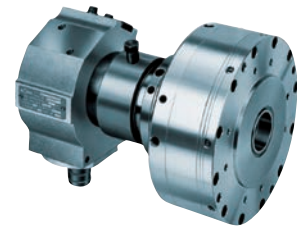

TYPE	SZS	LHS-L
	Cylinder with through-hole	
Feature	hydraulic cylinder with through-hole for operating pressure 8 - 45 bar	pneumatic cylinder with through-hole for operating pressure 1,5 - 8 bar
Through-hole	46 - 127 mm	26 - 42 mm
Stroke max.	25 - 40 mm	20 - 32 mm
Pull force	46 - 145 kN (45 bar operating pressure)	10 - 16 kN (6 bar operating pressure)
Actuation		
Max. Speeds	7000 - 3200 m ⁻¹	6500 - 4000 m ⁻¹
Installation position	horizontal	horizontal, vertical
Feature	short design	short design
Workpiece		
Page	6148	6150



2-jaw chuck



serration 60°



pipe



flange



3-jaw chuck



serration 90°



bar



asymmetrical workpiece



tongue and groove



disc

Operation guide



TYPE	OVS	LVS
	Cylinder without through-hole	
Feature	hydraulic cylinder without through-hole for operating pressure 8 - 80 bar	pneumatic cylinder without through-hole for operating pressure 2 - 10 bar
Through-hole	-	-
Stroke max.	32 - 50 mm	32 - 45 mm
Pull force	30 - 166 kN (60 bar operation pressure)	3 - 57 kN (6 operating pressure)
Actuation		
Max. Speeds	8000 - 4500 m ⁻¹	5000 - 3200 m ⁻¹
Installation position	horizontal, vertical	horizontal, vertical
Feature	prepared for media feed-through	media feed-through on request
Workpiece		
Page	6156	6160

Operation guide

- side machining
- length machining

- short taper mount
- cylindrical centre mount

- hydraulic actuated
- pneumatically actuated

Operation guide



TYPE	SLZN	SLZNB	SLZ	SLZC	SLZK
	Self-centering steady rests				
Feature	standard version with cylinder mounted at rear	with side mounted cylinder	heavy design for high loads	compact design, extra large clamping range	slim clamping arms
Chucking capacities	4 - 350	8 - 350	40 - 800	60 - 520	8 - 250
Max. clamping force per roller	1040 - 16000 N	3500 - 16000 N	35000 - 80000 N	14500 - 25000 N	2700 - 7500 N
Centering accuracy over the entire clamping range	0,02 - 0,06*	0,02 - 0,06*	0,04 - 0,06*	0,05 - 0,06*	0,03 - 0,06*
Repeatability at same clamping-Ø	0,005 - 0,01*	0,005 - 0,01*	0,01*	0,007 - 0,01*	0,007 - 0,01*
Rollers	cylindrical or convex	cylindrical or convex	cylindrical or convex	cylindrical or convex	cylindrical
Chip protection	with and without	with and without	with and without	with and without	with and without
Page	6170	6174	6178	6180	6182

* At constant pressure



2-jaw chuck



serration 60°



pipe



flange



3-jaw chuck



serration 90°



bar



asymmetrical workpiece



tongue and groove



disc

Operation guide



TYPE	KZS-P / KZS-PG	KZS-H / KZS-HG	SSP	F-senso chuck
	Stationary power chucks			Clamping force measurement device
Feature	pneumatically, centering vices, KZS-PG with long jaw movement	hydraulically, centering vices, KZS-HG with long jaw movement	pneumatically, without through-hole	measurement device incl. tablet and software
Size	64 - 250	64 - 250	160 - 315	-
Chucking capacities	-	-	28 - 400	75 - 175
Power transmission	wedge	wedge	wedge	-
Clamping force				max. 300 kN
Speeds	stationary	stationary	-	max. 8250 min ⁻¹
Number of jaws				2-jaw (stationary) 3-jaw (rotating)
Type of jaws				-
Workpiece				-
Machining				-
Mount	clamping sleeve DIN 7346	clamping sleeve DIN 7346	flange	-
Speciality	optimally suited for automated work sequences	optimally suited for automated work sequences	serration 60°, tongue and groove and / or through-hole on request	delivered in the practical hard-shell case
Page	6190	6196	6202	6209

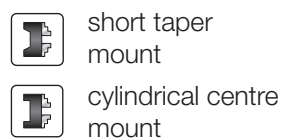
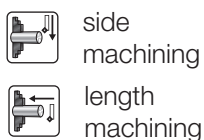

Flexibility of the media feed-through

For power chucks with and without through-hole

Available on request:

- ⊕ With air feed-through for air sensing, purge or blast air
- ⊕ Central lubrication
- ⊕ With guided and sealed piston neck
- ⊕ With water drain groove or water drain bore as well as cover or inserts for the through-hole bore

Examples of modified power chucks with feed-through for:

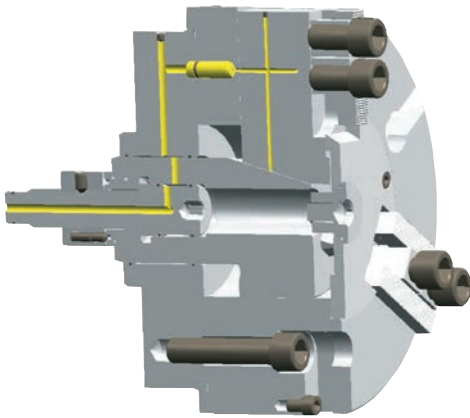

Central lubrication via distributor flange with dosing units

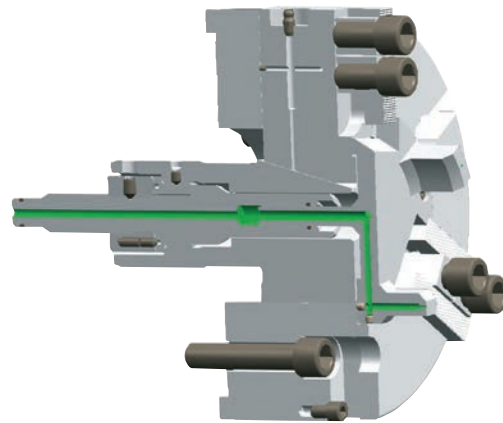

Air sensing

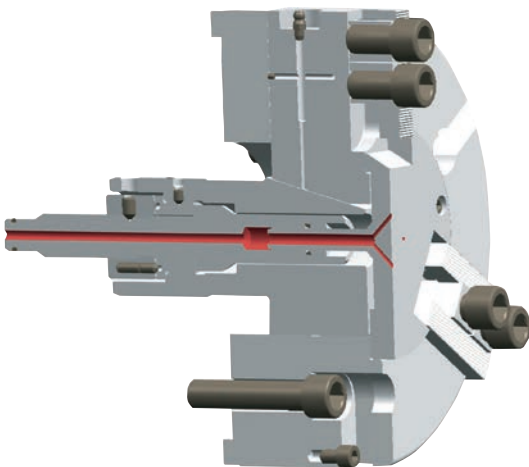

Blast air

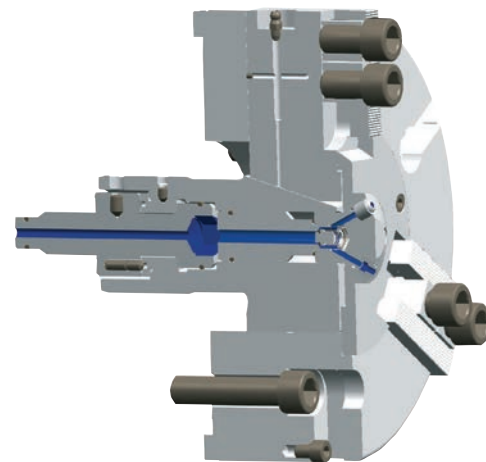

Coolant

Double feed-throughs, e.g. for central lubrication and air sensing, are possible.



Notes

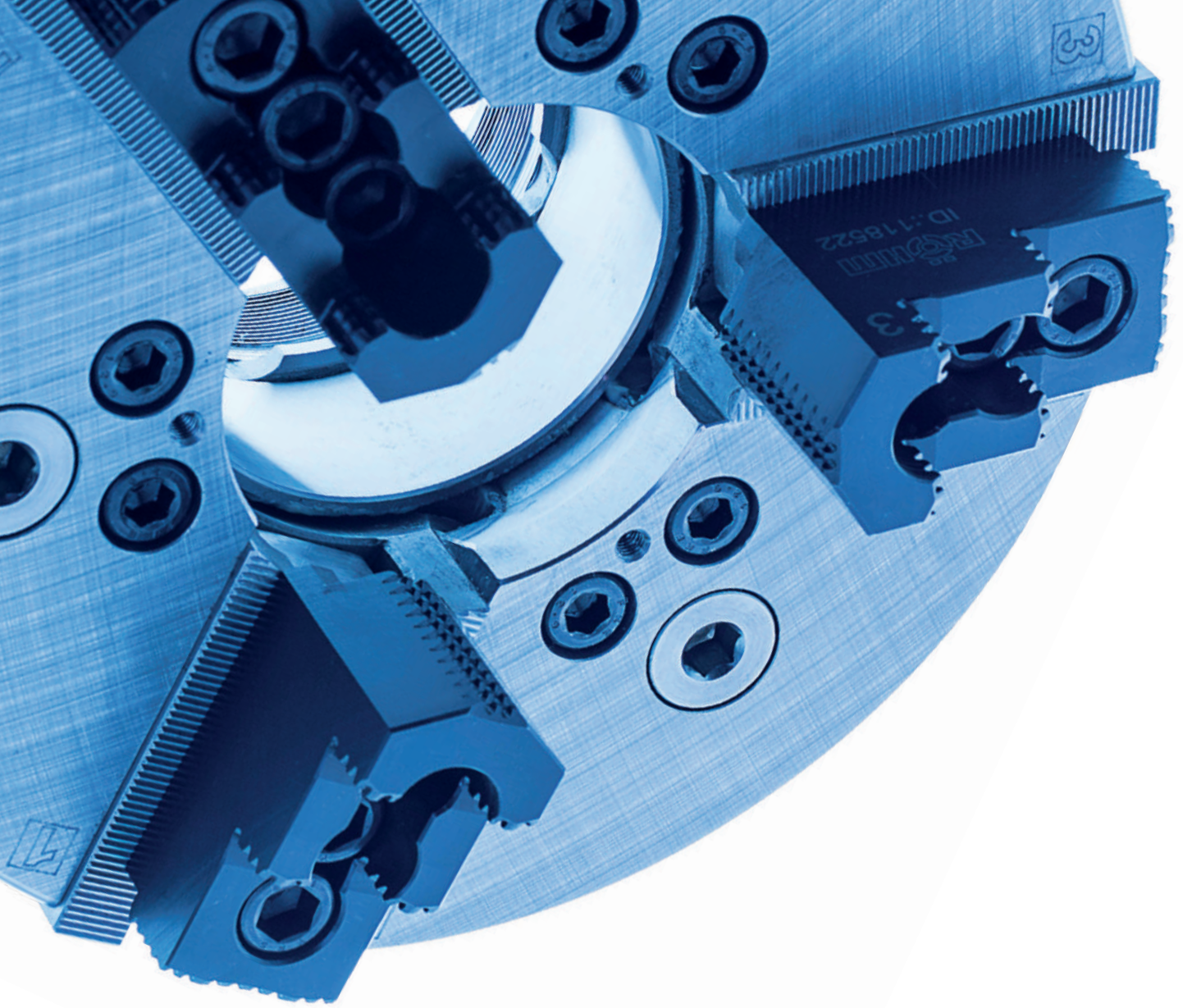

USED UNIVERSALLY FOR DECADES

Founded in 1909, RÖHM began successively expanding their product range by the area of power chuck technology starting in 1950. Decades of experience and knowledge about power chucks make today's RÖHM power chucks so successful. Especially for the machining of bar material, these are not only characterized by the high flexibility due to the large through-hole, but also by the long service life, top precision and reliability.



Power chucks with single wedge gate valve system and through-hole

POWER CHUCKS WITH THROUGH-HOLE

RÖHM power chucks with through-hole are successfully used both in bar and pipe machining, as well as in the machining of flange-type workpieces. The proven wedge system allows maximum clamping forces with maximum clamping precision at the same time. The rigidity of the power chucks which contributes to this is achieved with a sturdy chuck construction.

ADVANTAGES AT A GLANCE

- ⊕ Large through-hole optimal for bar machining
- ⊕ Proven power chucks with long service life
- ⊕ Wedge hook system for high load capacity and clamping precision

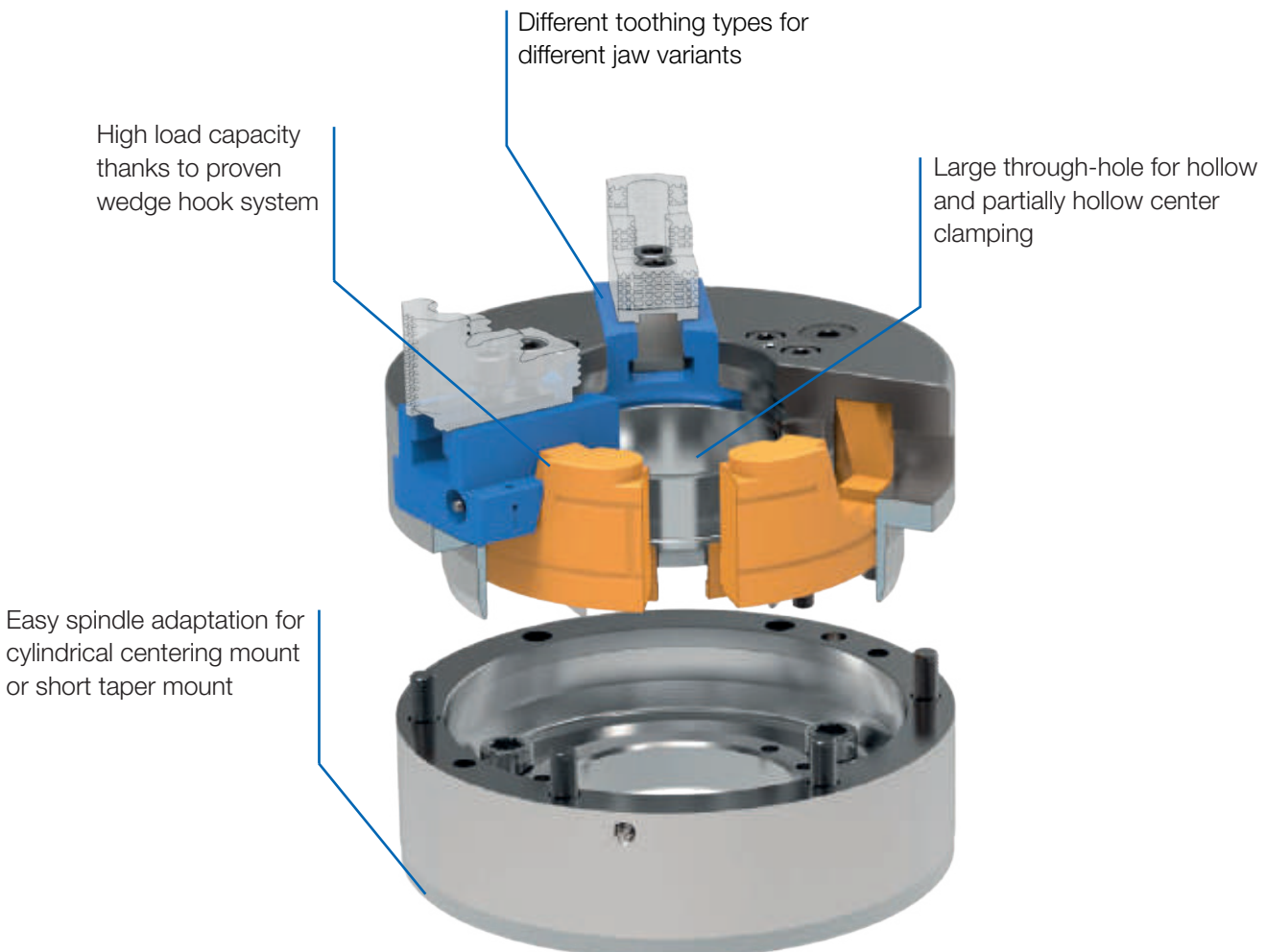

DURO-A - Constant clamping force for more than 500.000 cycles



APPLICATION

Premium power chuck with through-hole for the machining of bar, pipes and discs. With constant clamping force distribution for more than 500,000 cycles.

TYPE

Power chuck available with cylindrical centre mount. Connection dimensions according to DIN ISO 702-4. Adaption to short taper mount DIN ISO 702-1. 3-jaw version with serration 90° and 60°.

CUSTOMER BENEFITS

- ⊕ Constant clamping force for more than 500,000 cycles
- ⊕ Up to 30% higher maximum clamping force
- ⊕ 3-year warranty (pursuant to DURO-A warranty)
- ⊕ Weight reduction of up to 10% by reducing overall height, as well as increased work envelope due to improved interference contours

TECHNICAL FEATURES

- Up to 30% larger through-hole and up to 35% more maximum speed for a broader range of applications compared to similar power chucks
- Optimized centrifugal force behavior and low centrifugal force losses and high speeds thanks to special wedge hook system with annular piston
- High concentricity of 0.01 mm (for milled top jaws) through precision manufacturing

Included in the scope of delivery:

Chuck, chuck and jaw mounting screws, mounting wrench, slot nuts (without top jaws)

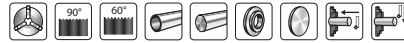

Gripping force/speed diagram (3-jaw chucks only)

The loss of gripping force was determined experimentally on a chuck with matched UB top jaws. It is largely independent of the initial gripping force at zero speed.

Upper curve:
min. centrifugal force of top jaw



Lower curve:
max. centrifugal force of top jaw



To obtain the specified gripping forces, the chuck must be in a perfect condition and lubricated with F 80 lubricant recommended by RÖHM. Measuring point near chuck face.

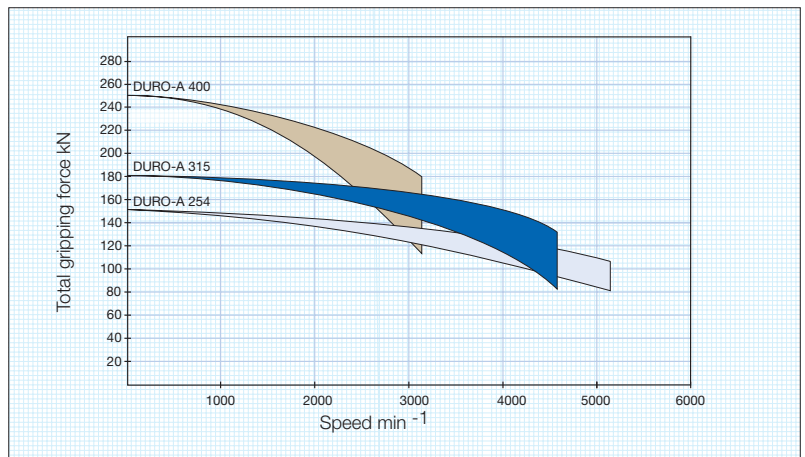
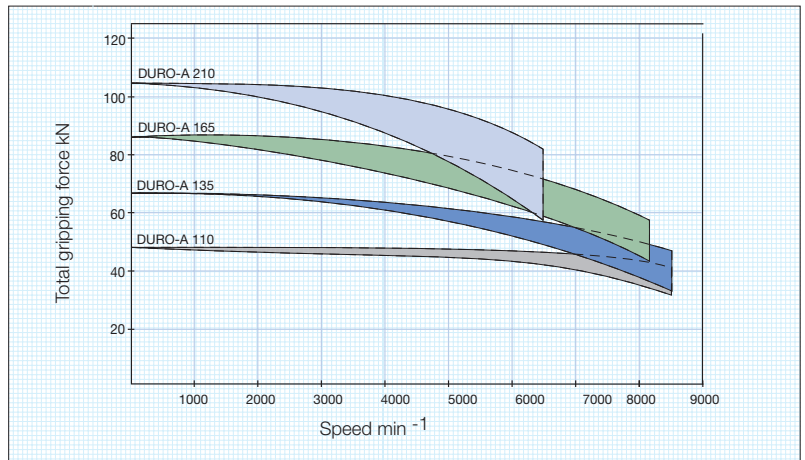

DURO-A, 3-jaws, serration 90°

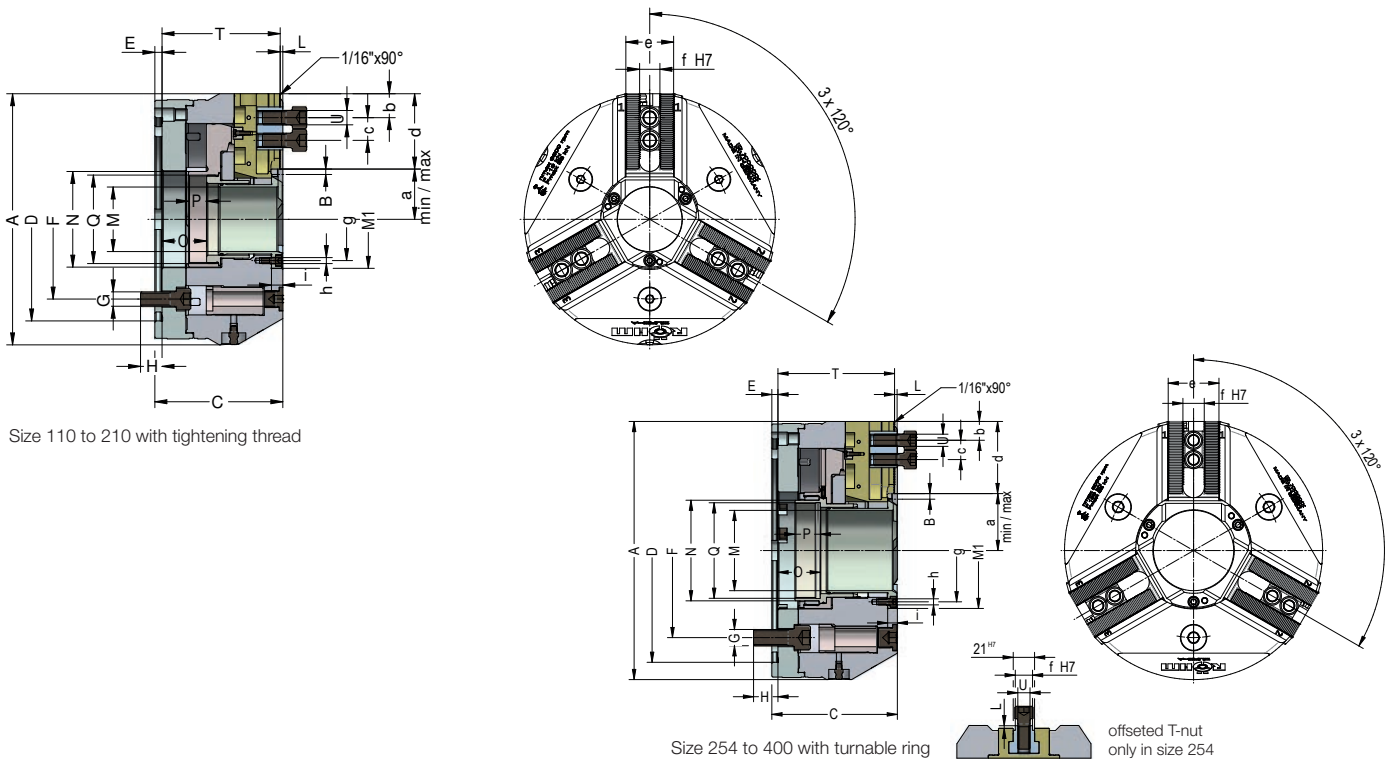

Size 110 to 210 with tightening thread

Size 254 to 400 with turnable ring

offset T-nut only in size 254

C 15

3-jaw power chuck **DURO-A**, serration 90°, cylindrical centre mount, connection dimensions according to **DIN ISO 702-4**

Item No.	183700	183701	183702	183703	183704	183705	183706	183707	183708
Size	110	135	165	210	254	254	315	315	400
Number of jaws	3	3	3	3	3	3	3	3	3
A mm	110	135	165	210	254	254	315	315	400
Jaw travel B mm	3.2	3.2	3.5	4.5	5.5	5.5	6.2	6.2	7.5
C mm	78	88	97	107	121	123.5	132.5	137	159.5
Mount D	ZA 60	ZA 115	ZA 140	ZA 170	ZA 170	ZA 220	ZA 220	ZA 300	ZA 380
E mm	6	6	6	6	6	6	6	6	6
F mm	82.6	82.6	104.8	133.4	133.4	171.4	171.4	235	330.2
G	3xM10	3xM10	3xM10	3xM12	3xM12	3xM16	3xM16	3xM20	3xM24
H mm	15	15	15	18	18	24	26.5	30	30
Wedge stroke K mm	12	12	13	17	20.5	20.5	23	23	28
L mm	2.5	2.2	2.2	2.2	2.5	2.5	2.5	2.5	3.2
M max. mm	27	34	46	54	79	79	98.5	98.5	133
M ^{H7} mm	52	59	74	82	114	114	140	140	180.5
N mm	38	45	58	80	99	99	121	121	157.5
O min.	10.5	15.5	17.5	20.3	18.7	21.2	22.1	26.6	30.6
O max.	22.5	27.5	30.5	37.3	39.2	41.7	45.1	49.6	58.6
P mm	11.5	13.5	15.5	15.3	25	25	25	25	35
Q mm	M34x1.5	M38x1.5	M54x1.5	M74x1.5	M94x1.5	M94x1.5	M114x2	M114x2	M148x2
T mm	71.3	79.3	88.8	98.8	112.3	114.8	121.8	126.3	144.3
U mm	M8	M6	M8	M12	M12	M12	M16	M16	M20
a min.	21.8	25.3	31.5	37.5	50.5	50.5	61.3	61.3	79.5
a max.	25	28.5	35	42	56	56	67.5	67.5	87
b min.	2.5	5.0	-1	15.5	15.5	15.5	15.5	15.5	20
b max.	8.5	7.5	12	34.5	42	42	51	51	62
c mm	14	2x12	2x15	19	19	19	25	25	31
d mm	30	39	47.5	63	71	71	90	90	113
e mm	24	25	32	40	50	50	50	50	60
fH7-0.025 mm	10	10	12	17	17	17	21	21	25.5
g mm	43	48	61	69	101	101	125	125	166
h	M4	M4	M5	M5	M6	M6	M6	M6	M8
i	6	6	7.5	9.5	9.5	9.5	11.5	11.5	20
Max. swing top jaws mm	136 (113 K)	170	195	260 (250 K)	305	305	402 (380 K)	402 (380 K)	520
Maximum draw bar pull kN	17	25	30	38	53	53	62	62	90
Max. total clamping force kN	48	70	86	110	150	150	180	180	250
Max. admissible speed min ⁻¹	8500	8000	8000	6500	5000	5000	4200	4200	3150
Moment of inertia J kgm ²	0.007	0.018	0.04	0.12	0.3	0.3	0.82	0.82	2.5
Weight without jaws approx. kg	4.3	6.9	11.5	19.6	33	33	56.8	56.8	108.6
Actuating cylinders (recommended)	OVS-85/ SZS-37/70	OVS-85/ SZS-37/70	OVS-85/ SZS-46/103	OVS-85/ SZS-52/130	OVS-105/ SZS-77/170	OVS-105/ SZS-77/170	OVS-105/ SZS-95/225	OVS-105/ SZS-95/225	OVS-130/ SZS-127/325

DURO-A, 3-jaws, serration 60°

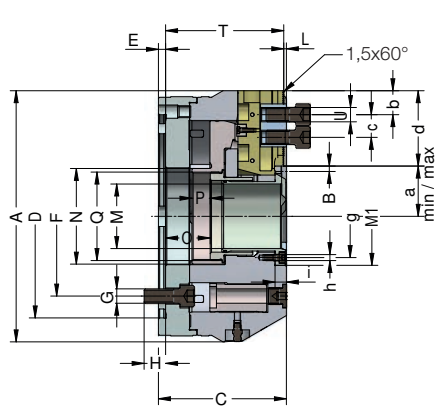

Size 110 to 210 with tightening thread

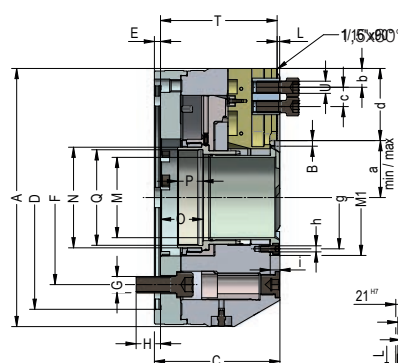
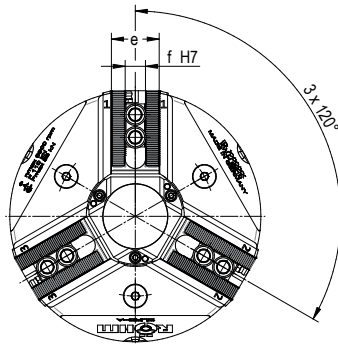

Size 254 to 400 with turnable ring

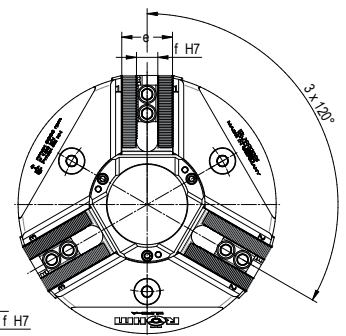
 offsetted T-nut
only in size 254

C 15

 3-jaw power chuck **DURO-A**, serration 60°, cylindrical centre mount, connection dimensions according to **DIN ISO 702-4**

Item No.	183722	183723	183724	183725	183726	183727	183728	183729	183730	183731
Size	110	135	165	210	254	254	315	315	400 (1,5x60°)	400 (3x60°)
Number of jaws	3	3	3	3	3	3	3	3	3	3
A mm	110	135	165	210	254	254	315	315	400	400
Jaw travel B mm	3.2	3.2	3.5	4.5	5.5	5.5	6.2	6.2	7.5	7.5
C mm	78	88	97	107	121	123.5	132.5	137	159.5	159.5
Mount D	ZA 60	ZA 115	ZA 140	ZA 170	ZA 170	ZA 220	ZA 220	ZA 300	ZA 380	ZA 380
E mm	6	6	6	6	6	6	6	6	6	6
F mm	82.6	82.6	104.8	133.4	133.4	171.4	171.4	235	330.2	330.2
G	3xM10	3xM10	3xM10	3xM12	3xM12	3xM16	3xM16	3xM20	3xM24	3xM24
H mm	15	15	15	18	18	24	26.5	30	30	30
Wedge stroke K mm	12	12	13	17	20.5	20.5	23	23	28	28
L mm	2.5	2.2	2.2	2.2	2.5	2.5	2.5	2.5	3.2	3.2
M max. mm	27	34	46	54	79	79	98.5	98.5	133	133
M ^{H7} mm	52	59	74	82	114	114	140	140	180.5	180.5
N mm	38	45	58	80	99	99	121	121	157.5	157.5
O min.	10.5	15.5	17.5	20.3	18.7	21.2	22.1	26.6	30.6	30.6
O max.	22.5	27.5	30.5	37.3	39.2	41.7	45.1	49.6	58.6	58.6
P mm	11.5	13.5	15.5	15.3	25	25	25	25	35	35
Q mm	M34x1.5	M38x1.5	M54x1.5	M74x1.5	M94x1.5	M94x1.5	M114x2	M114x2	M148x2	M148x2
T mm	71.3	79.3	88.8	98.8	112.3	114.8	121.8	126.3	144.3	144.3
U mm	M8	M8	M10	M12	M12	M12	M16	M16	M20	M20
a min.	21.8	25.3	31.5	37.5	50.5	50.5	61.3	61.3	79.5	79.5
a max.	25	28.5	35	42	56	56	67.5	67.5	87	87
b min.	2.5	5.0	-1	15.5	15.5	15.5	15.5	15.5	20	20
b max.	8.5	7.5	12	34.5	42	42	51	51	62	62
c mm	14	14	20	25	30	30	30	30	31	31
d mm	30	39	47.5	63	71	71	90	90	113	113
e mm	24	25	32	40	50	50	50	50	60	60
fH7-0.025 mm	10	10	12	14	16	16	21	21	25.5	25.5
g mm	43	48	61	69	101	101	125	125	166	166
h	M4	M4	M5	M5	M6	M6	M6	M6	M8	M8
i	6	6	7.5	9.5	9.5	9.5	11.5	11.5	20	20
Max. swing top jaws mm	136 (113 K)	170	195	260 (250 K)	305	305	402 (380 K)	402 (380 K)	520	520
Maximum draw bar pull kN	17	25	30	38	53	53	62	62	90	90
Max. total clamping force kN	48	70	86	110	150	150	180	180	250	250
Max. admissible speed min ⁻¹	8500	8000	8000	6500	5000	5000	4200	4200	3150	3150
Moment of inertia J kgm ²	0.007	0.018	0.04	0.12	0.3	0.3	0.82	0.82	2.5	2.5
Weight without jaws approx. kg	4.3	6.9	11.5	19.6	33	33	56.8	56.8	108.6	108.6
Actuating cylinders (recommended)	OVS-85/ SZS-37/70	OVS-85/ SZS-37/70	OVS-85/ SZS-46/103	OVS-85/ SZS-52/130	OVS-105/ SZS-77/170	OVS-105/ SZS-77/170	OVS-105/ SZS-95/225	OVS-105/ SZS-95/225	OVS-130/ SZS-127/325	OVS-130/ SZS-127/325

Jaws DURO-A

C 21

Reversible top jaws, hardened, serration 90° - material: 16MnCr5

Chuck Size	3-jaw set	Jaw length mm	Jaw height mm	Jaw width mm	Serration
110	149352	45	32	26	1/16"x 90°
135	046544	56	37.5	26	1/16"x 90°
165	046404	56	37.5	26	1/16"x 90°
165	351320	51.5	26	26	1/16"x 90°
210/254	118522	75	49	36	1/16"x 90°
315	046414	103.5	58	50	1/16"x 90°
400	037531	135	65	68	3/32"x 90°

Additionally or later applied, hardened jaws must be ground out in the chuck.

C 21

Reversible top jaws, 3-jaw set, hardened serration 60° - material: 16MnCr5

Chuck Size	3-jaw set	Jaw length mm	Jaw height mm	Jaw width mm	Serration
135	154814 ¹⁾	54	27,5	23	1,5 x 60°
165	154674 ¹⁾	66	36	34,7	1,5 x 60°
210	154676	81	49	36	1,5 x 60°
254	154678	99,5	54	44,5	1,5 x 60°
315	154816 ¹⁾	103	55,5	50	1,5 x 60°

¹⁾ One step only

Additionally or later applied, hardened jaws must be ground out in the chuck.

C 21

Soft top jaws, can be hardened, serration 90° - material: 16MnCr5

Chuck Size	3-jaw set	Jaw length mm	Jaw height mm	Jaw width mm	Serration
110	149353	45	38	26.5	1/16"x 90°
135	046402	53	30	22.5	1/16"x 90°
165	046403	55	38	26.5	1/16"x 90°
210	133152	66.7	53	36.5	1/16"x 90°
254	133153	75	53	36.5	1/16"x 90°
315	133154	95	54.5	45	1/16"x 90°
400	133156	130	80	50	3/32"x 90°

C 21

Soft top jaws, 3-jaw set, can be hardened serration 60° - material: 16MnCr5

Chuck Size	3-jaw set	Jaw length mm	Jaw height mm	Jaw width mm	Serration
135/165	154863	54	29	23	1,5 x 60°
170	154865	72	43	30,5	1,5 x 60°
210	154867	95	45,5	35	1,5 x 60°
254	154869	110	45	50	1,5 x 60°
315	154871	130	55,5	50	1,5 x 60°

C 21

Claw-type jaws, 1 piece, hardened, serration 90° - width of the groove 10

Item no.	Chuck Size	Jaw length mm	Jaw height mm	Claw length mm	Serration
149920	110	42	27	37.1	1/16"x 90°
149921	110	42	27	23.4	1/16"x 90°
149922	110	47	27	17.7	1/16"x 90°

C 21

Claw-type jaws, 1 piece, hardened, serration 90° - width of the groove 10

Item no.	Chuck Size	Jaw length mm	Jaw height mm	Claw length mm	Serration
147259	135	50	27	41	1/16"x 90°
147261	135	44	27	22	1/16"x 90°

Jaws DURO-A

C 21
Claw-type jaws, 1 piece, hardened, serration 90° - width of the groove 12



Item no.	Chuck Size	Jaw length mm	Jaw height mm	Claw length mm	Serration
144320	165	66	38	52	1/16"x 90°
144321	165	56	38	34	1/16"x 90°
144322	165	66	38	25	1/16"x 90°

C 21
Claw-type jaws, 1 piece, hardened, serration 90° - width of the groove 17



Item no.	Chuck Size	Jaw length mm	Jaw height mm	Claw length mm	Serration
137031	210/254	67	45	53	1/16"x 90°
137032	210/254	65	45	46	1/16"x 90°
137033	210/254	55	45	39	1/16"x 90°
137034	210/254	50	45	31	1/16"x 90°
137035	210/254	55	45	27	1/16"x 90°
137036	210/254	65	45	19	1/16"x 90°
137037	210/254	65	45	26	1/16"x 90°
137038	210/254	55	45	24	1/16"x 90°
137039	210/254	55	45	40	1/16"x 90°

C 21
Claw-type jaws, 1 piece, hardened, serration 90° - width of the groove 21



Item no.	Chuck Size	Jaw length mm	Jaw height mm	Claw length mm	Serration
137041	254/315	95	50	80	1/16"x 90°
137042	254/315	75	50	60	1/16"x 90°
137043	254/315	60	50	43	1/16"x 90°
137044	254/315	70	50	37	1/16"x 90°
137045	254/315	95	50	25	1/16"x 90°
137046	254/315	80	50	30	1/16"x 90°

C 21
Claw-type jaws, 1 piece, hardened, serration 90° - width of the groove 25.5



Item no.	Chuck Size	Jaw length mm	Jaw height mm	Claw length mm	Serration
137051	400	130	65	113	3/32"x 90°
137052	400	90	65	67	3/32"x 90°
137053	400	100	65	45	3/32"x 90°
137054	400	130	65	33	3/32"x 90°

C 21
Claw-type jaws, 1 piece, hardened serration 60° - width of the groove 12



Item no.	Chuck Size	Jaw length mm	Jaw height mm	Claw length mm	Serration
156025	165	67	45	53	1,5 x 60°
156027	165	65	45	46	1,5 x 60°
156029	165	55	45	40	1,5 x 60°
161189	165	55	45	24	1,5 x 60°

C 21
Claw-type jaws, 1 piece, hardened serration 60° - width of the groove 16



Item no.	Chuck Size	Jaw length mm	Jaw height mm	Claw length mm	Serration
156099	254	95	50	80	1,5 x 60°
156101	254	75	50	60	1,5 x 60°
156103	254	60	50	43	1,5 x 60°
156105	254	70	50	37	1,5 x 60°

Accessories DURO-A

C 15 Extended T-nuts With screw, for SV 1/16" x 90°

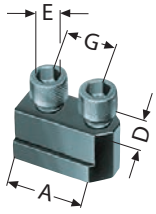

Item no.	Chuck Size	Contents of delivery	A mm	D mm	E	G mm
1305164 ▲	110	piece	30	10	M8x20	15
1305165	135	piece	34	10	M6x18	2x12
1305166	165	piece	42	12	M8x20	2x15
1305167	210	piece	36	17	M12x25	19
1305168	254	piece	36	17	M12x25	19
1305169	315	piece	46	21	M16x30	25
1305170	400	Piece	59	25.5	M20x40	31

A09 Special grease F80 for lathe chucks For lubrication and conservation of chucking power



Item no.	Design	Contents
308555	Cartridge (DIN 1284) Ø 53.5x235mm	0.5 kg
028975	Tin	1 kg

C15 Grease gun DIN1283



Item no.	Connection	Contents of delivery
329093	M10x1	150 mm nozzle tube bent, needlepoint mouthpiece, top mouthpiece, 300 mm high pressure hose with 4 jaw hydraulics cross mouthpiece

C 15 Intermediate adaptor plates with cylindrical centre mount DIN 6353 for 3-jaw chucks Mounting from front to ISO 702-1 (DIN 55026/55021) and ASA B 5.9 A1/A2 with metric mounting bolts

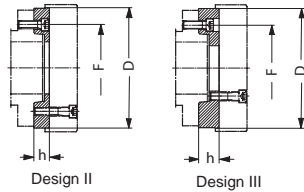

Item no.	Spindle nose size	Size	Design	h mm	F mm	D mm
174525 ¹⁾	4	110	II	25	82.6	60
174526 ¹⁾	4	135	II	18	82.6	115
145125 ¹⁾	4	165	II	18	82.6	140
174527	5	135	II	32	104.8	115
174528	5	165	II	21	104.8	140
145127	5	210	II	21	104.8	170
145129	6	165	II	35	133.4	140
174529	6	210	II	27	133.4	170
145131	6	254	II	27	133.4	220
145135	8	210	II	39	171.4	170
174530	8	254/315	II	39	171.4	220
145143	11	254	III	48	235	220
174531	11	315	II	36	235	300
145147	11	400	II	40	235	380
174532	15	400	II	50	330.2	380

¹⁾ DIN 55021 on request
All fastening parts are included
Intermediate adaptor plate for 2-jaw version on request

Jaw dimensions DURO-A

Reversible top jaws UB,
hardened, serration 90°,
material 16MnCr5

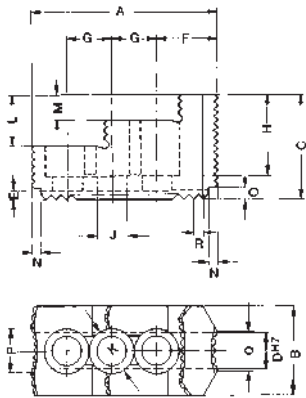

Chuck size	110	135	165	165	210/254	315	400/500
Type	543-21	537-02	538-02	543 1)	538-04	538-05	538-07
Item no. 3-jaw	149352	046544	046404	351320	118522	046414	037531
A	45	56	56	51.5	75	103.5	135
B	26	26	26	26	36	50	68
C	32	37.5	37.5	26	49	58	65
DH7	10	10	12	12	17	21	25.5
E	3.5	3.5	3.5	3.5	5	5	5
F	15	10	14	23	21.5	33.5	48
G	15	12 2)	15	15 3)	19	25	31
H	23	29	29	17	37.5	45	48
J	8.4	6.4	8.4	9	13	17	21
K	13.5	10.4	13.5	14	19	25	31
L	14	20	20	-	24	28	-
M	7	10	10	8	12	14	26
N	4	4	4	3	6	6	6.5
O	4	4	4	4	7.5	6.5	5.5
P	8	5	5	20	18	24.5	34
Q	5	5	5	3	7	22.5	40
R	1/16"x90°	1/16"x90°	1/16"x90°	1/16"x90°	1/16"x90°	1/16"x90°	3/32"x90°
Weight/jaw kg	0.155	0.130	0.170	0.150	0.460	1.130	2.000

1) One step only, for 8000 min⁻¹
2) 4 mounting holes

3) 2 mounting holes

Soft top jaws AB,
serration 90°,
material 16MnCr5

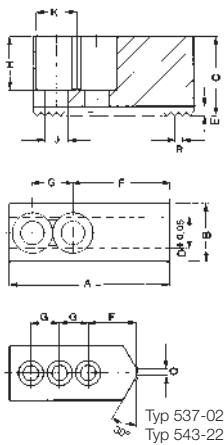

Chuck size	110	135	165	210	254	315	400
Type	543-22	537-02	538-02	538-03	538-04	538-05	538-07
Item no. 3-jaw	149353	046402	046403	133152	133153	133154	133156
A	45	53	55	66.7	75	95	130
B	26.5	22.5	26.5	36.5	36.5	45	50
C	38	30	38	53	53	54.5	80
D	10	10	12	17	17	21	25.5
E	3.5	3.5	3.5	5	5	5	5
F	15	20	31	36	44	55	79
G	15	12 1)	15	19	19	25	31
H	23	20	28	43	43	42.5	60
J	8.4	6.4	8.4	13	13	17	21
K	13.5	10.4	13.5	19	19	25	31
Q	5	3	-	-	-	-	-
R	1/16"x90°	1/16"x90°	1/16"x90°	1/16"x90°	1/16"x90°	1/16"x90°	3/32"x90°
Weight/jaw kg	0.210	0.223	0.320	0.700	0.880	1.400	3.100

1) 3 mounting holes

Jaw dimensions DURO-A

Reversible top jaws UB,
serration 60°,
material 16MnCr5

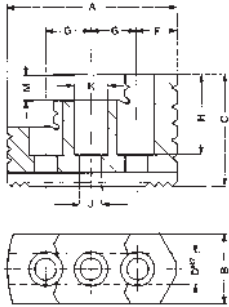

Chuck size	165	210	254	315
Type	543-31	543-31	543-31	543-31
Item no. 3-jaw	154674 1)	154676	154678	154816 1)
A	66	81	99,5	103
B	34,7	36	44,5	50
C	36	49	54	55,5
D	12	14	16	21
F	12,5	17,5	25,5	22,5
G	20	25	30	30
H	23	36,5	38,5	34
J	11	13	13	17
K	17	19	19	25
Serration	1,5 x 60°	1,5 x 60°	1,5 x 60°	1,5 x 60°
Weight/jaw kg	0,3	0,6	1,2	1,5

1) One step only

Soft top jaws AB,
can be hardened, serration 60°,
material 16MnCr5

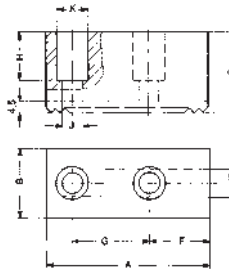

Chuck size	165	210	254	315
Type	543-32	543-32	543-32	543-32
Item no. 3-jaw	154865	154867	154869	154871
A	72	95	110	130
B	32,5	35	50	50
C	40	45,5	45	55,5
D	12	14	16	21
F	37	46	50	52
G	20	25	30	30
H	27	33	29	34
J	11	13	13	17
K	17	19	19	25
Serration	1,5 x 60°	1,5 x 60°	1,5 x 60°	1,5 x 60°
Weight/jaw kg	0,5	0,9	1,7	1,9

Chucking capacities DURO-A

Chucking capacities with reversible top jaws UB, for 3-jaw chucks

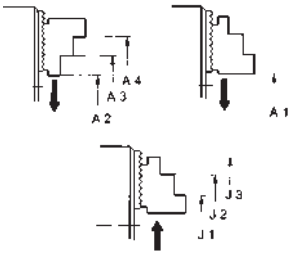

Chuck size		110	135	165	165*	210	210**	254	315	400
with reversible jaws	Type	543-21	527-02	538-02	543	538-04	543-09	538-04	538-05	538-07
	Jaw position									
External chucking	A1	6-46	5-68	6-67	4-52	12-98	4-70	22-144	25-169	30-203
	A2	-	-	-	21-73	26-112	-	40-156	45-196	47-250
	A3	41-76	52-115	53-118	-	82-165	-	94-210	127-280	-
	A4	68-106	87-150	88-165	94-146	132-218	112-170	146-262	209-360	245-453
Internal chucking	J1	42-80	35-100	36-99	32-84	61-144	60-126	76-192	76-216	96-280
	J2	70-108	70-135	71-134	-	110-198	-	128-244	150-348	-
	J3	96-135	117-182	118-181	102-157	162-248	-	182-298	230-380	277-478

* One step only

** One step only, extended

KFD-HS - low centrifugal force losses

2- and 3-jaw chuck, with large through-hole, for very high speeds

The construction principle of the power chuck KFD-HS consists of absorbing the centrifugal forces which occur during machining to the degree that the clamping force is hardly influenced. This occurs thanks to a special type of wedge hook connection. Even for extremely high speeds, the clamping force drop is very low. The high rigidity is achieved through the screw connection between the chuck body and chuck flange. Thus, this chuck type offers the optimal precondition for exactly machining shaft-type and flange-type workpieces.

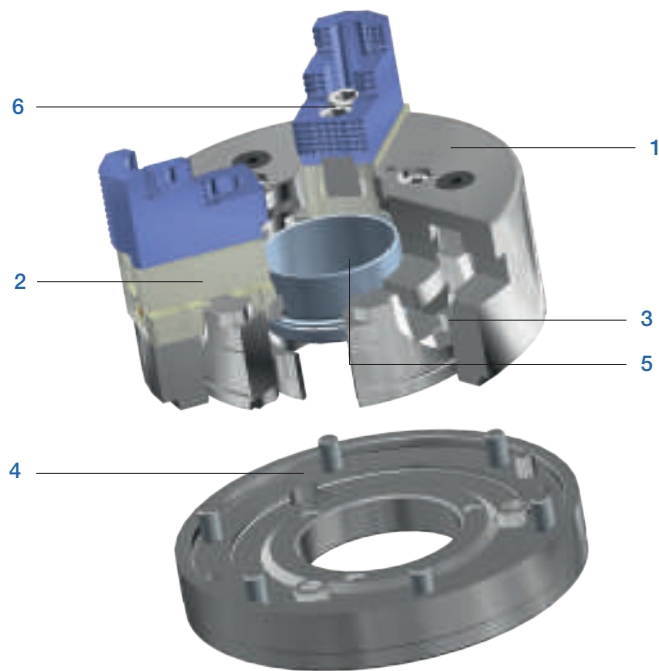

KFD-HS components

1. Body
2. Base jaw
3. Clamping piston
4. Chuck flange
5. Protective bushing
6. Slot nut

KFD-HE

Standard chuck for use on modern turning machines. A large through-hole allows both bar and pipe machining as well as the machining of flange-type workpieces. The power is transmitted via the proven wedge hook system.

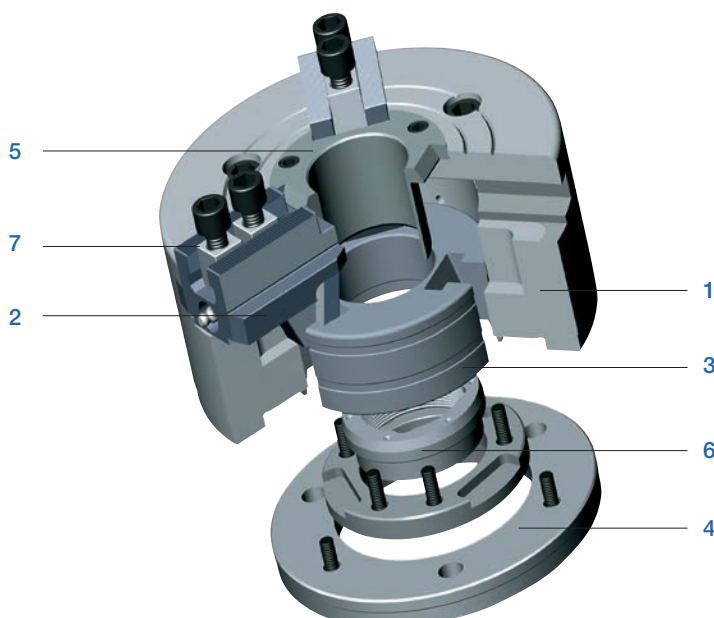

KFD-HE components

1. Body
2. Base jaw
3. Piston
4. Chuck flange
5. Protective bushing
6. Ring nut
7. Slot nut

KFD-HS - optimized centrifugal forces



APPLICATION

Premium power chucks with through-hole for maximum speeds and optimized centrifugal forces.

TYPE

Power chuck available with cylindrical centre mount or short taper mount. 3-jaw version with serration (90°) or tongue and groove. 2-jaw version with serration (90°).

CUSTOMER BENEFITS

- ⊕ Low centrifugal force losses and high speeds thanks to special wedge hook system with annular piston
- ⊕ Larger than average through-hole for wide range of workpieces
- ⊕ Maximum precision thanks to rigid chuck construction
- ⊕ If necessary quick conversion to a different spindle nose by simply exchanging the centering adapter

TECHNICAL FEATURES

- Universal construction of the piston connection (piston does not project into the spindle bore area, even with the piston position moved back)
- Long jaw guide
- Clamping inserts can be used for bar machining (special version)

Included in the scope of delivery:

Chuck, chuck and jaw mounting screws, mounting wrench, slot nuts (without top jaws)

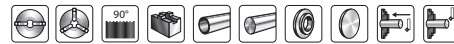

Gripping force/speed diagram (3-jaw chucks only)

The loss of gripping force was determined experimentally on a chuck with matched UB top jaws. It is largely independent of the initial gripping force at zero speed.

Upper curve: min. centrifugal force of top jaw



Lower curve: max. centrifugal force of top jaw



To obtain the specified gripping forces, the chuck must be in a perfect condition and lubricated with F 80 lubricant recommended by RÖHM. Measuring point near chuck face.

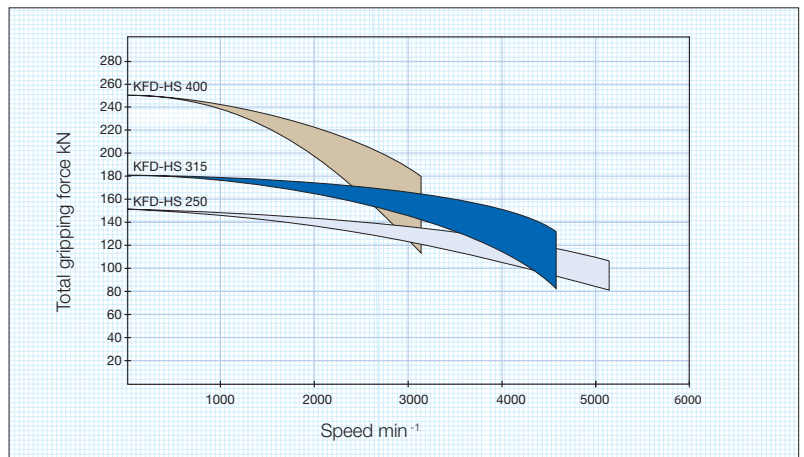
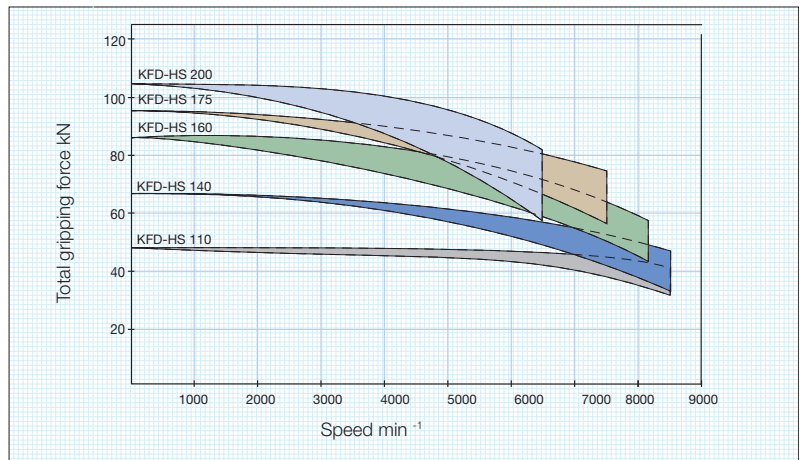

KFD-HS 3-jaw, serration 90°

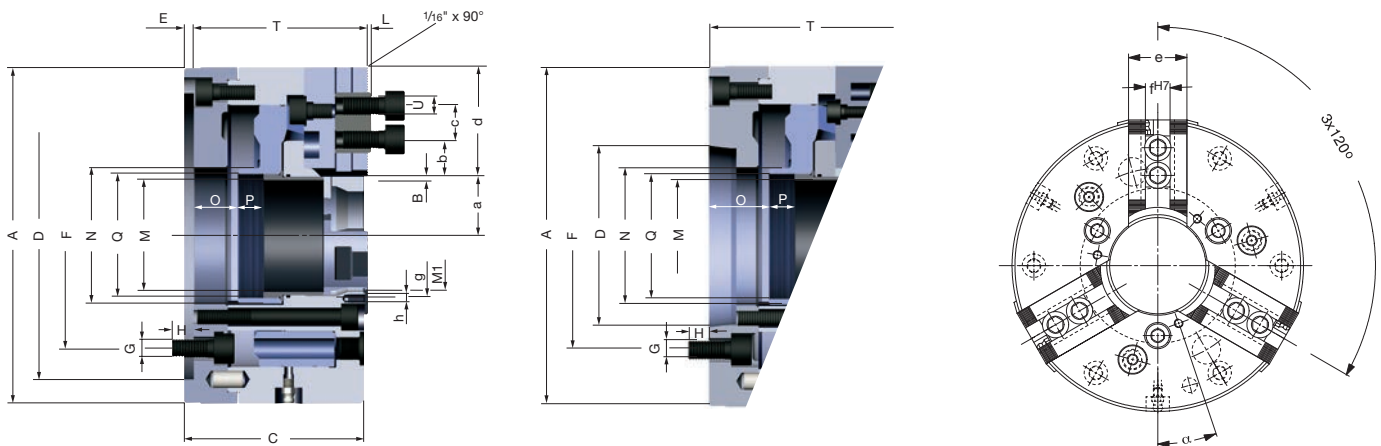

C 15

3-jaw power chuck KFD-HS, with tightening thread, serration 90°

 Cylindrical centre mount, connection dimensions in acc. with **DIN 6353** / short taper mount (KK) for **ISO 702-1** (DIN 55026/55021)

Item No.	149406	149405	144258	142690	143692	142478	144259 ▲	143893	143888	142479
Size	110	110	140	140	160	160	175	175	200	200
Number of jaws	3	3	3	3	3	3	3	3	3	3
A mm	110	110	140	140	160	160	175	175	200	200
Jaw travel B mm	3,2	3,2	3,2	3,2	4	4	4	4	5	5
C mm	78	86	88	92	102	108	102	108	107	112
Mount D	ZA 60	KK 4 ¹⁾	ZA 120	KK 5	ZA 140	KK 5	ZA 140	KK 5	ZA 170	KK 6
E mm	6	13	6	15	6	16	6	16	6	16
F mm	82,6	82,6	104,8	104,8	104,8	104,8	104,8	104,8	133,4	133,4
G	3xM10	3xM10	3xM10	3xM10	3xM10	3xM10	3xM10	3xM10	3xM12	3xM12
H mm	14	14	15	17	15	14	15	14	18	17
Wedge stroke K mm	12	12	12	12	15	15	15	15	18,5	18,5
L mm	2,5	2,5	2,5	2,5	2,5	2,5	2,5	2,5	2,5	2,5
M max. mm	26	26	37	37	46	46	56	56	66	66
M ₁ ^{H7} mm	32	32	37	37	46	46	56	56	66	66
N mm	38	38	48	48	58	58	68	68	80	80
O min.	-1	11	5	13	6	16	6	16	7,5	16,5
O max.	11	23	17	25	21	31	21	31	26	35
P mm	12	12	14	14	16	16	16	16	15	15
Q mm	M34x1,5	M34x1,5	M44x1,5	M44x1,5	M54x1,5	M54x1,5	M65x1,5	M65x1,5	M74x1,5	M74x1,5
T mm	80	84	84	90	98	106	98	106	103	110
U mm	M8	M8	M6	M6	M8	M8	M8	M8	M12	M12
a min.	10,8	10,8	16,8	16,8	24	24	29	29	35	35
a max.	14	14	20	20	28	28	33	33	40	40
b min.	3	3	0	0	0	0	0	0	8,5	8,5
b max.	23	23	26	26	22	22	24,5	24,5	32,5	32,5
c mm	15	15	2x12	2x12	2x15	2x15	2x15	2x15	19	19
d mm	41	41	50	50	52	52	54,5	54,5	60	60
e mm	24	24	25	25	32	32	32	32	40	40
fH7-0,025 mm	10	10	10	10	12	12	12	12	17	17
g mm	50	50	68	68	76	76	76	76	84	84
h	M5x8	M5x8	M5x8	M5x8	M6x10	M6x10	M6x10	M6x10	M6x10	M6x10
α	0°	0°	22° 30'	22° 30'	20°	20°	20°	20°	20°	20°
Max. swing top jaws mm	113	113	180	180	195	195	210	210	250	250
Maximum draw bar pull kN	18	18	25	25	35	35	40	40	48	48
Max. total clamping force kN	48	48	70	70	86	86	95	95	110	110
Max. admissible speed min ⁻¹	8500	8500	8000	8000	8000	8000	7000	7000	6500	6500
Moment of inertia J kgm ²	0,007	0,007	0,022	0,022	0,0415	0,0415	0,057	0,057	0,1	0,1
Weight without jaws approx. kg	5	5	9	9	12	12	15	15	20	20
Actuating cylinders (recommended)	OVS-85 / SZS-37/70	OVS-85 / SZS-37/70	OVS-105 / SZS-37/70	OVS-105 / SZS-37/70	OVS-105 / SZS-46/103	OVS-105 / SZS-46/103	OVS-105 / SZS-52/130	OVS-105 / SZS-52/130	OVS-130 / SZS-67/150	OVS-130 / SZS-67/150

¹⁾ ISO 702-1 (DIN 55026) only (DIN 55021 on request)

KFD-HS 3-jaw, serration 90°

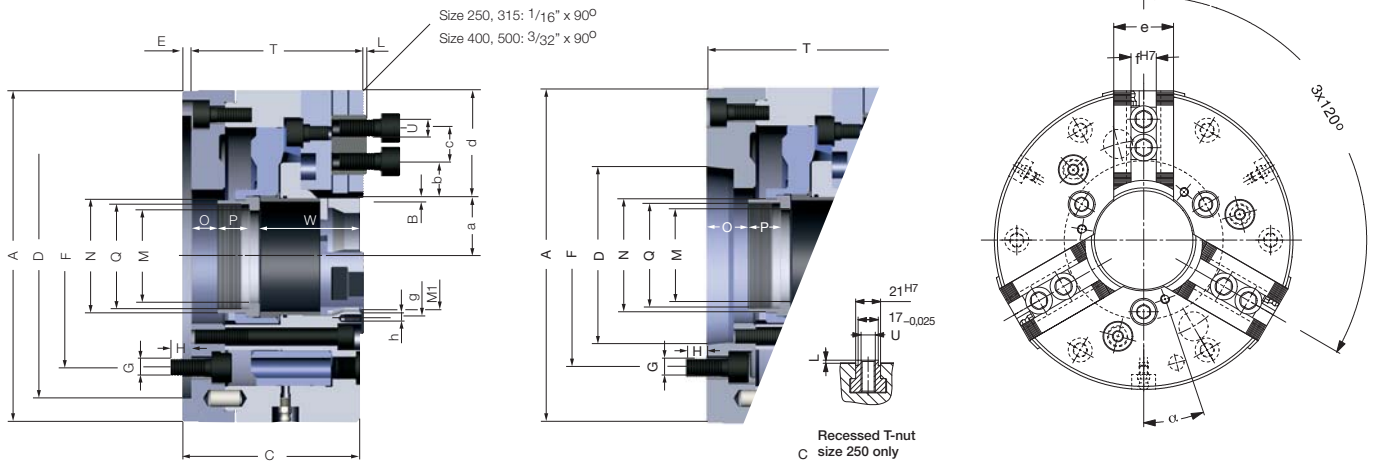

C 15
3-jaw power chuck KFD-HS, with tightening thread, serration 90°
 Cylindrical centre mount, connection dimensions in acc. with **DIN 6353** / short taper mount (KK) for **ISO 702-1** (DIN 55026/55021)

Item No.	161725 ▲	144260	143726 ▲	142691	144261 ▲	143748 ▲	144262 ▲	143749 ▲	144263 ▲	143750	143751
Size	250	250	250	250	315	315	315	315	400	400	400
Number of jaws	3	3	3	3	3	3	3	3	3	3	3
A mm	250	250	250	250	315	315	315	315	400	400	400
Jaw travel B mm	6,2	6,2	6,2	6,2	6,2	6,2	6,2	6,2	7,5	7,5	7,5
C mm	128	128	130	130	128	130	139	143	156	156	156
Mount D	ZA 170	ZA 220	KK 6	KK 8	ZA 220	KK 8	ZA 300	KK 11	ZA 380	KK 11	KK 15
E mm	6	6	15	19	6	19	6	21	6	18	21
F mm	133,4	171,4	133,4	171,4	171,4	171,4	235	235	330,2	235	330,2
G	3xM12	3xM16	3xM12	3xM16	3xM16	3xM16	3xM20	3xM20	3xM24	3xM20	3xM24
H mm	16	24	18	24	24	24	30	30	30	30	30
Wedge stroke K mm	23	23	23	23	23	23	23	23	28	28	28
L mm	2,5	2,5	2,5	2,5	2,5	2,5	2,5	2,5	3,5	3,5	3,5
M max. mm	66	86	66	86	86	86	108	108	165	126	165
M _t ^{H7} mm	94	94	94	94	94	94	115	115	172	172	172
N mm	110	99	80	99	99	99	126	126	180	142	180
O min.	0	-6	2	2	-6	2	-9	1	-12	0	-6
O max.	23	17	25	25	17	25	14	24	16	28	22
P mm	19	25	25	25	25	25	25	25	35	35	35
Q mm	M74x1,5	M94x1,5	M74x1,5	M94x1,5	M94x1,5	M94x1,5	M120x1,5	M120x1,5	M172x3	M132x1,5	M172x3
T mm	124	124	132	132	124	132	135	145	153	159	159
U mm	M12	M12	M12	M12	M16	M16	M16	M16	M20	M20	M20
W mm	74	74	74	74	74	74	85	85	88	88	88
a min.	43,8	43,8	43,8	43,8	43,8	43,8	54,8	54,8	80,5	80,5	80,5
a max.	50	50	50	50	50	50	61	61	88	88	88
b min.	6	6	6	6	10,5	10,5	10,5	10,5	14,5	14,5	14,5
b max.	47,5	47,5	47,5	47,5	72	72	61	61	66,5	66,5	66,5
c mm	19	19	19	19	25	25	25	25	31	31	31
d mm	75	75	75	75	107,5	107,5	96,5	96,5	112	112	112
e mm	50	50	50	50	50	50	50	50	60	60	60
fH7-0,025 mm	17	17	17	17	21	21	21	21	25,5	25,5	25,5
g mm	108	108	108	108	108	108	136	136	190	190	190
h	M6x10	M6x10	M6x10	M6x10	M6x10	M6x10	M8x12	M8x12	M8x12	M8x12	M8x12
α	15°	0°	15°	0°	0°	0°	0°	0°	15°	15°	15°
Max. swing top jaws mm	305	305	305	305	380	380	380	380	520	520	520
Maximum draw bar pull kN	65	65	65	65	80	80	80	80	110	110	110
Max. total clamping force kN	150	150	150	150	180	180	180	180	250	250	250
Max. admissible speed min ⁻¹	5000	5000	5000	5000	4200	4200	4200	4200	3150	3150	3150
Moment of inertia J kgm ²	0,35	0,35	0,35	0,35	0,74	0,74	0,74	0,74	2,4	2,4	2,4
Weight without jaws approx. kg	40	40	40	40	56	56	56	56	120	120	120
Actuating cylinders (recommended)	OVS-150 / SZS-67/150	OVS-150 / SZS-86/200	OVS-150 / SZS-67/150	OVS-200 / SZS-86/200	OVS-200 / SZS-86/200	OVS-200 / SZS-86/200	OVS-200 / SZS-110/250	OVS-200 / SZS-110/250	OVS 200 / -	OVS-200 / SZS-127/325	OVS-200 / -

¹⁾ ISO 702-1 (DIN 55026) only (DIN 55021 on request)

Power chuck with through-hole KFD-HS

KFD-HS 3-jaw, tongue and groove

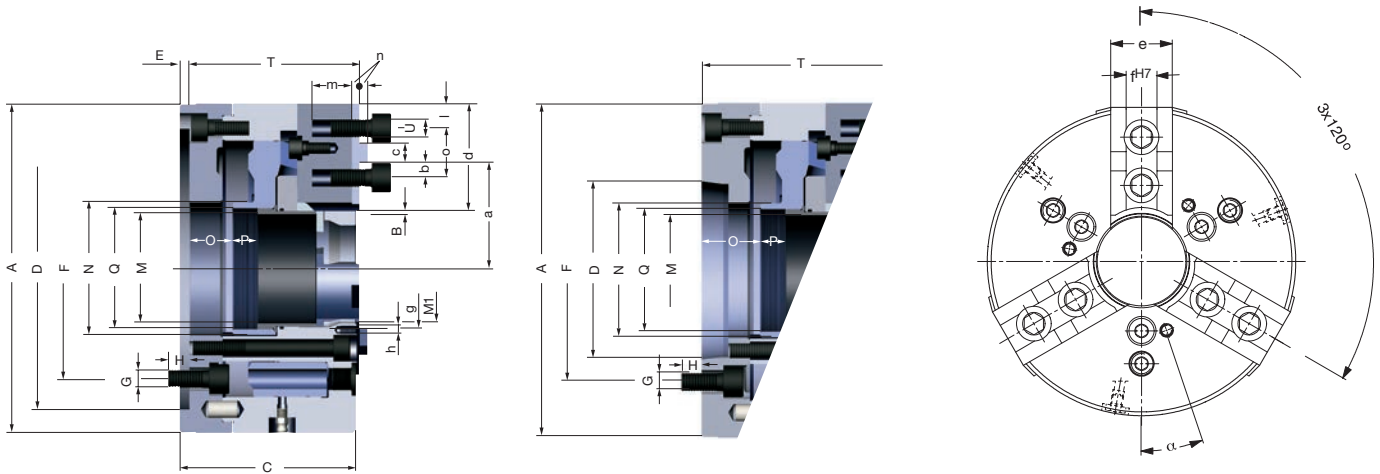

C15

3-jaw power chuck KFD-HS, with tightening thread, with tongue and groove

 Cylindrical centre mount, connection dimensions in acc. with **DIN 6353** / short taper mount (KK) for **ISO 702-1** (DIN 55026/55021)

Item No.	149846	149543	151532 ▲	156580 ▲	153182	157768	154239 ▲	155099
Size	110	110	140	140	160	160	200	200
Number of jaws	3	3	3	3	3	3	3	3
A mm	110	110	140	140	160	160	200	200
Jaw travel B mm	3,2	3,2	3,2	3,2	4	4	5	5
C mm	80	86	88	92	102	108	107	112
Mount D	ZA 60	KK 4 ¹⁾	ZA 120	KK 5	ZA 140	KK 5	ZA 170	KK 6
E mm	6	13	6	16	6	15	6	16
F mm	82,6	82,6	104,8	104,8	104,8	104,8	133,4	133,4
G	3xM10	3xM10	3xM10	3xM10	3xM10	3xM10	3xM12	3xM12
H mm	14	14	15	17	15	14	18	17
Wedge stroke K mm	12	12	12	12	15	15	18,5	18,5
M max. mm	26	26	37	37	46	46	66	66
M ₁ ^{H7} mm	32	32	37	37	46	46	66	66
N mm	38	38	48	48	58	58	80	80
O min.	-1	11	5	13	6	16	7,5	16,5
O max.	11	23	17	25	21	31	26	35
P mm	12	12	14	14	16	16	15	15
Q mm	M34x1,5	M34x1,5	M44x1,5	M44x1,5	M54x1,5	M54x1,5	M74x1,5	M74x1,5
T mm	78	80	84	90	98	106	103	110
U mm	M8	M8	M12	M12	M12	M12	M12	M12
a min.	31,8	31,8	45,3	45,3	43	43	59	59
a max.	35	35	48,5	48,5	47	47	64	64
c mm	10	10	13	13	10	10	12	12
d mm	30	30	50	50	56	56	65	65
e mm	24	24	25	25	32	32	40	40
fH7-0,025 mm	10	10	8	8	16	16	16	16
g mm	50	50	68	68	76	76	84	84
h	M5x8	M5x8	M5x8	M5x8	M6x10	M6x10	M6x10	M6x10
l mm	6,5	6,5	29	29	15,5	15,5	15	15
m mm	11	11	19	19	18	18	20	20
n mm	3	3	3	3	5	5	5	5
α	0°	0°	22° 30'	22° 30'	20°	20°	20°	20°
Max. swing top jaws mm	113	113	180	180	170	170	210	210
Maximum draw bar pull kN	18	18	25	25	35	35	48	48
Max. total clamping force kN	48	48	70	70	86	86	110	110
Max. admissible speed min ⁻¹	8500	8500	8000	8000	8000	8000	6500	6500
Moment of inertia J kgm ²	0,007	0,007	0,022	0,022	0,0415	0,0415	0,1	0,1
Weight without jaws approx. kg	5	5	9	9	12	12	20	20
Actuating cylinders (recommended)	OVS-85 / SZS-37/70	OVS-85 / SZS-37/70	OVS-105 / SZS-37/70	OVS-105 / SZS-37/70	OVS-105 / SZS-46/103	OVS-105 / SZS-46/103	OVS-130 / SZS-67/150	OVS-130 / SZS-67/150

* ISO 702-1 (DIN 55026) only (DIN 55021 on request)

KFD-HS 2-jaw, serration 90°

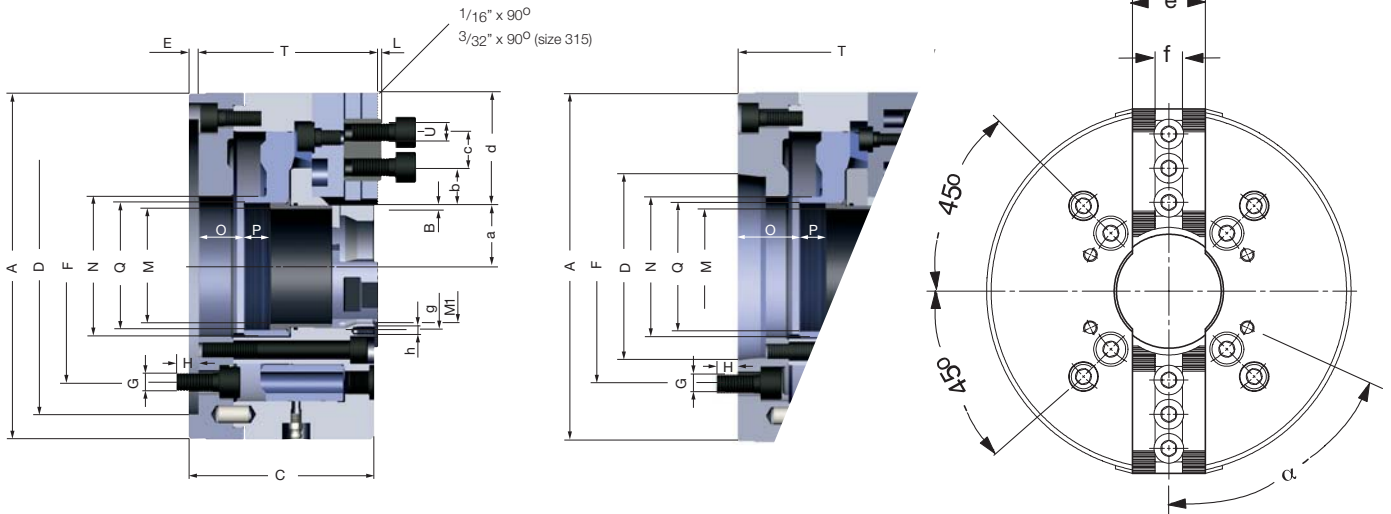

C15
2-jaw power chuck KFD-HS, with tightening thread, serration 90°
 Cylindrical centre mount, connection dimensions in acc. with **DIN 6353** / short taper mount (KK) for **ISO 702-1** (DIN 55026/55021)

Item No.	147281 ▲	147282 ▲	147285	147286	148036	148023	148031	162995
Size	160	160	200	200	250	250	250	315
Number of jaws	2	2	2	2	2	2	2	2
A mm	160	160	200	200	250	250	250	315
Jaw travel B mm	4	4	5	5	6,2	6,2	6,2	6,25
C mm	102	108	107	112	128	132	132	139
Mount D	ZA 140	KK 5	ZA 170	KK 6	ZA 220	KK 6	KK 8	ZA 300
E mm	6	15	6	16	6	15	19	6
F mm	104,8	104,8	133,4	133,4	171,4	133,4	171,4	235
G	4xM10	4xM10	4xM12	4xM12	4xM16	4xM12	4xM16	4xM20
H mm	15	14	18	17	24	18	24	30
Wedge stroke K mm	15	15	18,5	18,5	23	23	23	23
L mm	2,5	2,5	2,5	2,5	2,5	2,5	2,5	3,5
M max. mm	46	46	66	66	86	66	86	108
M _i ^{H7} mm	46	46	66	66	94	94	94	115
N mm	58	58	80	80	99	80	99	126
O min.	6	16	7,5	16,5	-6	2	2	-9
O max.	21	31	26	35	17	25	25	14
P mm	16	16	15	15	25	25	25	25
Q mm	M54x1,5	M54x1,5	M74x1,5	M74x1,5	M94x1,5	M74x1,5	M94x1,5	M120x1,5
T mm	98	106	103	110	124	130	130	135
U mm	M8	M8	M 12	M12	M12	M12	M12	M16
W mm	-	-	-	-	-	74	74	85
a min.	24	24	35	35	43,8	43,8	43,8	54,8
a max.	28	28	40	40	50	50	50	61
b min.	0	0	8,5	8,5	6	6	6	10,5
b max.	22	22	32,5	32,5	47,5	47,5	47,5	61
c mm	2x15	2x15	19	19	19	19	19	25
d mm	52	52	60	60	75	75	75	96,5
e mm	32	32	40	40	50	50	50	50
fH7-0,025 mm	12	12	17	17	17	17	17	21
g mm	76	76	84	84	108	108	108	136
h	M6x10	M6x10	M6x10	M6x10	M6x10	M6x10	M6x10	M8x12
α	40°	40°	60°	60°	60°	60°	60°	60°
Max. swing top jaws mm	170	170	250	250	305	305	305	380
Maximum draw bar pull kN	20	20	30	30	42	42	42	55
Max. total clamping force kN	45	45	66	66	94	94	94	120
Max. admissible speed min ⁻¹	8000	8000	6500	6500	5000	5000	5000	4200
Moment of inertia J kgm ²	0,0415	0,0415	0,1	0,1	0,35	0,35	0,35	0,62
Weight without jaws approx. kg	12	12	20	20	40	40	40	60
Actuating cylinders (recommended)	OVS-105 / SZS-46/103	OVS-105 / SZS-46/103	OVS-130 / SZS-67/150	OVS-130 / SZS-67/150	OVS-150 / SZS-67/150	OVS-150 / SZS-67/150	OVS-150 / SZS-86/200	OVS-200 / SZS-110/250

Other sizes on request

Power chuck with through-hole KFD-HS

Jaws KFD-HS

C 21
Reversible top jaws, hardened serration 90° - material: 16MnCr5



Chuck Size	2-jaw set	3-jaw set	Jaw length mm	Jaw height mm	Jaw width mm	Serration
110	-	149352	45	32	26	1/16"x 90°
140	046545	046544	56	37,5	26	1/16"x 90°
160/175	045796	046404	56	37,5	26	1/16"x 90°
160/175	-	351320	51,5	26	26	1/16"x 90°
200/250	118521	118522	75	49	36	1/16"x 90°
315	046435	046414	103,5	58	50	1/16"x 90°
400	046447	037531	135	65	68	3/32"x 90°

Additionally or later applied, hardened jaws must be ground out in the chuck

C 21
Soft top jaws, can be hardened serration 90° - material: 16MnCr5



Chuck Size	2-jaw set	3-jaw set	Jaw length mm	Jaw height mm	Jaw width mm	Serration
110	-	149353	45	38	26,5	1/16"x 90°
140	045794	046402	53	30	22,5	1/16"x 90°
160/175	045795	046403	55	38	26,5	1/16"x 90°
200	133147	133152	66,7	53	36,5	1/16"x 90°
250	133148	133153	75	53	36,5	1/16"x 90°
315	133149	133154	95	54,5	45	1/16"x 90°
400	133151	133156	130	80	50	3/32"x 90°

C 21
Soft top jaws, 3-jaw set, can be hardened tongue and groove, 120° bevelled, material: 16MnCr5



Chuck Size	3-jaw set	Jaw length mm	Jaw height mm	Jaw width mm
110	144082	53	30	22,5
140	123355	58	38	26,5
160	123358	72,7	53	36,5
200	123430	90,3	53	36,5

C 21
Claw-type jaws, 1 piece, hardened serration 90° - width of the groove 10



Item no.	Chuck Size	Jaw length mm	Jaw height mm	Claw length mm	Serration
149920	110	42	27	37,1	1/16"x 90°
149921	110	42	27	23,4	1/16"x 90°
149922	110	47	27	17,7	1/16"x 90°

C 21
Claw-type jaws, 1 piece, hardened serration 90° - width of the groove 10



Item no.	Chuck Size	Jaw length mm	Jaw height mm	Claw length mm	Serration
147259	140	50	27	41	1/16"x 90°
147261	140	44	27	22	1/16"x 90°

Jaws KFD-HS

C 21

Claw-type jaws, 1 piece, hardened serration 90° - width of the groove 12



Item no.	Chuck Size	Jaw length mm	Jaw height mm	Claw length mm	Serration
144320	160/175	66	38	52	1/16"x 90°
144321	160/175	56	38	34	1/16"x 90°
144322	160/175	66	38	25	1/16"x 90°

C 21

Claw-type jaws, 1 piece, hardened serration 90° - width of the groove 17



Item no.	Chuck Size	Jaw length mm	Jaw height mm	Claw length mm	Serration
137031	200/250	67	45	53	1/16"x 90°
137032	200/250	65	45	46	1/16"x 90°
137033	200/250	55	45	39	1/16"x 90°
137034	200/250	50	45	31	1/16"x 90°
137035	200/250	55	45	27	1/16"x 90°
137036	200/250	65	45	19	1/16"x 90°
137037	200/250	65	45	26	1/16"x 90°
137038	200/250	55	45	24	1/16"x 90°
137039	200/250	55	45	40	1/16"x 90°

C 21

Claw-type jaws, 1 piece, hardened serration 90° - width of the groove 21



Item no.	Chuck Size	Jaw length mm	Jaw height mm	Claw length mm	Serration
137041	250/315	95	50	80	1/16"x 90°
137042	250/315	75	50	60	1/16"x 90°
137043	250/315	60	50	43	1/16"x 90°
137044	250/315	70	50	37	1/16"x 90°
137045	250/315	95	50	25	1/16"x 90°
137046	250/315	80	50	30	1/16"x 90°

C 21

Claw-type jaws, 1 piece, hardened serration 90° - width of the groove 25,5



Item no.	Chuck Size	Jaw length mm	Jaw height mm	Claw length mm	Serration
137051	400	130	65	113	3/32"x 90°
137052	400	90	65	67	3/32"x 90°
137053	400	100	65	45	3/32"x 90°
137054	400	130	65	33	3/32"x 90°

Accessories KFD-HS

C 15 Extended T-nuts
With screw

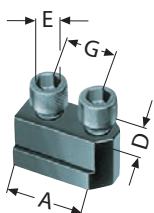

Item no.	Chuck Size	Contents of delivery	A mm	D mm	E	G mm
1305164▲	110	piece	30	10	M8x20	15
1305165	140	piece	34	10	M6x18	2x12
1305166	160/175	piece	42	12	M8x20	2x15
1305167	200	piece	36	17	M12x25	19
1305168	250	piece	36	17	M12x25	19
1305169	315	piece	46	21	M16x30	25
1305170	400	piece	59	25,5	M20x40	31

A09 Special grease F80 for lathe chucks
For lubrication and conservation of chucking power



Item no.	Design	Contents
308555	Cartridge (DIN 1284) Ø 53.5x235mm	0,5 kg
028975	Tin	1 kg

C15 Grease gun DIN1283



Item no.	Connection	Contents of delivery
329093	M10x1	150 mm nozzle tube bent, needlepoint mouthpiece, top mouthpiece, 300 mm high pressure hose with 4 jaw hydraulics cross mouthpiece

Accessories KFD-HS

C 15

Intermediate adaptor plates with cylindrical centre mount DIN 6353 for 3-jaw chucks

Mounting from front to ISO 702-1 (DIN 55026/55021) and ASA B 5.9 A1/A2 with metric mounting bolts

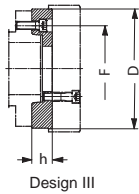
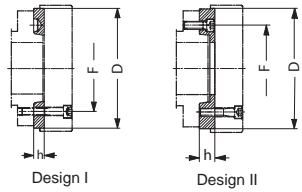

Item no.	Spindle nose size	Size	Design	h mm	F mm	D mm
145125 ¹⁾	4	160	II	18	82,6	140
145153	5	175	I	15	104,8	140
145127	5	200	II	21	104,8	170
145129	6	160	III	35	133,4	140
145297	6	175	III	35	133,4	140
145155	6	200	I	16	133,4	170
145131	6	250	II	27	133,4	220
145135	8	200	III	39	171,4	170
145157	8	250	I	18	171,4	220
145139▲	8	315	II	38	171,4	300
145143▲	11	250	III	48	235	220
145159	11	315	I	19	235	300
145147	11	400	II	40	235	380
145161	15	400/500/630	I	21	330,2	380

¹⁾ DIN 55021 on request

All fastening parts are included

Intermediate adaptor plate for 2-jaw version on request

Jaw dimensions KFD-HS

Reversible top jaws UB,
hardened, serration 90°,
material 16MnCr5

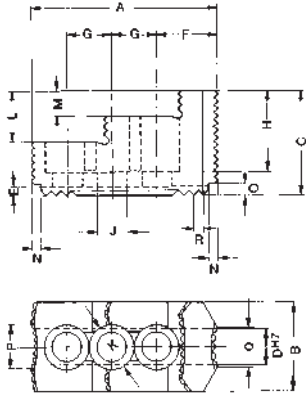

Chuck size	110	140	160/175	160	200/250	315	400/500
Type	543-21	537-02	538-02	543 1)	538-04	538-05	538-07
Item no. 2-jaw	-	046545	045796	-	118521	046435	046447
Item no. 3-jaw	149352	046544	046404	351320	118522	046414	037531
A	45	56	56	51,5	75	103,5	135
B	26	26	26	26	36	50	68
C	32	37,5	37,5	26	49	58	65
DH7	10	10	12	12	17	21	25,5
E	3,5	3,5	3,5	3,5	5	5	5
F	15	10	14	23	21,5	33,5	48
G	15	12 2)	15	15 3)	19	25	31
H	23	29	29	17	37,5	45	48
J	8,4	6,4	8,4	9	13	17	21
K	13,5	10,4	13,5	14	19	25	31
L	14	20	20	-	24	28	-
M	7	10	10	8	12	14	26
N	4	4	4	3	6	6	6,5
O	4	4	4	4	7,5	6,5	5,5
P	8	5	5	20	18	24,5	34
Q	5	5	5	3	7	22,5	40
R	1/16"x90°	1/16"x90°	1/16"x90°	1/16"x90°	1/16"x90°	1/16"x90°	3/32"x90°
Weight/jaw kg	0,155	0,130	0,170	0,150	0,460	1,130	2,000

1) One step only, for 8000 min⁻¹
2) 4 mounting holes

3) 2 mounting holes

Soft top jaws AB,
serration 90°,
material 16MnCr5

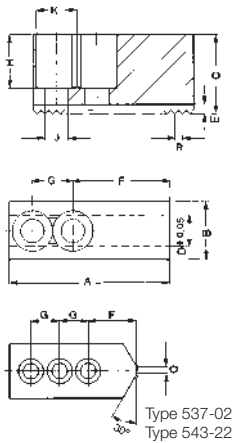

Chuck size	110	140	160/175	200	250	315	400/500
Type	543-22	537-02	538-02	538-03	538-04	538-05	538-07
Item no. 2-jaw	-	045794	045795	133147	133148	133149	133151
Item no. 3-jaw	149353	046402	046403	133152	133153	133154	133156
A	45	53	55	66,7	75	95	130
B	26,5	22,5	26,5	36,5	36,5	45	50
C	38	30	38	53	53	54,5	80
D	10	10	12	17	17	21	25,5
E	3,5	3,5	3,5	5	5	5	5
F	15	20	31	36	44	55	79
G	15	12 1)	15	19	19	25	31
H	23	20	28	43	43	42,5	60
J	8,4	6,4	8,4	13	13	17	21
K	13,5	10,4	13,5	19	19	25	31
Q	5	3	-	-	-	-	-
R	1/16"x90°	1/16"x90°	1/16"x90°	1/16"x90°	1/16"x90°	1/16"x90°	3/32"x90°
Weight/jaw kg	0,210	0,223	0,320	0,700	0,880	1,400	3,100

1) 3 mounting holes

Soft top jaws AB,
with tongue and groove,
material 16MnCr5

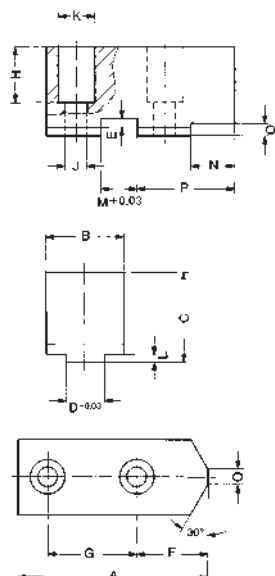

Chuck size	110	140	160	200
Type	549-10	538-22	538-13	538-14
Item no. 3-jaw	144082	123355	123358	123430
A	53	58	72,7	90,3
B	22,5	26,5	36,5	36,5
C	30	38	53	53
D _{-0,03}	10	8	16	16
E	3,5	3,5	5,5	5,5
F	26,5	31,5	32,2	45,3
G	17	-	25	30
H	20	25	38	38
J	9	13	13	13
K	15	19	19	19
L	2,5	2,5	4,5	4,5
M _{+0,03}	10	13	10	12
N	20	23	24,7	35,3
O	4	3	5	5
P	30	39,5	39,7	54,3
Q	3	3	3	6
Weight/jaw kg	0,21	0,46	0,720	1,0

Jaw dimensions KFD-HS

Claw type jaws KB
serration 90°

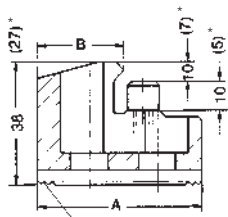

* KFD-HS 110+130+140

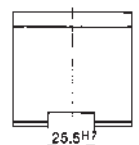
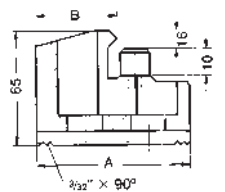
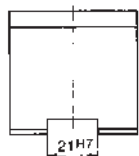
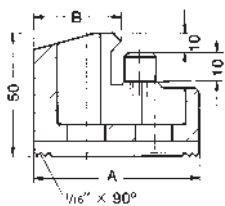
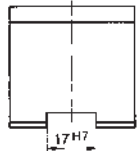
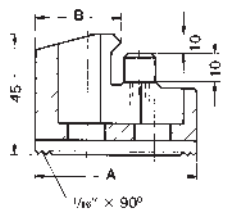
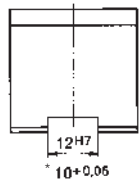

Piece	A	B	H	KFD-HS 110 External chucking	Piece	A	B	KFD-HS 140 External chucking
Item no.					Item no.			
149920	42	37,1	27	20-49	147259	50	41	27-67/35-72
149921	42	23,4	27	47-70	147261	44	22	58-108/61-114
149922	47	17,7	27	68-100				

Piece	A	B	H	KFD-HS 110 Internal chucking	Piece	A	B	KFD-HS 140 Internal chucking
Item no.					Item no.			
149922	47	17,7	27	45-75	147261	44	22	58-108/61-114
149921	42	23,4	27	56-102	147259	50	41	100-130/106-140
149920	42	37,1	27	84-130				

Piece	A	B	KFD-HS 160 External chucking	KFD-HS 175 External chucking
Item no.				
144320	66	52	38-84	48-100
144321	56	34	78-122	88-140
144322	66	25	120-146	130-160

Piece	A	B	KFD-HS 160 Internal chucking	KFD-HS 175 Internal chucking
Item no.				
144322	66	25	70-100	70-115
144321	56	34	92-140	102-155
144320	66	52	122-180	132-195

Piece	A	B	KFD-HS 200 External chucking	KFD-HS 250 External chucking
Item no.				
137031	67	53	55-110	68-162
137032	65	46	68-124	80-173
137039	55	40	95-150	108-200
137034	50	31	102-158	115-206
137035	55	27	110-168	125-220

Piece	A	B	KFD-HS 200 Internal chucking	KFD-HS 250 Internal chucking
Item no.				
137036	65	19	65-125	80-172
137037	65	26	86-142	100-192
137038	55	24	100-156	112-206
137035	55	27	120-178	135-228
137034	50	31	132-188	145-236
137039	55	40	136-195	150-245
137033	55	39	150-207	165-257
137032	65	46	164-222	179-270

Piece	A	B	KFD-HS 315 (86) ¹⁾ External chucking	KFD-HS 315 (108) ¹⁾ External chucking
Item no.				
137041	95	80	46-175	65-175
137042	75	60	92-220	104-220
137043	60	43	114-250	135-250
137044	70	37	142-275	166-275

Piece	A	B	KFD-HS 315 (86) ¹⁾ Internal chucking	KFD-HS 315 (108) ¹⁾ Internal chucking
Item no.				
137045	95	25	65-200	82-200
137046	80	30	108-242	130-242
137044	70	37	142-275	164-275
137043	60	43	170-305	195-305
137042	75	60	202-340	224-340

Piece	A	B	KFD-HS 400 External chucking	KFD-HS 400 (165) ¹⁾ External chucking
Item no.				
137051	130	113	70-270	94-270
137052	90	67	150-304	183-304
137053	100	45	175-390	210-390

Piece	A	B	KFD-HS 400 Internal chucking	KFD-HS 400 (165) ¹⁾ Internal chucking
Item no.				
137054	130	33	96-290	110-290
137053	100	45	160-305	195-305
137051	130	113	280-490	302-490

¹⁾ Chuck through-hole M

Chucking capacities KFD-HS

Chucking capacities with reversible top jaws UB, for 3-jaw chucks

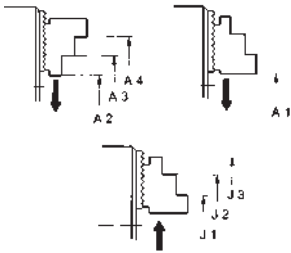

Chuck size		110	140	160	160*	175	200	200**	250	315	400
with reversible jaws	Type	543-21	527-02	538-02	543	538-02	538-04	543-09	538-04	538-05	538-07
	Jaw position										
External chucking	A1	6-46	5-68	6-67	4-52	6-82	12-98	4-70	22-144	25-169	30-203
	A2	-	-	-	21-73	-	26-112	-	40-156	45-196	47-250
	A3	41-76	52-115	53-118	-	54-133	82-165	-	94-210	127-280	-
	A4	68-106	87-150	88-165	94-146	90-180	132-218	112-170	146-262	209-360	245-453
Internal chucking	J1	42-80	35-100	36-99	32-84	36-114	61-144	60-126	76-192	76-216	96-280
	J2	70-108	70-135	71-134	-	71-149	110-198	-	128-244	150-348	-
	J3	96-135	117-182	118-181	102-157	118-196	162-248	-	182-298	230-380	277-478

* One step only

** One step only, extended

KFD-HE



APPLICATION

Standard power chuck with through-hole for bar and tube machining, as well as for flange-type workpieces.

TYPE

Standard version with cylindrical centre mount.

3-jaw version with serration 90° and 60°.

Universal draw tube adapter at serration 60°.

CUSTOMER BENEFITS

- ② Large through-hole for hollow or partially hollow clamping
- ② Long-tested chuck principle for maximum service life

TECHNICAL FEATURES

- Power transmission by means of wedge hook principle
- Direct lubrication of all wear surfaces
- Sturdy chuck construction

Included in the scope of delivery:

Chuck, chuck and jaw mounting screws, mounting wrench, slot nuts (without top jaws)

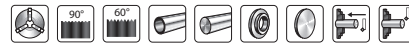

Gripping force/speed diagram

The loss of gripping force was determined experimentally on a chuck with matched UB top jaws. It is largely independent of the initial gripping force at zero speed.

Upper curve:
min. centrifugal
force of top jaw



Lower curve:
max. centrifugal
force of top jaw



To obtain the specified gripping forces, the chuck must be in a perfect condition and lubricated with F 80 lubricant recommended by RÖHM. Measuring point near chuck face.

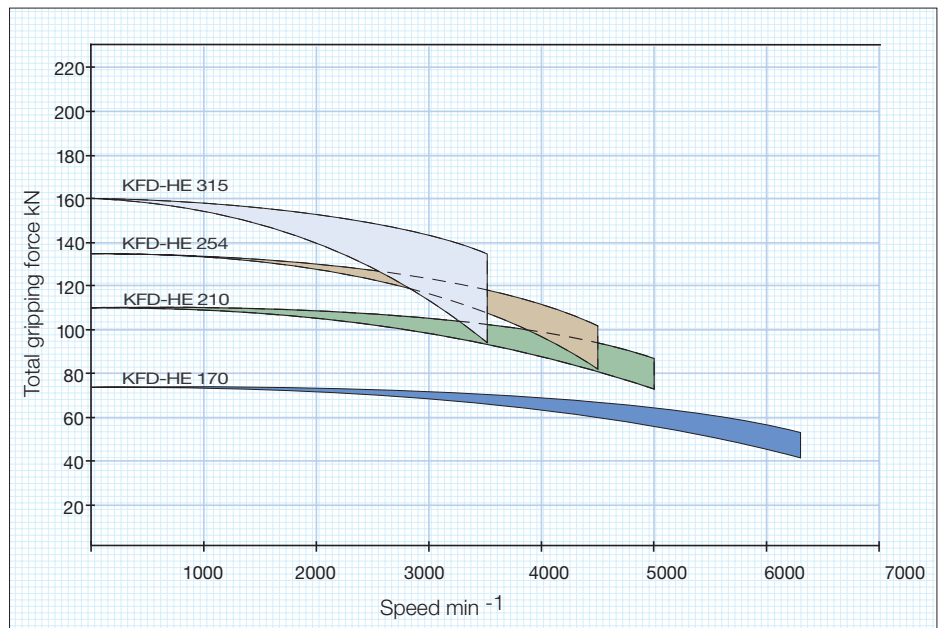

KFD-HE 3-jaw, standard design, serration 90°

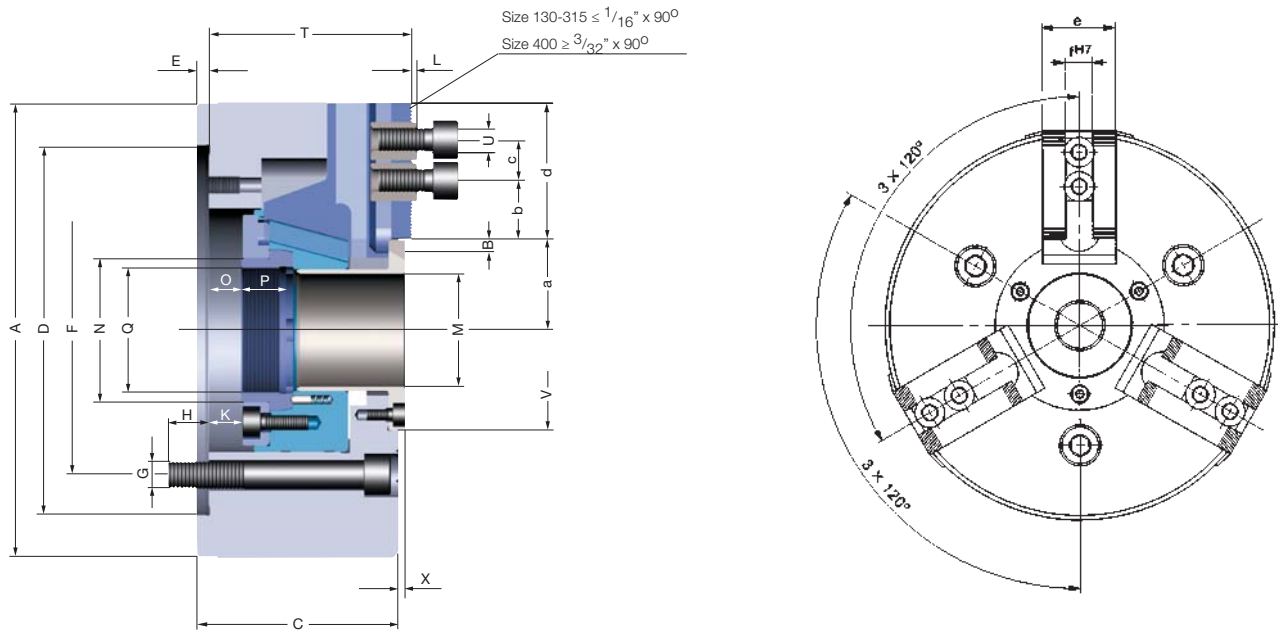

C 15
 3-jaw power chuck **KFD-HE**, serration 90°, cylindrical centre mount, mounting dimensions to **DIN 6353**

Item No.	154384	154031	154032	154829
Size	170	210	254	315
Number of jaws	3	3	3	3
A mm	170	210	254	315
Jaw travel B mm	3,2	4,3	5,1	5,3
C mm	82	93	101	114
D ⁶ mm	140	170	220	300
E mm	6	6	6	6
F mm	104,8	133,4	171,4	235
G mm	3 x M 10	3 x M 12	3 x M 16	3 x M 20
H mm	15	19	23	28
Wedge stroke K mm	14	16	19	23
L mm	2,5	2,5	2,5	2,5
Through-hole M mm	43	52	75	121
N mm	57	66	94	143
O min.	-2,6	-0,7	-10,3	-9,4
O max.	11,4	15,3	8,7	13,6
P mm	19	20,5	28	26
Q mm	M 52 x 1,5	M 58 x 1,5	M 82 x 1,5	M 126 x 1,5
T mm	82	93	101	114
U mm	M 8	M 12	M 16	M 16
V ^{H7} _{-0,05} mm	74	92	125	170
X mm	3	3	3	3
a min.	34,8	37,7	50,9	72,2
a max.	38	42	56	77,5
b min.	7,5	9	10	12
c min.	2 x 15	19	25	25
c max.	-	47	59	69
d mm	47	63	71	80
e mm	32	40	50	50
fH7-0,025 mm	12	17	21	21
Max. swing top jaws mm	230	290	345	410
Maximum draw bar pull kN	25	40	60	60
Max. total clamping force approx. kN	75	110	135	160
Max. admissible speed min ⁻¹	6300	5000	4500	3500
Moment of inertia J kgm ²	0,038	0,09	0,22	0,8
Weight without jaws approx. kg	12	18	29	50
Actuating cylinders (recommended)	OVS-105 / SZS-46/103	OVS-130 / SZS-52/130	OVS-150 / SZS-77/170	OVS-200 / SZS-127/325

Power chuck with through-hole KFD-HE

KFD-HE 3-jaw, universal draw tube connector, serration 60°

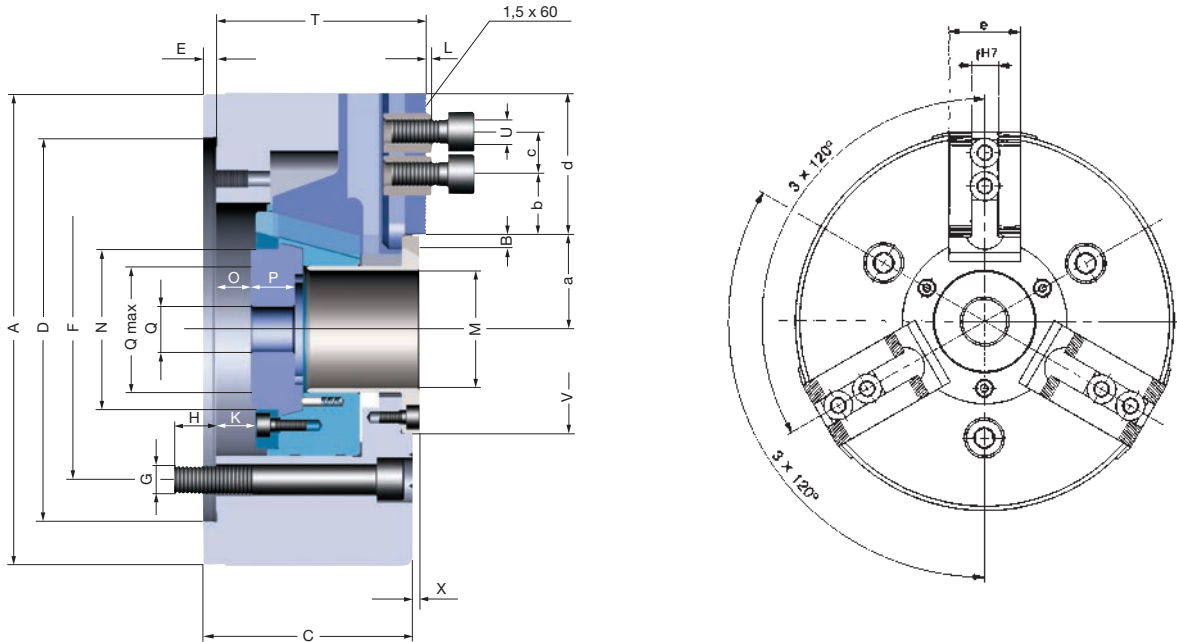

C 15
3-jaw power chuck KFD-HE, serration 60°, with pre-machined draw tube-connector, adaptor recess, cylindrical centre mount, mounting dimensions to DIN 6353

Item No.	154390	154391	154392▲	154830
Size	170	210	254	315
Number of jaws	3	3	3	3
A mm	170	210	254	315
Jaw travel B mm	3,4	4,3	5,1	5,3
C mm	82	93	101	114
D ¹⁶ mm	140	170	220	300
E mm	6	6	6	6
F mm	104,8	133,4	171,4	235
G mm	3 x M 10	3 x M 12	3 x M 16	3 x M 20
H mm	15	19	23	28
Wedge stroke K mm	14	16	19	23
L mm	3,2	3,2	3,2	3,2
Through-hole M mm	43	52	75	121
N mm	57	66	94	143
O min.	-2,6	-0,7	-10,3	-9,4
O max.	11,4	15,3	8,7	13,6
P mm	19	20,5	28	26
Q mm	Ø 20	Ø 30	Ø 45	Ø 60
Q max.	M 53 x 1,5	M 60 x 2	M 85 x 2	M 130 x 2
T mm	82	93	101	114
U mm	M 10	M 12	M 12	M 16
V ¹⁷ _{-0,05} mm	74	92	125	170
X mm	3	3	3	3
a min.	34,8	37,7	50,9	72,7
a max.	38	42	56	77,5
b min.	4,5	9	8	12
c min.	20	25	30	30
d mm	47	63	71	80
e mm	32	40	50	50
fH7-0,025 mm	12	14	16	21
Max. swing top jaws mm	230	290	345	410
Maximum draw bar pull kN	25	40	60	60
Max. total clamping force approx. kN	75	110	135	160
Max. admissible speed min ⁻¹	6300	5000	4500	3500
Moment of inertia J kgm ²	0,038	0,9	0,22	0,8
Weight without jaws approx. kg	12	18	29	50
Actuating cylinders (recommended)	OVS-105 / SZS-46/103	OVS-130 / SZS-52/130	OVS-150 / SZS-77/170	OVS-200 / SZS-127/325

Interchangeable with Kitagawa B-200A

Jaws KFD-HE

C 21

Reversible top jaws, 3-jaw set, hardened serration 90° - material: 16MnCr5



Chuck Size	3-jaw set	Jaw length mm	Jaw height mm	Jaw width mm	Serration
170	046404	56	37,5	26	1/16"x 90°
210	118522	75	49	36	1/16"x 90°
254/315	046414	103,5	58	50	1/16"x 90°

Additionally or later applied, hardened jaws must be ground out in the chuck.

C 21

Reversible top jaws, 3-jaw set, hardened serration 60° - material: 16MnCr5



Chuck Size	3-jaw set	Jaw length mm	Jaw height mm	Jaw width mm	Serration
170	154674¹⁾	66	36	34,7	1,5 x 60°
210	154676	81	49	36	1,5 x 60°
254	154678	99,5	54	44,5	1,5 x 60°
315	154816¹⁾	103	55,5	50	1,5 x 60°

¹⁾ One step only

Additionally or later applied, hardened jaws must be ground out in the chuck.

C 21

Soft top jaws, 3-jaw set, can be hardened serration 90° - material: 16MnCr5



Chuck Size	3-jaw set	Jaw length mm	Jaw height mm	Jaw width mm	Serration
170	046403	55	38	26,5	1/16"x 90°
210	133153	75	53	36,5	1/16"x 90°
254/315	133154	95	54,5	45	1/16"x 90°

C 21

Soft top jaws, 3-jaw set, can be hardened serration 60° - material: 16MnCr5



Chuck Size	3-jaw set	Jaw length mm	Jaw height mm	Jaw width mm	Serration
170	154865	72	43	30,5	1,5 x 60°
210	154867	95	45,5	35	1,5 x 60°
254	154869	110	45	50	1,5 x 60°
315	154871	130	55,5	50	1,5 x 60°

Jaws KFD-HE

C 21

Claw-type jaws, 1 piece, hardened serration 60° - width of the groove 12

Item no.	Chuck Size	Jaw length mm	Jaw height mm	Claw length mm	Serration
156025	170	67	45	53	1,5 x 60°
156027	170	65	45	46	1,5 x 60°
156029	170	55	45	40	1,5 x 60°
161189	170	55	45	24	1,5 x 60°

C 21

Claw-type jaws, 1 piece, hardened serration 60° - width of the groove 16

Item no.	Chuck Size	Jaw length mm	Jaw height mm	Claw length mm	Serration
156099	254	95	50	80	1,5 x 60°
156101	254	75	50	60	1,5 x 60°
156103	254	60	50	43	1,5 x 60°
156105	254	70	50	37	1,5 x 60°

C 21

Claw-type jaws, 1 piece, hardened serration 90° - width of the groove 17

Item no.	Chuck Size	Jaw length mm	Jaw height mm	Claw length mm	Serration
137031	210	67	45	53	1/16"x 90°
137032	210	65	45	46	1/16"x 90°
137039	210	55	45	40	1/16"x 90°
137034	210	50	45	31	1/16"x 90°
137035	210	55	45	27	1/16"x 90°
137036	210	65	45	19	1/16"x 90°
137037	210	65	45	26	1/16"x 90°
137038	210	55	45	24	1/16"x 90°
137033	210	55	45	39	1/16"x 90°

C 21

Claw-type jaws, 1 piece, hardened serration 90° - width of the groove 21

Item no.	Chuck Size	Jaw length mm	Jaw height mm	Claw length mm	Serration
137041	254/315	95	50	80	1/16"x 90°
137042	254/315	75	50	60	1/16"x 90°
137043	254/315	60	50	43	1/16"x 90°
137044	254/315	70	50	37	1/16"x 90°
137045	254/315	95	50	25	1/16"x 90°
137046	254/315	80	50	30	1/16"x 90°

Accessories KFD-HE

C 15 T-nuts
with screw, for SV 1/16" x 90°

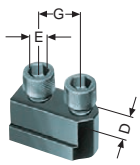

Item no.	Chuck Size	Con- tents of delivery	D mm	E	G mm
1305166	170	piece	12	M8x20	2x15
1305172 ¹⁾	210	Piece	17	M12x25	-
1356253	254/315	piece	21	M16x30	-

¹⁾ Simple slot nut

C 15 T-nuts
with screw, for SV 1,5" x 60°

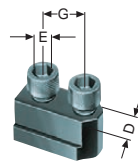

Item no.	Chuck Size	Con- tents of delivery	D mm	E	G mm
1028192 ▲	170	piece	12	M10x25	20
1028193	210	piece	14	M12x30	25
1028194	254	piece	16	M12x30	30
1028196	315	piece	21	M16x40	30

C 15 Special grease F80 for lathe chucks
for lubrication and conservation of clamping force



Item no.	Design	Contents
308555	Cartridge	0,5 kg
028975	Tin	1 kg

C15 Grease gun DIN1283



Item no.	Conne- tion	Contents of delivery
329093	M10x1	150 mm nozzle tube bent, needlepoint mouthpiece, top mouthpiece, 300 mm high pressure hose with 4 jaw hydraulics cross mouthpiece

Accessories KFD-HE

C 15
Intermediate adaptor plates with cylindrical centre mount DIN 6353 for 3-jaw chucks
Mounting from front to ISO 702-1 (DIN 55026/55021) and ASA B 5.9 A1/A2 with metric mounting bolts

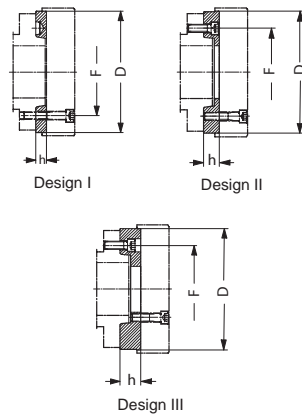

Item no.	Spindle nose size	Size	Design	h mm	F mm	D mm
145125 ¹⁾	4	170	II	18	82,6	140
145153	5	170	I	15	104,8	140
145127	5	210	II	21	104,8	170
145129	6	170	III	35	133,4	140
145155	6	210	I	16	133,4	170
145131	6	254	II	27	133,4	220
145135	8	210	III	39	171,4	170
145157	8	254	I	18	171,4	220
145139 ▲	8	315	II	38	171,4	300
145143 ▲	11	254	III	48	235	220
145159	11	315	I	19	235	300

All fastening parts are included
¹⁾ DIN 55021 auf Anfrage

Jaw dimensions KFD-HE

Reversible top jaws UB,
hardened, serration 90°,
material 16MnCr5

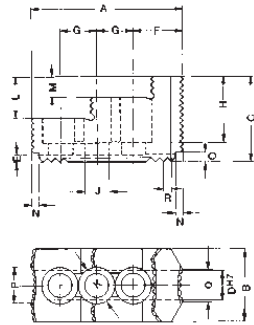

Chuck size	170	210	254/315
Type	537-02	538-04	538-05
Item no. 3-jaw	046404	118522	046414
A	56	75	103,5
B	26	36	50
C	37,5	49	58
DH7	12	17	21
E	3,5	5	5
F	14	21,5	33,5
G	15	19	25
H	29	37,5	45
J	8,4	13	17
K	13,5	19	25
L	20	24	28
M	10	12	14
N	4	6	6
O	4	7,5	6,5
P	5	18	24,5
Q	5	7	22,5
R	1/16"x90°	1/16"x90°	1/16"x90°
Weight/jaw kg	0,130	0,460	1,130

Soft top jaws AB,
serration 90°,
material 16MnCr5

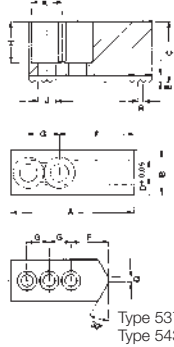

Chuck size	170	210	254/315
Type	538-02	538-04	538-05
Item no. 3-jaw	046403	133153	133154
A	55	75	95
B	26,5	36,5	45
C	38	53	54,5
D	12	17	21
E	3,5	5	5
F	31	44	55
G	15	19	25
H	28	43	42,5
J	8,4	13	17
K	13,5	19	25
Q	-	-	-
R	1/16"x90°	1/16"x90°	1/16"x90°
Weight/jaw kg	0,320	0,880	1,400

Reversible top jaws UB,
serration 60°,
material 16MnCr5

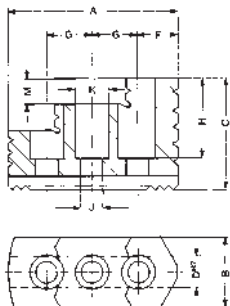

Chuck size	170	210	254	315
Type	543-31	543-31	543-31	543-31
Item no. 3-jaw	154674 1)	154676	154678	154816 1)
A	66	81	99,5	103
B	34,7	36	44,5	50
C	36	49	54	55,5
D	12	14	16	21
F	12,5	17,5	25,5	22,5
G	20	25	30	30
H	23	36,5	38,5	34
J	11	13	13	17
K	17	19	19	25
Serration	1,5 x 60°	1,5 x 60°	1,5 x 60°	1,5 x 60°
Weight/jaw kg	0,3	0,6	1,2	1,5

1) One step only

Soft top jaws AB,
can be hardened, serration 60°,
material 16MnCr5

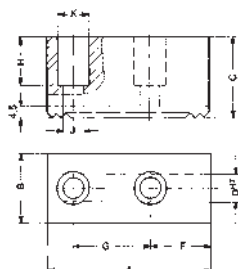

Chuck size	170	210	254	315
Type	543-32	543-32	543-32	543-32
Item no. 3-jaw	154865	154867	154869	154871
A	72	95	110	130
B	32,5	35	50	50
C	40	45,5	45	55,5
D	12	14	16	21
F	37	46	50	52
G	20	25	30	30
H	27	33	29	34
J	11	13	13	17
K	17	19	19	25
Serration	1,5 x 60°	1,5 x 60°	1,5 x 60°	1,5 x 60°
Weight/jaw kg	0,5	0,9	1,7	1,9

Chucking capacities KFD-HE

Claw-type jaws KB
serration 90°

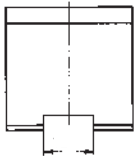
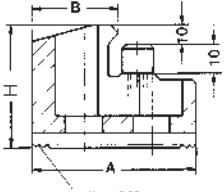

Piece	A	B	KFD-HE 170 1,5 x 60° External chucking
Item no.			
156025	67	53	39-83
156027	65	46	52-98
156029	55	40	78-124
161189	55	24	110-155
Piece	A	B	KFD-HE 170 1,5 x 60° Internal chucking
Item no.			
161189	55	24	92-135
156029	55	40	125-168
159027	65	46	150-190

Piece	A	B	KFD-HE 210 1/16x90° External chucking
Item no.			
137031	67	53	60-96
137032	65	46	73-111
137039	55	40	88-127
137034	50	31	105-142
137035	55	27	119-157
Piece	A	B	KFD-HE 210 1/16x90° Internal chucking
Item no.			
137036	65	19	72-110
137037	65	26	90-125
137038	55	24	104-144
137035	55	27	124-156
137034	50	31	136-163
137039	55	40	144-175
137033	55	39	154-205
137032	65	46	168-218

Piece	A	B	KFD-HE 254 1,5 x 60° External chucking
Item no.			
156099	95	80	60-102
156101	75	60	99-140
156103	60	43	132-174
156105	70	37	163-205
Piece	A	B	KFD-HE 254 1,5 x 60° Internal chucking
Item no.			
156101	75	60	222-275
156103	60	43	188-250
156105	70	37	158-198

Piece	A	B	KFD-HE 254 1/16x90° External chucking	KFD-HE 315 1/16x90° External chucking
Item no.				
137041	95	80	53-95	66-160
137042	75	60	92-133	105-198
137043	60	43	125-167	138-232
137044	70	37	156-198	169-263
Piece	A	B	KFD-HE 254 1/16x90° Internal chucking	KFD-HE 315 1/16x90° Internal chucking
Item no.				
137045	95	25	68-112	81-177
137046	80	30	108-154	121-219
137044	70	37	146-186	159-240
137043	60	43	178-240	191-305
137042	75	60	212-265	225-330

Chucking capacities KFD-HE

Chucking capacities with reversible top jaws UB

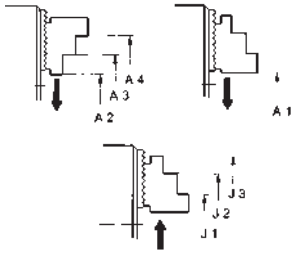

Chuck size		170	210	254	315
with reversible jaws 1/16" x 90°	Type	538-02	538-04	538-05	538-05
	Jaw position				
External chucking	A1	20-83	19-108	25-134	57-189
	A2	-	36-128	48-162	50-217
	A3	80-150	94-182	130-226	134-297
	A4	120-192	145-234	210-272	212-332
Internal chucking	J1	63-130	78-156	80-190	70-233
	J2	102-173	128-209	156-261	146-313
	J3	154-210	181-263	246-338	236-393

Chuck size		170	210	254	315
with reversible jaws 1,5 x 60°	Type	543-31	543-31	543-31	543-31
	Jaw position				
External chucking	A1	17-100	19-111	25-130	28-190
	A2	-	-	-	-
	A3	97-174	82-170	124-219	-
	A4	-	133-224	170-265	170-317
Internal chucking	J1	74-154	63-160	84-197	116-271
	J2	-	112-213	129-244	-
	J3	-	170-273	211-328	-



Notes

KFG - power operated angle lever chuck



APPLICATION

Optimally suited for clamping tasks demanding through-hole, flexibility, large strokes and low frictional losses.

TYPE

Angle lever power chuck with cylindrical centre mount.
3-jaw version with serration 60°.

CUSTOMER BENEFITS

- ③ Large through-hole
- ③ Large jaw strokes and flexible use can be realized with angle lever system
- ③ High efficiency thanks to low frictional losses (low-hysteresis chuck)
- ③ Long service life - all moving parts are hardened and ground

TECHNICAL FEATURES

- Wide guidance of base jaws
- T-slots in the chuck body
- Lubrication of the jaw guide via easily accessible grease nipples on the axes of the angle lever

Included in the scope of delivery:

Chuck, chuck and jaw mounting screws, wrench, slot nuts, 2 wrenches for the sliding sleeve (without top jaws)



Big range of applications thanks to large through-hole. Suitable for bar machining and other different workpieces. The axial pull force is translated into the radial jaw movement supported by the angle lever.

KFG - Extra large jaw stroke

KFG 3-jaw, large jaw movement, serration 60°

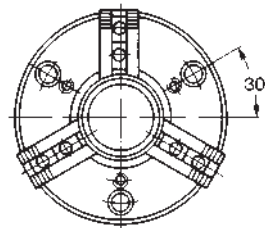
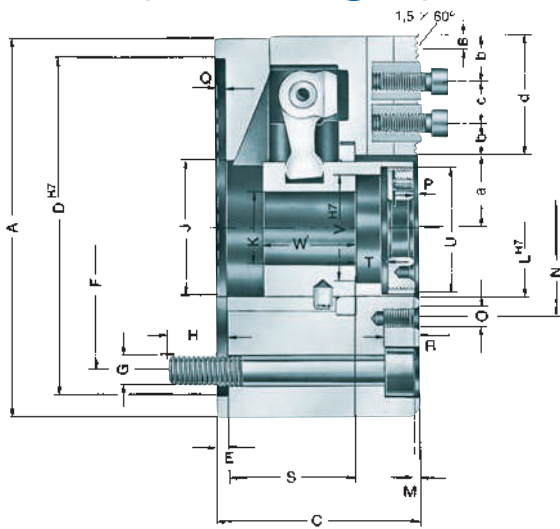

KFG 160

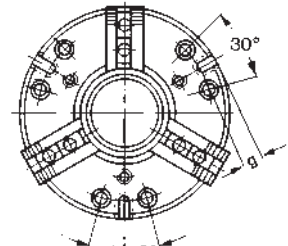

KFG 215 - 350

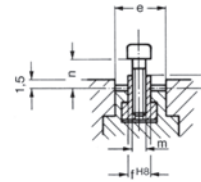

Serration base jaw

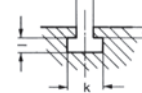

Clamping groove from KFG 215

C 15
3-jaw angle lever power chucks KFG, large jaw movement, with serration 60°, cylindrical centre mount

Item No.	020666 ▲	020667 ▲	020668 ▲	020669 ▲
Size	160	215	280	350
Number of jaws	3	3	3	3
A mm	160	215	280	350
Jaw travel B mm	16	20	25	25
C mm	79	92	116,2	134,7
DH7	140	190	255	320
E mm	4,2	4,2	5,7	5,7
F mm	104,8	133,4	133,4	171,4
G	3xM10	6xM12	6xM12	6xM16
H mm	20	25	25	35
J mm	54	74	102	135
K mm	26	45,5	66,5	90,5
LH7 mm	66	80	105	140
M mm	2,5	2,5	2,5	2,5
N mm	76	90	120	156
O	M6	M 8	M 8	M 10
P mm	14	16,5	18,7	13,1
Q mm	3,2	3,7	3,2	4,1
R mm	13	15	15	20
S min.	19,8	25,3	28,8	32,9
S max.	39,8	50,3	63,8	77,9
T mm	8	12	18	22
U mm	M46x1,25	M65x1,25	M90x1,25	M112x1,5
V ^{H7} mm	43	62	87	109
W mm	23	29	32	37
a min.	23	31,5	47,5	69,5
a max.	39	51,5	72,5	94,5
b mm	8	10	13	14
c min.	16	20	26	28
c max.	41	46	54	65
d mm	57	66	80	93
e mm	28	35	45	50
fH8 mm	11	14	20	21
g mm	-	35	63	73,5
h mm	-	16	16	22
i mm	-	10	10	15
k mm	-	24	24	35
l mm	-	10	10	17
m mm	M8	M10	M12	M16
n mm	7,5	8,5	13	15
o mm	1,5	1,5	2,5	3
Max. swing top jaws mm	242	295	380	480
Maximum draw bar pull kN	24	33,9	43	52
Max. total clamping force approx. kN	21	30	42	66
Max. admissible speed min ⁻¹	3400	2700	1950	1800
Moment of inertia J kgm ²	0,031	0,11	0,425	1,22
Weight without jaws approx. kg	9,3	17	41	75
Actuating cylinders (recommended)	OVS-105 / SZS-37/70	OVS-130 / SZS-46/103	OVS-150 / SZS-67/150	OVS-150 / SZS-86/200

Power chucks with through-hole KFG

Jaws KFG

C 21

Reversible top jaws, 3-jaw set, hardened serration 60° - material: 16MnCr5

Item no.	Chuck Size	Jaw length mm	Jaw height mm	Jaw width mm	Serration
046410	160	62	37,5	26	1,5 x 60°
046412 ¹⁾	215	81	52,5	36	1,5 x 60°
046416	280	96	54	44,5	1,5 x 60°
046422	350	112	61	49,5	1,5 x 60°

¹⁾ Lowered to 34 mm in the serration area

Reversible top jaws UB: Ground out on the associated chuck at extra charge

C 21

Soft top jaws, 3-jaw set, can be hardened serration 60° - material: 16MnCr5

Item no.	Chuck Size	Jaw length mm	Jaw height mm	Jaw width mm	Serration
046409	160	66,7	43	30,5	1,5 x 60°
046411	215	88,9	53	36,5	1,5 x 60°
046415	280	88,9	54,5	45	1,5 x 60°
046421	350	120	80	50	1,5 x 60°

Accessories KFG

C 15 T-nuts

with screw, for SV 1,5° x 60°

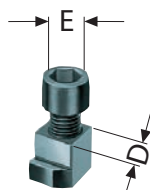

Item no.	Chuck Size	Contents of delivery	D mm	E
1305174 ▲	160	piece	11	M8x18
1305175 ▲	215	piece	14	M10x20
1305176 ▲	280	piece	20	M12x30
1305177 ▲	350	piece	21	M16x35

Jaw dimensions und chucking capacities KFG

Reversible top jaws UB,
hardened, serration 60°,
material 16MnCr5

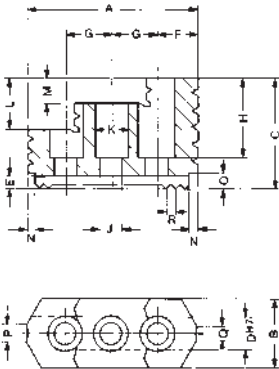

Chuck size	160	215	280	350
Type	530-05	530-07	530-09	530-12
Item no. 3-jaw	046410	046412	046416	046422
A	62	81	96	112
B	26	36 1)	44,5	49,5
C	37,5	52,5	54	61
D	11	14	20	21
E	3,5	5	5	5,5
F	17,5	25	30	27
G	16,5	21	26	33
H	29	41	41	47,5
J	8,4	10,5	13	17
K	13,5	16,5	19	25
L	20	24	24	30
M	10	12	12	15
N	4	5	5	6,5
O	4	7	7	7
P	5	10	10	13
Q	5	5	5	13
R	1,5 x 60°	1,5 x 60°	1,5 x 60°	1,5 x 60°
Weight/jaw kg	0,215	0,600	0,750	1,550

1) Near the serration reduced to 34 mm
Reversible top jaws: ground to finished size at surcharge

Soft top jaws AB,
material 16MnCr5

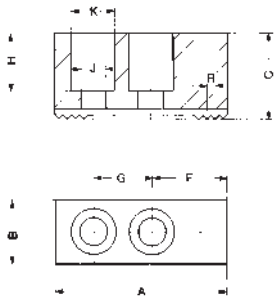

Chuck size	160	215	280	350
Type	530-05	530-07	530-09	530-12
Item no. 3-jaw	046409	046411	046415	046421
A	66,7	88,9	88,9	120
B	30,5	36,5	45	50
C	43	53	54,5	80
D	11	14	20	21
E	3,5	5	5	5
F	30	45	45	67
G	20	26	26	28
H	33	41	42,5	67
J	8,4	10,5	13	17
K	13,5	16,5	19	25
L	-	-	-	-
M	27	34	-	-
R	1,5 x 60°	1,5 x 60°	1,5 x 60°	1,5 x 60°
Weight/jaw kg	0,550	1,125	1,400	3,125

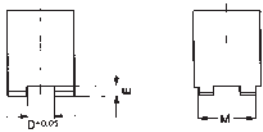

AB 530-04 und 530-07

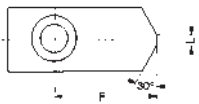

AB 530-02

Chucking capacities with
reversible top jaw UB

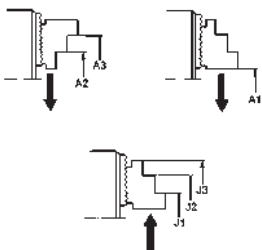

Chuck size		160	215	280	350
with reversible jaws	Type	530-04	530-07	530-09	530-12
	Jaw position				
External chucking	A1	5-115	5-136	11-185	50-248
	A2	58-175	81-220	123-295	159-354
	A3	92-208	132-272	190-363	242-438
Internal chucking	J1	52-159	61-186	70-238	108-301
	J2	85-193	109-238	133-305	189-385
	J3	129-240	167-298	202-378	274-472

PKF - air-operated wedge hook chuck



APPLICATION

Suitable for very high concentricity and clamping repeatability.

TYPE

Air-operated high precision wedge hook clamping chuck.

CUSTOMER BENEFITS

- ⊕ Concentricity and axial run-out precision within 0.003 mm
- ⊕ High amount of safety in event of pressure failure thanks to self-locking
- ⊕ Low-maintenance thanks to oil-mist lubrication
- ⊕ Optimal adaption of the clamping force for clamping deformation-sensitive parts thanks to large actuation range from 2-10 bar

TECHNICAL FEATURES

- Clamping piston construction with power transmission on both sides according to the ROHM KFD-HS principle
- Integrated pneumatic operation
- Through-hole for coolant supply for sizes 100-200

Note:

Please order air supply tube, maintenance unit, top jaws and actuation valves separately

Included in the scope of delivery:

Chuck, chuck and jaw mounting screws (without top jaws)

PKF = precision, wedge hook, clamping chuck

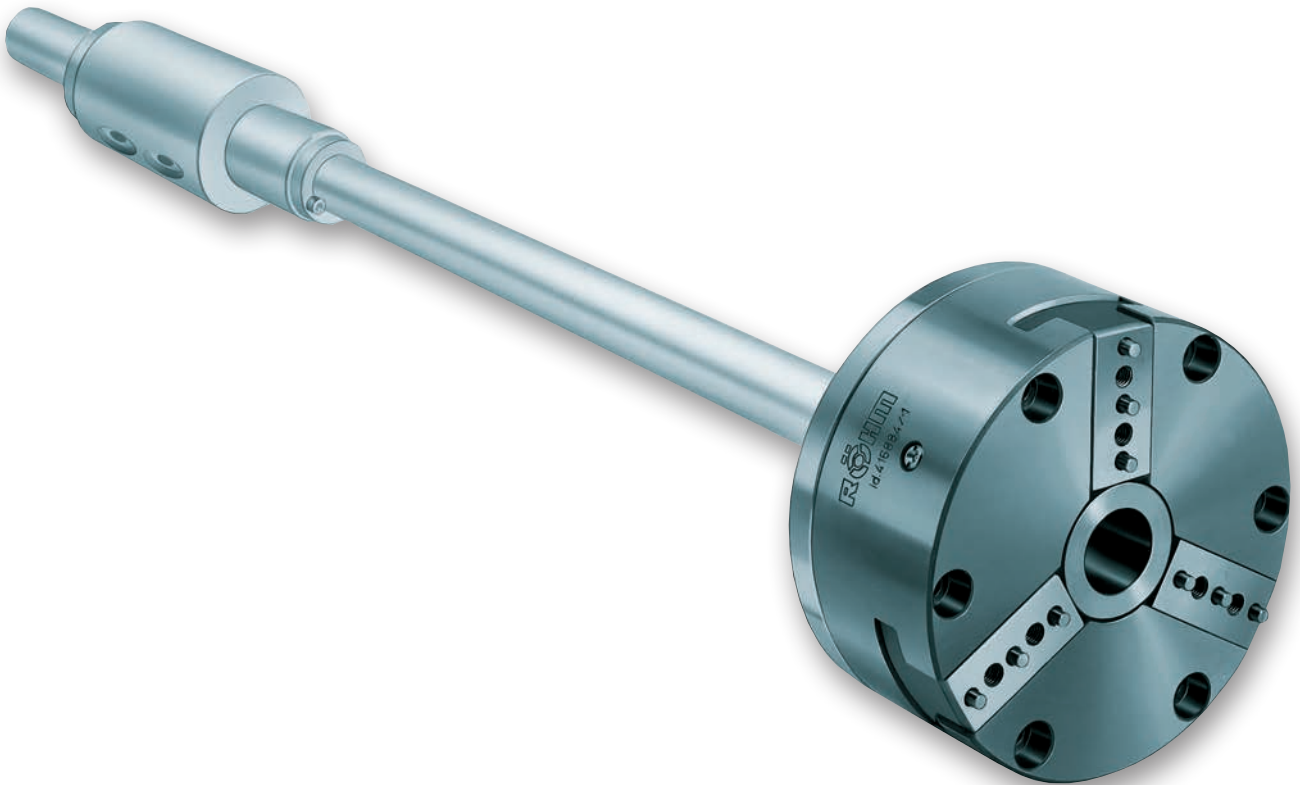

PKF air-operated wedge hook chuck

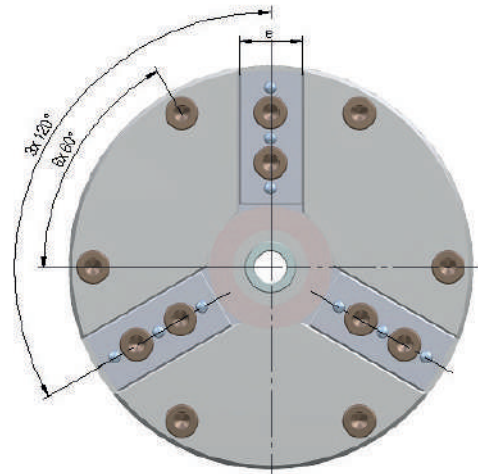
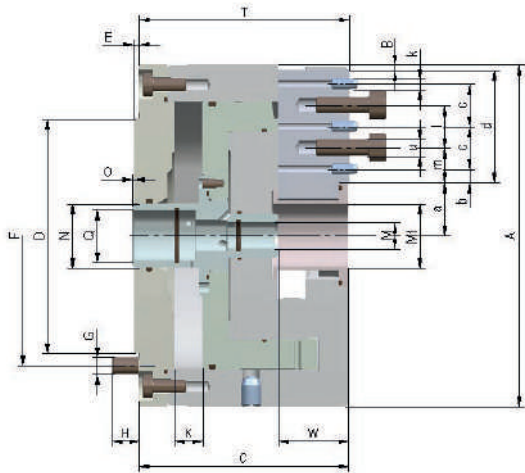

C 15
High-precision air-operated lathe chuck **PKF**, concentricity 0.003 mm, repetitive clamping accuracy 0.0015 mm with through-hole, pneumatically operated, with integrated **pneumatic piston**, clamping precision in the μ range

Item No.	153706 ▲	153707 ▲	153708 ▲	153709 ▲	153710 ▲
Size	100	100	150	150	200
A mm	102	102	151	151	202
Jaw travel B mm	0,75	1,5	0,75	1,5	1,5
C mm	52,5	62,5	52,5	62,5	85,5
D-0,01	82,55	82,55	124,97	124,97	167,64
E mm	1,5	1,5	1,5	1,5	3,2
F mm	88,9	88,9	135,9	135,9	182,9
G	M5	M5	M6	M6	M10
H mm	8	8	9	9	16
Wedge stroke K mm	4,25	8,5	4,25	8,5	8,5
M mm	3,2	3,2	3,2	3,2	3,2
M1 mm	19	19	25,4	25,4	25,4
N mm	19	19	19	19	19
O min.	0,5	0,5	0,5	0,5	0,5
O max.	4,75	9	4,75	9	9
Q mm	5/8"	5/8"	5/8"	5/8"	5/8"
W mm	19	19	19	19	35
T mm	52,8	62,8	52,8	62,3	85,9
a min.	16,75	16	22,75	22	21,9
a max.	17,5	17,5	23,5	23,5	23,4
b mm	3,9	3,9	14,9	14,9	4,5
c mm	2 x 12,7	2 x 12,7	2 x 12,7	2 x 12,7	2 x 31,75
d mm	33,5	33,5	52	52	76,1
e mm	16	16	24	24	32
k mm	1/8"	1/8"	1/8"	1/8"	1/4"
l mm	12,7	12,7	3 x 12,7	3 x 12,7	31,75
m mm	10,25	10,25	8,55	8,55	20,375
u	2 x M5	2 x M5	4 x M5	4 x M5	M10
Operating pressure bar	2-10	2-10	2-10	2-10	2-10
Area A1 clamping cm ²	47,4	47,4	100	100	185,0
Area A2 releasing cm ²	28,9	28,9	69	69	111,5
Total clamping force at 8 bar kN	13	13	27	27	31,5
Max. admissible speed at 8 bar min ⁻¹	5500	5500	4000	4000	3000
Moment of inertia J kgm ²	0,0029	0,0029	0,015	0,015	0,08
Weight kg	3,0	3,5	6,8	7,9	19,8

Higher speeds available on request

Jaws PKF

C 21
Soft top jaws steel version, set of 3-jaws



Item no.	Chuck Size	Jaw length mm	Jaw height mm	Jaw width mm
153818 ▲	100	49	25	18,4
153819 ▲	150	74	30	26,5
153820 ▲	200	95	46	34,7

Accessories PKF

C 15
Air-operated control LSG R^{1/4} up to 10 bar, for air-operated power chucks



Item no.	Width mm	Height mm	Depth mm	Control voltage	Conn. thread
437107 ▲	380	380	210	24V DC	R 3/8" internal

Other control voltage on request

C 15
Service unit for air operated control
This unit consists of: separator and filtre CKS-08/10 and lubricator CL-08/10



Item no.	Width mm	Height mm	Depth mm
216084 ▲	130	240	102

Max. flow Qn 33m³/h at 6 bar

C 15
Manually operated air control valve LHV with 2 switch settings and a safety switch lever



Item no.	Width mm	Height mm	Depth mm	Conn. thread internal	Conn. thread external
418224 ▲	66,5	64	38	R 1/4"	M 16 x 1,5

A09 Special grease F80 for lathe chucks
For lubrication and conservation of chucking power



Item no.	Design	Contents
308555	Cartridge (DIN 1284) Ø 53.5x235mm	0,5 kg
028975	Tin	1 kg

C15 Grease gun DIN1283



Item no.	Connection	Contents of delivery
329093	M10x1	150 mm nozzle tube bent, needlepoint mouthpiece, top mouthpiece, 300 mm high pressure hose with 4 jaw hydraulics cross mouthpiece

Accessories PKF

Air supply tube

Air supply tube 3/8" and 5/8"
 Type 586-80
 Max. speeds = 10 000 min⁻¹
 Central through-hole for air and coolant.
 Max. air pressure = 10 bar

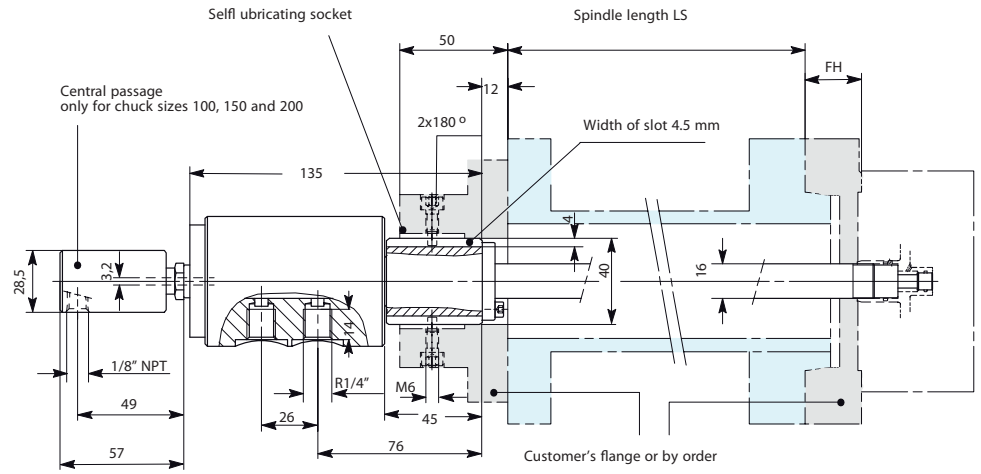

Ordering indications for air supply tube:

Chuck size + spindle length LS + height of flange FH

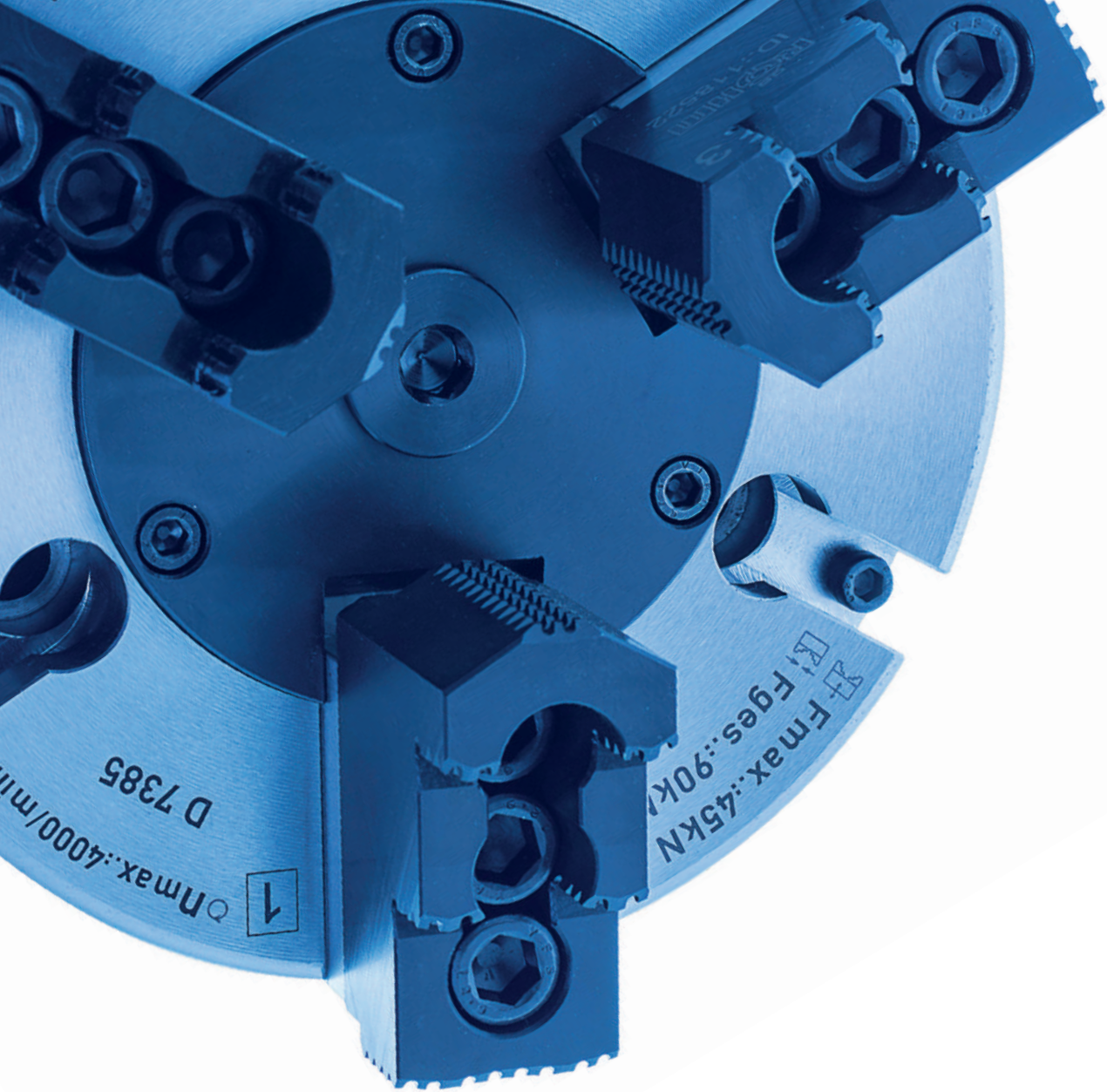

PROVEN WEDGE HOOK SYSTEM

Founded in 1909, RÖHM began successively expanding their product range by the area of power chuck technology starting in 1950. Decades of experience and knowledge about power chucks make today's RÖHM power chucks so successful. These are not only characterized by their long service life, but also by the top precision and reliability.

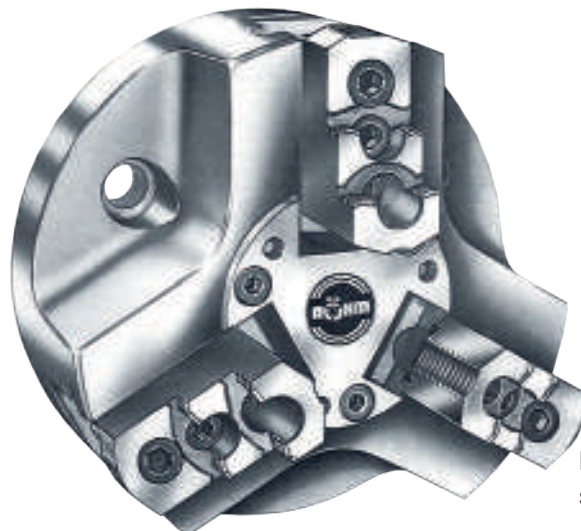

Power chuck KFD with wedge hook system without through-hole

POWER CHUCKS WITHOUT THROUGH-HOLE

The RÖHM power chucks without through-hole have already been used for decades and have proven themselves many times over in various clamping tasks. Thanks to the wedge hook system as well as the rigid chuck construction, the power chucks achieve a high load capacity and clamping precision along with a long service life.

ADVANTAGES AT A GLANCE

- ⊕ Proven power chucks with long service life
- ⊕ Wedge hook system for high load capacity and clamping precision
- ⊕ Simple setup as basis for a wide range of applications

High load capacity thanks to proven wedge hook system

Different tothing types for different jaw variants

Protection against dirt and chips with cover

Rigid chuck construction for high clamping precisions

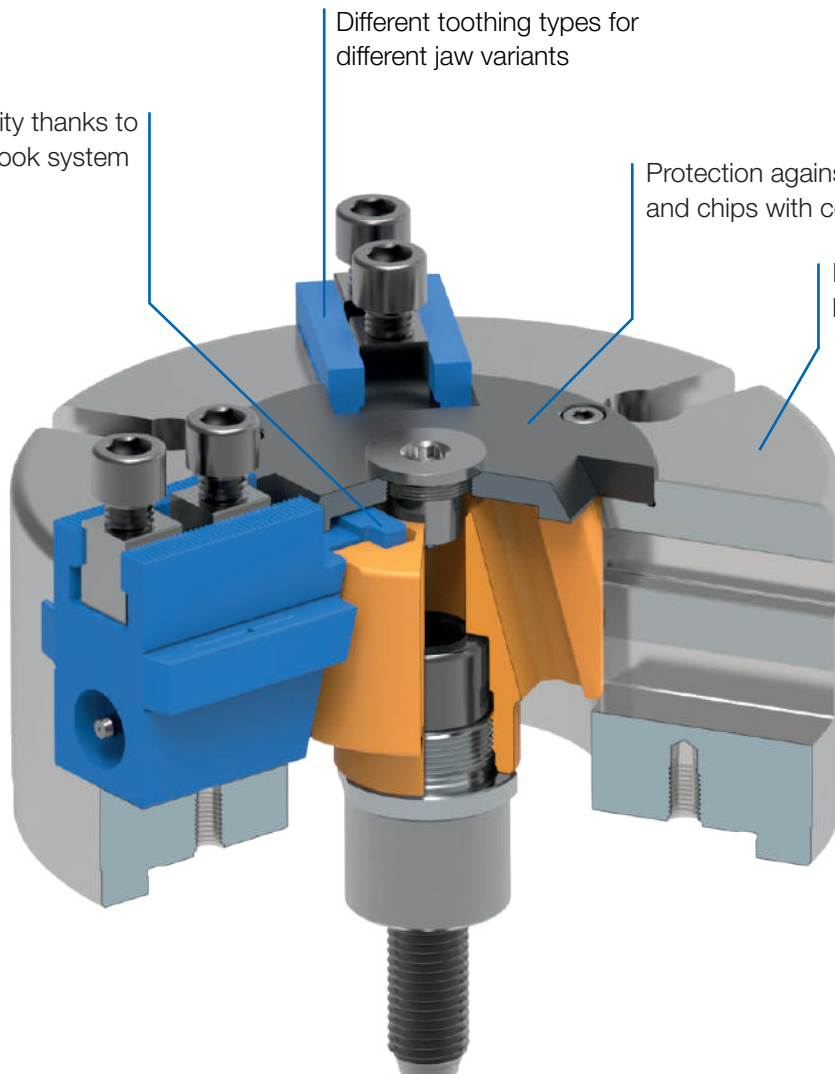

KFD-EC - low-maintenance and -wear



APPLICATION

Especially for use under extreme operating conditions, e.g. dry or raw part machining and / or high coolant pressure.

TYPE

Power chuck with cylindrical centre mount.
3-jaw version with serration 90°.

CUSTOMER BENEFITS

- ③ Easy Care: Low-maintenance and -wear
- ③ Lubrication interval, depending on operating conditions, up to approx. 600 operating hours
- ③ Optimized protection against the penetration of dirt thanks to seals built into the jaw guides

TECHNICAL FEATURES

- Proven wedge hook system

Note:

KFD-F-EC with centrifugal force compensation on request

Included in the scope of delivery:

Chuck, chuck and jaw mounting screws, slot nuts (without top jaws)



Structure KFD-EC

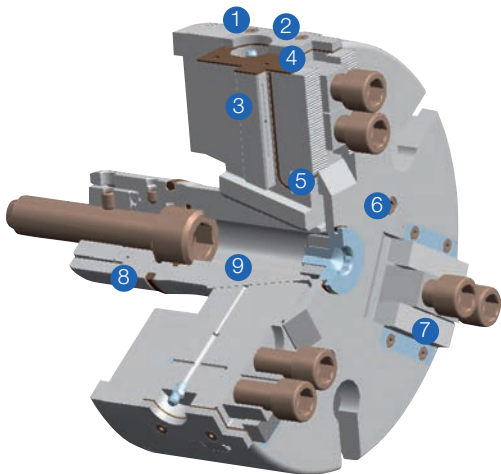

- ① Body
- ② End cover
- ③ Base jaw
- ④ Flat seal
- ⑤ Square ring
- ⑥ Cover
- ⑦ Wiper plates
- ⑧ O-Ring
- ⑨ Piston

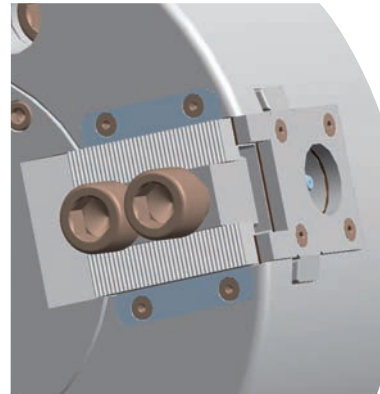

KFD-EC 3-jaw, serration 90°

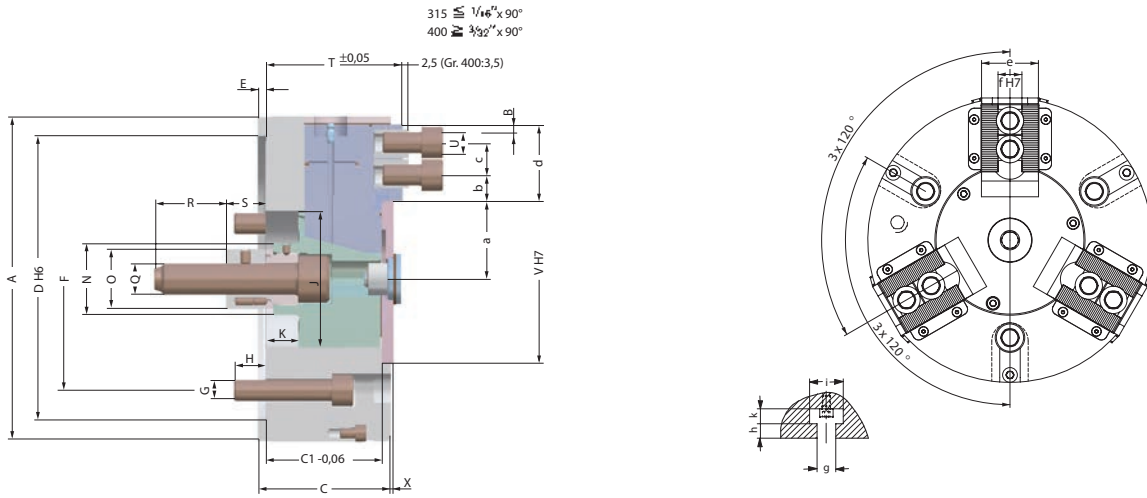

Low maintenance 3-jaw power chuck KFD-EC, with short piston, without force compensation, centric clamping cylindrical centre mount, mounting dimensions to DIN 6353

Item No.	166183	166184▲	166185▲	166186▲
Size	200	250	315	400
A mm	200	250	315	400
Jaw travel B mm	6,7	6,7	8	9,3
C mm	86	98	113	121
C1 _{-0,06} mm	80	92	107	115
Mount D ^{H6}	170	220	300	300
E mm	6	6	6	6
F mm	133,4	171,4	235	235
G mm	3xM12	3xM16	3xM20	3xM20
H mm	18	23	31	30
J mm	85	105	120	155
Wedge stroke K mm	25	25	30	35
N mm	45	55	60	60
O mm	40	46	46	55
Q mm	M20	M24	M24	M24
R mm	45	55	55	55
S min.	30	30	30	30
S max.	55	55	60	65
T ^{±0,05} mm	90	105	120	130
U	M12x25	M16x30	M16x30	M20x40
V ^{H7} mm	110	130	160	190
X mm	7	7	9	9
a min.	43,3	53,3	59,5	77,7
a max.	50	60	67,5	87
b min.	8	10	10	14
c min.	19	25	25	31
c max.	34,5	47,5	70,5	87
d mm	45	59	84	107
e mm	35	50	55	60
f ^{H7} mm	17	21	21	25,5
g mm	14	18	18	22
h mm	11	13	13	22
i mm	11	14	14	18
k mm	25	32	32	40
Maximum draw bar pull kN	45	65	80	95
Max. total clamping force kN	90	140	190	250
Max. admissible speed min ⁻¹	4000	3200	2800	2000
Moment of inertia J kgm ²	0,1	0,28	0,89	2,02
Weight without jaws approx. kg	19,3	34,8	63,6	88,4
Actuating cylinders (recommended)	OVS-130	OVS-150	OVS-150	OVS-200

Intermediate adaptors for short taper mount on request

Power chuck without through-hole KFD-EC

Jaws KFD-EC

C 21

Reversible top jaws, 3-jaw set, hardened, serration 90° - material: 16MnCr5

Item no.	Chuck Size	Jaw length mm	Jaw height mm	Jaw width mm	Serration
118522	200	75	49	36	1/16"x 90°
046414	250/315	103,5	58	50	1/16"x 90°
037531	400	135	65	68	3/32"x 90°

Additionally or later applied, hardened jaws must be ground out in the chuck.

C 21

Soft top jaws, 3-jaw set, can be hardened, serration 90° - material: 16MnCr5

Item no.	Chuck Size	Jaw length mm	Jaw height mm	Jaw width mm	Serration
133153	200	75	53	36,5	1/16"x 90°
133154	250	95	54,5	45	1/16"x 90°
133155	315	103	80	50	1/16"x 90°
133156	400	130	80	50	3/32"x 90°

C 21

Claw-type jaws, 1 piece, hardened, serration 90° - width of the groove 17

Item no.	Chuck Size	Jaw length mm	Jaw height mm	Claw length mm	Serration
137031	200	67	45	53	1/16"x 90°
137032	200	65	45	46	1/16"x 90°
137033	200	55	45	39	1/16"x 90°
137034	200	50	45	31	1/16"x 90°
137035	200	55	45	27	1/16"x 90°
137036	200	65	45	19	1/16"x 90°
137037	200	65	45	26	1/16"x 90°
137038	200	55	45	24	1/16"x 90°
137039	200	55	45	40	1/16"x 90°

C 21

Claw-type jaws, 1 piece, hardened, serration 90° - width of the groove 21

Item no.	Chuck Size	Jaw length mm	Jaw height mm	Claw length mm	Serration
137041	250/315	95	50	80	1/16"x 90°
137042	250/315	75	50	60	1/16"x 90°
137043	250/315	60	50	43	1/16"x 90°
137044	250/315	70	50	37	1/16"x 90°
137045	250/315	95	50	25	1/16"x 90°
137046	250/315	80	50	30	1/16"x 90°

C 21

Claw-type jaws, 1 piece, hardened, serration 90° - width of the groove 25,5

Item no.	Chuck Size	Jaw length mm	Jaw height mm	Claw length mm	Serration
137051	400	130	65	113	3/32"x 90°
137052	400	90	65	67	3/32"x 90°
137053	400	100	65	45	3/32"x 90°
137054	400	130	65	33	3/32"x 90°

Accessories KFD-EC

C 15 T-nuts
With screw

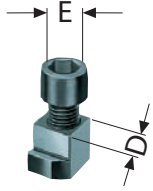

Item no.	Contents of delivery	D mm	E
241674	piece	17	M12x25
241675	piece	21	M16x30
241676 ¹⁾	piece	25,5	M20x40

¹⁾ Metric dimensions

C 15 Special grease F80 for lathe chucks
for lubrication and conservation of clamping force



Item no.	Design	Contents
028975	Tin	1 kg
308555	Cartridge	0,5 kg

Accessories KFD-EC

C 15 Intermediate adaptor plates with cylindrical centre mount DIN 6353 for 3-jaw chucks
Mounting from front to ISO 702-1 (DIN 55026/55021) and ASA B 5.9 A1/A2 with metric mounting bolts

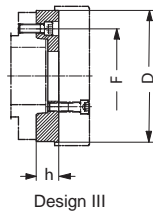
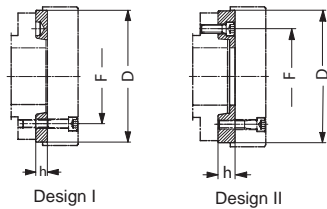

Item no.	Spindle nose size	Size	Design	h mm	F mm	D mm
145127	5	200	II	21	104,8	170
145155	6	200	I	16	133,4	170
145131	6	250	II	27	133,4	220
145135	8	200	III	39	171,4	170
145157	8	250	I	18	171,4	220
145137 ▲	8	315/400	II	38	171,4	300
145143 ▲	11	250	III	48	235	220
145159	11	315	I	19	235	300
145149	15	400	III	58	330,2	300

All fastening parts are included
Intermediate adaptor plate for 2- and 4-jaw version on request

KFD

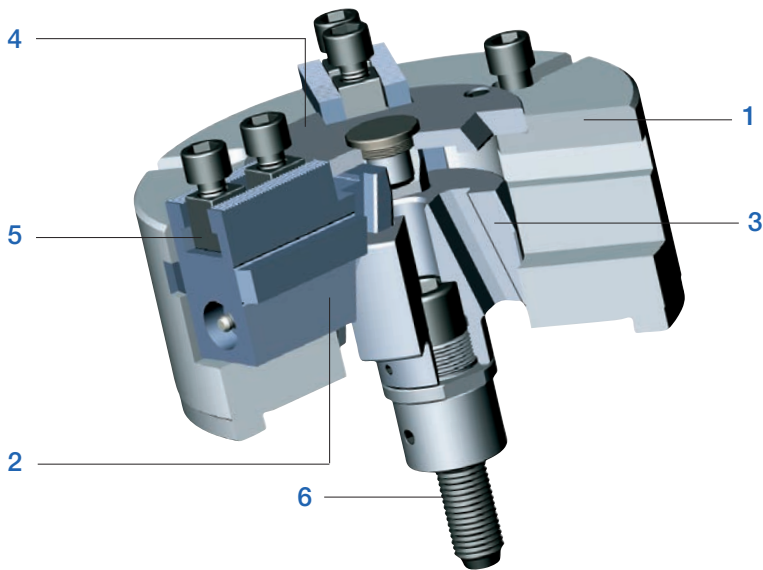

Components KFD

1. Body
2. Base jaw
3. Piston
4. Cover
5. T-nut
6. Draw bolt

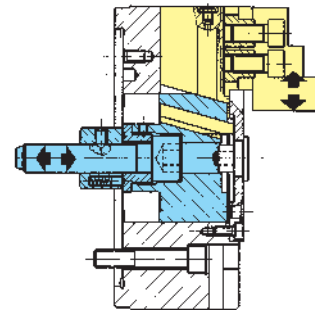

Design principle wedge system

On request:

KFD in customized version (with additional seal)

Power chuck without through-hole KFD

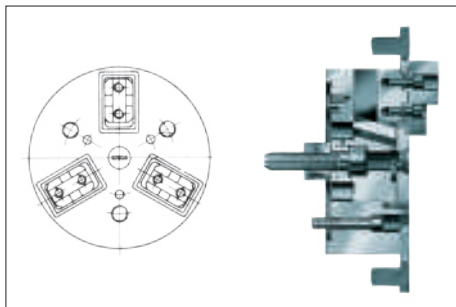

Type 538-40
Hermetically sealed for stationary attachment. Installation in transfer lines and rotary table machines

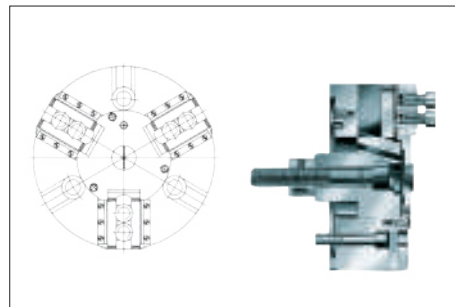

Type 538-42
Largely sealed with wiper blades. Mounting on lathes.

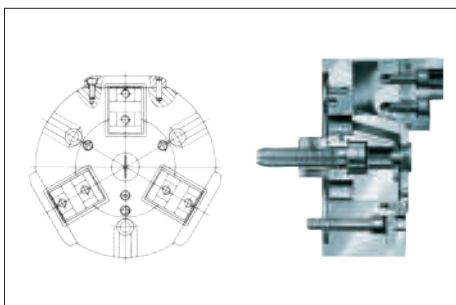

Type 538-41
Hermetically sealed for stationary or rotary attachment. Installation in transfer lines and rotary table machines in minimum amount of space.

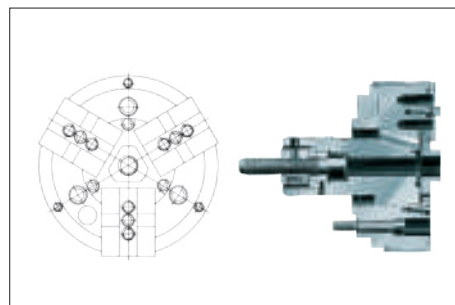

Type 538-43
Hermetically sealed for especially high chip and coolant accumulation on automats or production machines, rotating or stationary.



APPLICATION

Standard power chuck without through-hole for various clamping tasks.

TYPE

Power chuck available with cylindrical centre mount.
 3-jaw version with serration 90° or tongue and groove.
 2-jaw and 3-jaw version with serration 90° and weight reduction.

CUSTOMER BENEFITS

- ⊕ Long service life - all moving parts are hardened and ground
- ⊕ High clamping precision thanks to proven wedge hook system

TECHNICAL FEATURES

- Power transmission by means of powerfully dimensioned wedge hook system
- Direct lubrication of the base jaws
- Starting from size 200 with roller for limiting the jaw movement
- The forward movement of the piston is stopped in the cylinder, movement toward the rear is stopped at the spindle or spindle flange

Included in the scope of delivery: tongue and groove

Chuck, chuck and jaw mounting screws (without top jaws)

Included in the scope of delivery: serration

Chuck, chuck and jaw mounting screws, slot nuts (without top jaws)



Gripping force/speed diagrams

The loss of gripping force was determined experimentally on a chuck with matched UB top jaws. It is largely independent of the initial gripping force at zero speed.

Upper curve:
min. centrifugal force of top jaw



Lower curve:
max. centrifugal force of top jaw



To obtain the specified gripping forces, the chuck must be in a perfect condition and lubricated with F 80 lubricant recommended by RÖHM. Measuring point near chuck face.

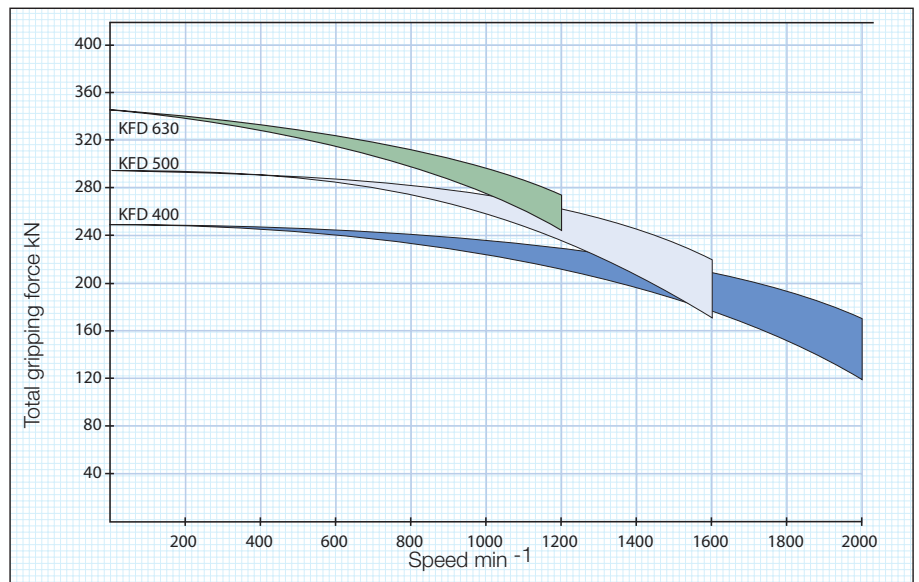
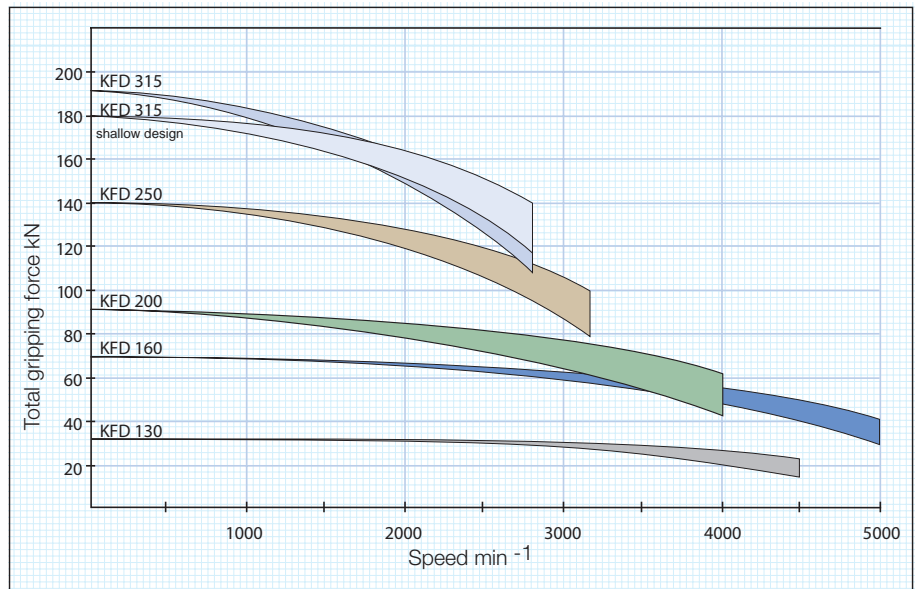

Power chuck without through-hole KFD

KFD 3-jaw, standard design, serration 90°

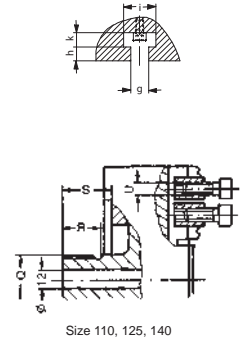
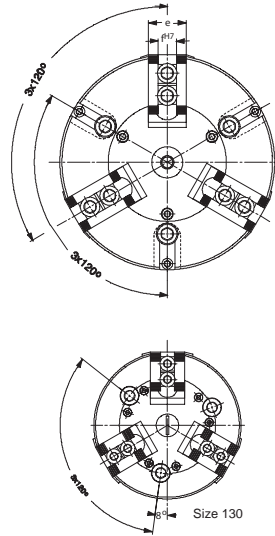
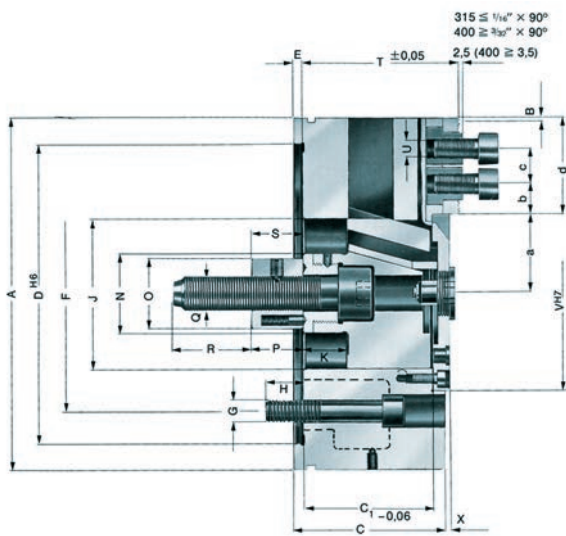

Size 110, 125, 140

C15

3-jaw power chuck, standard design, serration 90°, Cylindrical centre mount, mounting dimensions to DIN 6353

Item No.	004250	128405 ¹⁾	041240	023520	040630	144598	040653	040660 ▲	040669 ▲	040676 ▲
Size	110	125	130	160	200	250	315	400	500	630
A mm	110	125	130	160	200	250	315	400	500	630
Jaw travel B mm	2,1	3,7	5,3	5,3	6,7	6,7	8	9,3	9,3	10,5
C mm	31,5	40	69	79	87	102	117	127	127	140
C1 _{-0,05} mm	28,55	37,05	58,05	66,05	74,05	89,05	104,05	111,05	111,05	125,05
Mount D ^{H6}	92	105	115	140	170	220	300	300	380	380
E mm	3	3	6	6	6	6	6	6	6	8
F mm	80	80	85	104,8	133,4	171,4	235	235	330,2	330,2
G mm	3 x M 8	3 x M 8	3 x M 10	3 x M 10	3 x M 12	3 x M 16	3 x M 20	3 x M 20	6 x M 24	6 x M 24
H mm	12	14	15	17	20	26	30	35	35	35
J mm	45	50	58	65	85	105	120	155	155	180
Wedge stroke K mm	8	14	20	20	25	25	30	35	35	40
N mm	-	-	35	35	45	55	60	60	60	80
O mm	-	-	34	34	40	46	46	55	55	55
P mm	-	-	25	25	30	30	30	30	30	30
Q mm	M20x1,5	M20x1,5	M 16	M 16	M 20	M 24	M 24	M 24	M 30	M 30
R mm	20	20	40	40	45	55	55	55	55	63
S min.	25	25	36	25	30	30	30	30	30	28
S max.	33	39	56	45	55	55	60	65	65	68
T ^{+0,05} mm	34	44	73	80	90	105	120	130	130	148
U	M 6 x 18	M 6 x 18	M 8 x 20	M 12 x 25	M 12 x 25	M 16 x 30	M 16 x 30	M 20 x 40	M 20 x 40	M 20 x 40
V ^{H7} mm	-	-	85	85	110	130	160	190	190	220
X mm	4	6	5	3	3	3	3	3	3	6
a min.	23,9	24,3	25	26,7	38,3	48,3	54	72,7	72,7	85,2
a max.	26	28	30,3	32	45	55	62	82	82	95,7
b min.	8,2	7	6	9	8	10	10	14	14	18
c min.	10	10	14	19	19	25	25	31	31	31
c max.	14,8	25	26	36,5	44,5	58,5	81,5	98	148	197
d mm	28	34,5	34,5	48	55	70	95	118	164	219,3
e mm	25	25	30	35	35	50	55	60	60	70
f ^{H7} mm	10	10	12	17	17	21	21	25,5	25,5	25,5
g mm	-	-	-	14	14	18	18	22	22	22
h mm	-	-	-	11	11	13	13	22	22	22
i mm	-	-	-	25	25	32	32	40	40	40
k mm	-	-	-	11	11	14	14	18	18	18
Max. swing top jaws mm	172	192	184	215	290	345	410	560	660	790
Maximum draw bar pull kN	7	9	18	35	45	65	80	95	110	130
Max. total clamping force kN	12	15	35	70	90	140	190	250	300	360
Max. admissible speed min ⁻¹	4000	5000	5000	4500	4000	3200	2800	2000	1600	1200
Moment of inertia J kgm ²	0,003	0,007	0,014	0,035	0,095	0,28	0,87	1,96	4,31	13,4
Weight without jaws approx. kg	2,1	3,6	6,8	10,9	19	35,5	70	98	138	270
Actuating cylinders (recommended)	OVS-85	OVS-85	OVS-85	OVS-105	OVS-130	OVS-150	OVS-150	OVS-200	OVS-200	OVS-200

¹⁾ Shallow design

KFD 3-jaw, standard design, tongue and groove

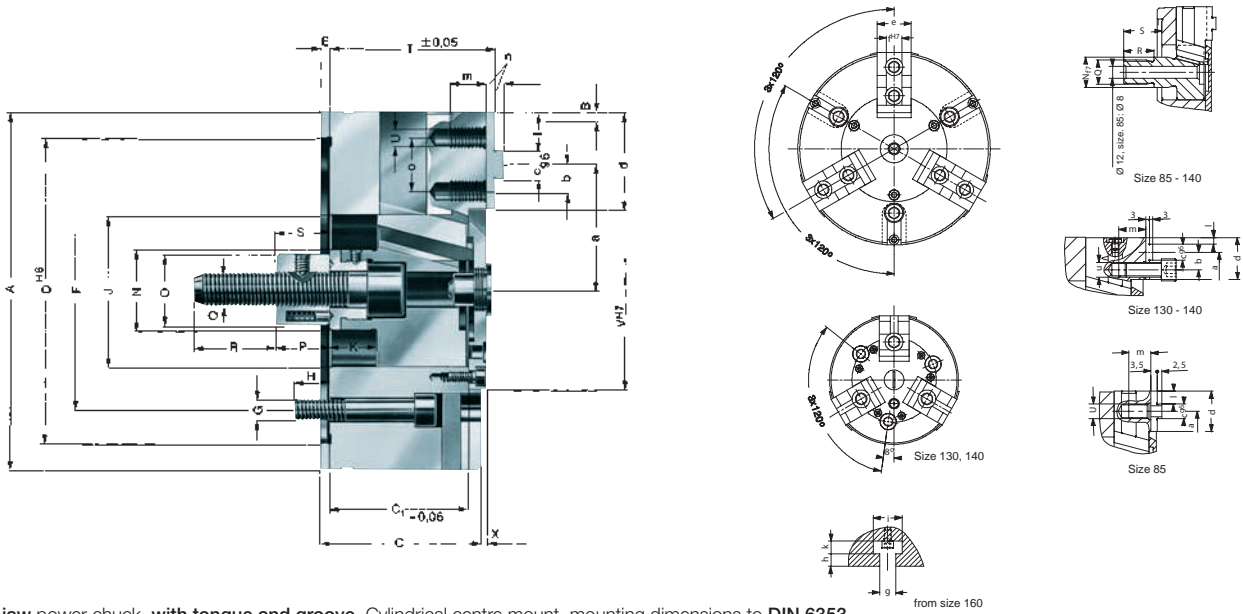

3-jaw power chuck, with tongue and groove, Cylindrical centre mount, mounting dimensions to DIN 6353

Item No.	123110	004266	128427 ¹⁾	023529	040639 ▲	144604 ▲	144605 ▲
Size	85	110	125	160	200	250	315
A mm	85	110	125	160	200	250	315
Jaw travel B mm	2,6	2,1	3,7	5,3	6,7	6,7	6,7
C mm	31,5	31,5	40	79	87	102	102
C1 _{-0,06} mm	28,55	28,55	37,05	66,05	74,05	89,05	89,05
Mount D ^{H6}	70	92	105	140	170	220	220
E mm	3	3	3	6	6	6	6
F mm	54	80	80	104,8	133,4	171,4	171,4
G mm	3 x M8	3 x M8	3 x M8	3 x M10	3 x M12	3 x M16	3 x M16
H mm	12	12	14	17	20	26	26
J mm	36	45	50	65	85	105	105
Wedge stroke K mm	10	8	14	20	25	25	25
N mm	20	-	-	35	45	55	55
O mm	-	-	-	34	40	46	46
P mm	-	-	-	25	30	30	30
Q mm	M16 x 1,5	M20 x 1,5	M20 x 1,5	M16	M20	M24	M24
R mm	20	20	20	40	45	55	55
S min.	25	25	25	25	30	30	30
S max.	35	33	39	45	55	55	55
T ^{+0,05} mm	33	33	44	80	90	105	105
U	M8	M6	M6	M12	M12	M16	M16
V ^{H7} mm	-	-	-	85	110	130	130
X mm	4	4	6	3	3	3	3
a min.	29,4	37,9	40,3	46,7	63,3	81,3	93,3
a max.	32	40	44	52	70	88	100
b mm	-	7,5	7,5	12,5	15	20	25
cg6 mm	8	8	8	10	12	16	16
d mm	22	28	34,5	48	55	70	102
e mm	20	25	25	35	35	50	50
f ^{H7} mm	8	8	8	16	16	20	20
g mm	-	-	-	14	14	18	18
h mm	-	-	-	11	11	13	13
i mm	-	-	-	25	25	32	32
k mm	-	-	-	11	11	14	14
l mm	7	10	12,75	23	24	29	49
m mm	14	12	12	20	20	25	25
n mm	2,5	2,5	3	5	5	5	5
o mm	-	15	15	25	30	40	50
Maximum draw bar pull kN	7	7	9	35	45	65	75
Max. total clamping force kN	12	12	15	70	90	140	180
Max. admissible speed min ⁻¹	5000	4000	5000	4500	4000	3200	2800
Moment of inertia J kgm ²	0,001	0,003	0,007	0,035	0,096	0,28	0,73
Weight without jaws approx. kg	1,3	2,1	3,7	11	19,2	36	59
Actuating cylinders (recommended)	OVS-85	OVS-85	OVS-85	OVS-105	OVS-130	OVS-150	OVS-150

¹⁾ Shallow design

Power chuck without through-hole KFD

KFD 3-jaw, weight reduced, serration 90°

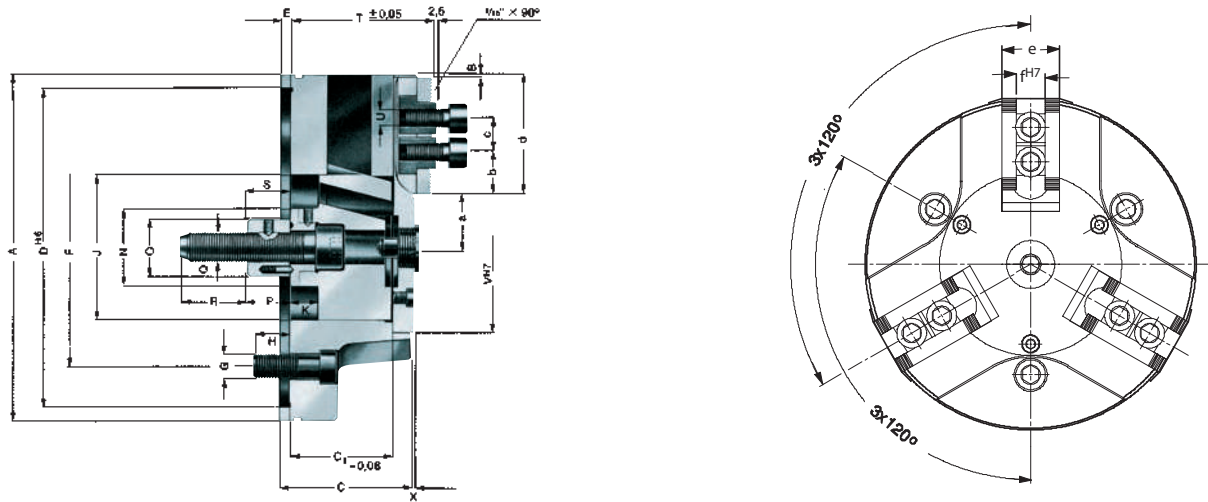

3-jaw power chuck, weight reduced, serration 90°
Cylindrical centre mount, mounting dimensions to DIN 6353

Item No.	046730	046744 ▲	144594 ▲	144596
Size	160	200	250	315
A mm	160	200	250	315
Jaw travel B mm	5,3	6,7	6,7	6,7
C mm	79	87	102	102
C1 _{-0,06} mm	66,05	74,05	89,05	89,05
Mount D ^{H6}	140	170	220	220
E mm	6	6	6	6
F mm	104,8	133,4	171,4	171,4
G mm	3 x M 10	3 x M 12	3 x M 16	3 x M 16
H mm	17	20	26	26
J mm	65	85	105	105
Wedge stroke K mm	20	25	25	25
N mm	35	45	55	55
O mm	34	40	46	46
P mm	25	30	30	30
Q mm	M16	M20	M24	M24
R mm	40	45	55	55
S min.	25	30	30	30
S max.	45	55	55	55
T ^{+0,05} mm	80	90	105	105
U	M 12 x 25	M 12 x 25	M 16 x 30	M 16 x 30
V ^{H7} mm	85	110	130	130
X mm	3	3	3	3
a min.	26,7	38,3	48,3	48,3
a max.	32	45	55	55
b min.	9	8	10	10
c min.	19	19	25	25
c max.	36,5	44,5	58,5	89,5
d mm	48	55	70	102,5
e mm	35	35	50	50
f ^{H7} mm	17	17	21	21
Max. swing top jaws mm	215	290	345	410
Maximum draw bar pull kN	35	45	65	75
Max. total clamping force kN	70	90	140	180
Max. admissible speed min ⁻¹	4500	4000	3200	2800
Moment of inertia J kgm ²	0,027	0,076	0,226	0,496
Weight without jaws approx. kg	8,5	15,2	29	40
Actuating cylinders (recommended)	OVS-105	OVS-130	OVS-150	OVS-150

KFD 2-jaw, weight reduced, serration 90°

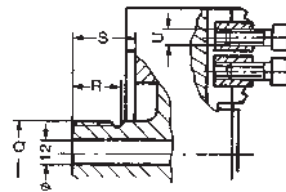
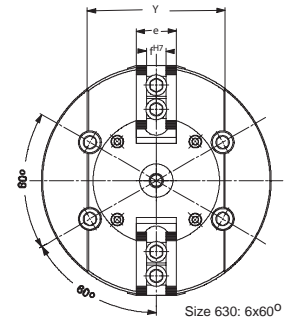
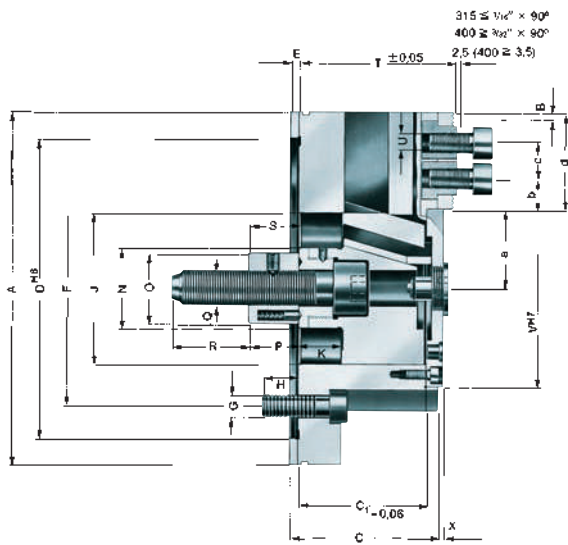

2-jaw power chuck, weight reduced, serration 90°
Cylindrical centre mount, mounting dimensions to DIN 6353

Item No.	128409 ¹⁾	046736 ▲	046750 ▲	144608	045566	128421	128422 ▲	128423 ▲
Size	125	160	200	250	315	400	500	630
A mm	125	160	200	250	315	400	500	630
Jaw travel B mm	3,7	5,3	6,7	6,7	8	9,3	9,3	10,5
C mm	40	79	87	102	117	127	127	140
C1 _{±0,06} mm	37+0,07	66,05	74,05	89,05	104,05	111,05	111,05	125,05
Mount D ^{H6}	105	140	170	220	300	300	380	380
E mm	3	6	6	6	6	6	6	8
F mm	80	104,8	133,4	171,4	235	235	330,2	330,2
G mm	4xM8	4 x M10	4 x M12	4 x M16	4 x M20	4 x M20	4 x M24	6 x M24
H mm	14	17	20	26	26	35	35	35
J mm	50	65	85	105	120	155	155	180
Wedge stroke K mm	14	20	25	25	30	35	35	40
N mm	-	35	45	55	60	60	60	80
O mm	-	34	40	46	46	55	55	55
P mm	-	25	30	30	30	30	30	30
Q mm	M20x1,5	M16	M20	M24	M24	M24	M30	M30
R mm	20	40	45	55	55	55	55	63
S min.	25	25	30	30	30	30	30	28
S max.	39	45	55	55	60	65	65	68
T ^{±0,05} mm	44	80	90	105	120	130	130	148
U	M6x8	M12 x 25	M12 x 25	M16 x 30	M16 x 30	M20 x 40	M20 x 40	M20 x 40
V ^{H7} mm	-	85	110	130	160	190	190	220
X mm	6	3	3	3	3	3	3	6
a min.	24,3	26,7	38,3	48,3	54	72,7	76,7	85,2
a max.	28	32	45	55	62	82	86	95,7
b min.	7	9	8	10	10	14	16	18
c min.	10	19	19	25	25	31	31	31
c max.	25	36,5	44,5	58,5	81,5	98	144	197
d mm	34,5	48	55	70	95	118	164	219,3
e mm	25	35	35	50	55	60	60	70
f ^{H7} mm	10	17	17	21	21	25,5	25,5	25,5
Y mm	-	95	120	140	170	220	240	265
Max. swing top jaws mm	192	215	290	345	410	560	660	790
Maximum draw bar pull kN	6	23	30	43	55	65	75	90
Clamping force/jaw kN	6,5	25	33	48	62	75	85	120
Max. admissible speed min ⁻¹	5000	4500	4000	3200	2800	2000	1600	1200
Moment of inertia J kgm ²	0,007	0,027	0,075	0,222	0,62	1,92	5,31	12,9
Weight without jaws approx. kg	3,6	8,5	15	28,5	53	96	170	200
Actuating cylinders (recommended)	OVS-85	OVS-85	OVS-105	OVS-130	OVS-130	OVS-150	OVS-200	OVS-200

¹⁾ Chuck without weight reduction

Power chuck without through-hole KFD

Jaws KFD

C 21

Reversible top jaws, hardened, serration 90° - material: 16MnCr5

Chuck Size	2-jaw set	3-jaw set	Jaw length mm	Jaw height mm	Jaw width mm	Serration
110/125	046545	046544	56	37,5	26	1/16"x 90°
130	045796	046404	56	37,5	26	1/16"x 90°
160/200	046429	046408	68	45	34,7	1/16"x 90°
160/200/250	118521	118522	75	49	36	1/16"x 90°
250/315	046435	046414	103,5	58	50	1/16"x 90°
400/500/630	046447	037531	135	65	68	3/32"x 90°

Additionally or later applied, hardened jaws must be ground out in the chuck.

C 21

Soft top jaws, can be hardened, serration 90° - material: 16MnCr5

Chuck Size	2-jaw set	3-jaw set	Jaw length mm	Jaw height mm	Jaw width mm	Serration
110/125	045794	046402	53	30	22,5	1/16"x 90°
130	045795	046403	55	38	26,5	1/16"x 90°
160	133147	133152	66,7	53	36,5	1/16"x 90°
200	133148	133153	75	53	36,5	1/16"x 90°
250	133149	133154	95	54,5	45	1/16"x 90°
315	133150	133155	103	80	50	1/16"x 90°
400/500/630	133151	133156	130	80	50	3/32"x 90°
400/500/630	046446	046423 ¹⁾	130	89	68	3/32"x 90°

C 21

Soft top jaws, can be hardened, tongue and groove 120° bevelled - material: 16MnCr5

Chuck Size	3-jaw set	Jaw length mm	Jaw height mm	Jaw width mm
85	119459	40	30	22,5
110/125	046859	51	30	22,5
160	123358	72,7	53	36,5
200	123430	90,3	53	36,5
250	123433	115,3	54,5	45
315	129849	146	80	50

C 21

Claw-type jaws, 1 piece, hardened, serration 90° - width of the groove 12

Item no.	Chuck Size	Jaw length mm	Jaw height mm	Claw length mm	Serration
144320	130	66	38	52	1/16"x 90°
144321	130	56	38	34	1/16"x 90°
144322	130	66	38	25	1/16"x 90°

C 21

Claw-type jaws, 1 piece, hardened, serration 90° - width of the groove 17

Item no.	Chuck Size	Jaw length mm	Jaw height mm	Claw length mm	Serration
137031	160/200	67	45	53	1/16"x 90°
137032	160/200	65	45	46	1/16"x 90°
137039	160/200	55	45	40	1/16"x 90°
137034	160/200	50	45	31	1/16"x 90°
137035	160/200	55	45	27	1/16"x 90°
137036	160/200	65	45	19	1/16"x 90°
137037	160/200	65	45	26	1/16"x 90°
137038	160/200	55	45	24	1/16"x 90°
137033	160/200	55	45	39	1/16"x 90°

Jaws KFD

C 21

Claw-type jaws, 1 piece, hardened serration 90° - width of the groove 21



Item no.	Chuck Size	Jaw length mm	Jaw height mm	Claw length mm	Serration
137041	250/315	95	50	80	1/16"x 90°
137042	250/315	75	50	60	1/16"x 90°
137043	250/315	60	50	43	1/16"x 90°
137044	250/315	70	50	37	1/16"x 90°
137045	250/315	95	50	25	1/16"x 90°
137046	250/315	80	50	30	1/16"x 90°

C 21

Claw-type jaws, 1 piece, hardened serration 90° - width of the groove 25,5



Item no.	Chuck Size	Jaw length mm	Jaw height mm	Claw length mm	Serration
137051	400/500/630	130	65	113	3/32"x 90°
137052	400/500/630	90	65	67	3/32"x 90°
137053	400/500/630	100	65	45	3/32"x 90°
137054	400/500/630	130	65	33	3/32"x 90°

Accessories KFD

C 15 T-nuts

With screw

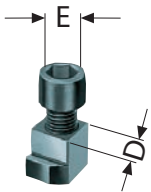

Item no.	Chuck Size	Contents of delivery	D mm	E
1305163	110/125	piece	10	M6x18
241673 ¹⁾	130	piece	12	M8x20
241674	160/200	piece	17	M12x25
241675	250	piece	21	M16x30
241676 ¹⁾	400/500/630	piece	25,5	M20x40

¹⁾ Metric dimensions

C 15 **Special grease F80 for lathe chucks**

for lubrication and conservation of clamping force



Item no.	Design	Contents
308555	Cartridge	0,5 kg
028975	Tin	1 kg

C15 Grease gun DIN1283



Item no.	Connection	Contents of delivery
329093	M10x1	150 mm nozzle tube bent, needlepoint mouthpiece, top mouthpiece, 300 mm high pressure hose with 4 jaw hydraulics cross mouthpiece

Accessories KFD

C 15

Intermediate adaptor plates with cylindrical centre mount DIN 6353 for 3-jaw chucks

Mounting from front to ISO 702-1 (DIN 55026/55021) and ASA B 5.9 A1/A2 with metric mounting bolts

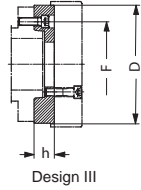
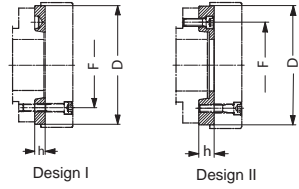

Item no.	Spindle nose size	Size	Design	h mm	F mm	D mm
145125 ¹⁾	4	160	II	18	82,6	140
145153	5	175	I	15	104,8	140
145127	5	200	II	21	104,8	170
145129	6	160	III	35	133,4	140
145155	6	200	I	16	133,4	170
145131	6	250	II	27	133,4	220
145135	8	200	III	39	171,4	170
145157	8	250	I	18	171,4	220
145137▲	8	315/400	II	38	171,4	300
145141	8	500/630	II	38	171,4	380
145143▲	11	250	III	48	235	220
145159	11	315/400	I	19	235	300
145145▲	11	500/630	II	40	235	380
145149	15	400	III	58	330,2	300
145161	15	400/500/630	I	21	330,2	380

¹⁾ DIN 55021 on request

All fastening parts are included

Intermediate adaptor plate for 2-jaw version on request

Jaw dimensions KFD / KFD-EC

Reversible top jaw UB,
hardened, serration 90°

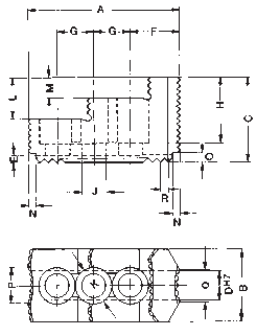

Chuck size	110/125/140	130	160	200/250 ¹⁾	250/315	400-800
Type	537-02	538-02	538-03	538-04	538-05	538-07 ²⁾
Item no. 2-jaw set	046545	045796	046429	118521	046435	046447
Item no. 3-jaw set	046544	046404	046408	118522	046414	037531
A	56	56	68	75	103,5	135
B	26	26	34,7	36	50	68
C	37,5	37,5	45	49	58	65
DH7	10	12	17	17	21	25,5
E	3,5	3,5	5	5	5	5
F	10	14	17	21,5	33,5	48
G	12 ³⁾	15	19	19	25	31
H	29	29	33,5	37,5	45	48
J	6,4	8,4	13	13	17	21
K	10,4	13,5	19	19	25	31
L	20	20	20	24	28	-
M	10	10	10	12	14	26
N	4	4	5	6	6	6,5
O	4	4	7	7,5	6,5	5,5
P	5	5	10	18	24,5	34
Q	5	5	5	7	22,5	40
R	1/16"x90°	1/16"x90°	1/16"x90°	1/16"x90°	1/16"x90°	3/32"x90°
Weight/jaw kg	0,130	0,170	0,350	0,460	1,130	2,000

1) Size 250: chuck in shallow design

2) One step only

3) 4 mounting holes

Soft top jaws AB,
serration 90°, module toothing
(size 1000-1600)

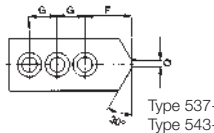
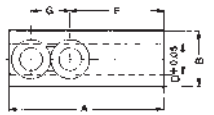
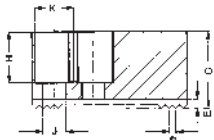

Type 537-02
Type 543-22

Chuck size	110/125/140	130	160	200/250 ¹⁾	250	315	400-800	400-800
Type	537-02	538-02	538-03	538-04	538-05	538-06	538-07	538-07 ²⁾
Item no. 2-jaw set	045794	045795	133147	133148	133149	133150	133151	046446
Item no. 3-jaw set	046402	046403	133152	133153	133154	133155	133156	046423
A	53	55	66,7	75	95	103	130	130
B	22,5	26,5	36,5	36,5	45	50	50	68
C	30	38	53	53	54,5	80	80	89
D	10	12	17	17	21	21	25,5	25,5
E	3,5	3,5	5	5	5	5	5	5
F	20	31	36	44	55	62	79	75
G	12 ³⁾	15	19	19	25	25	31	35
H	20	28	43	43	42,5	67	60	69
J	6,4	8,4	13	13	17	17	21	21
K	10,4	13,5	19	19	25	25	31	31
Q	3	-	-	-	-	-	-	-
R	1/16"x90°	1/16"x90°	1/16"x90°	1/16"x90°	1/16"x90°	1/16"x90°	3/32"x90°	3/32"x90°
Weight/jaw kg	0,223	0,320	0,700	0,880	1,400	2,580	3,1	5,120

1) Size 250: chuck in shallow design

2) Heavy design

3) 3 mounting holes

Soft top jaws AB,
tongue and groove

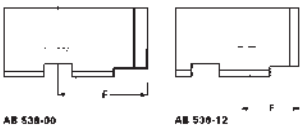
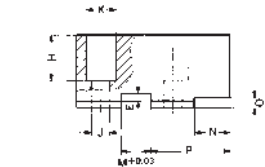

AB 538-00

AB 539-12

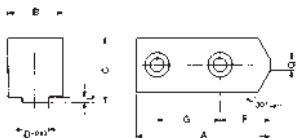

Chuck size	85	110/125 ¹⁾	160	200	250	315
Type	538-00	537-03	538-13	538-14	538-15	538-66
Item no. 3-jaw set	119459	046859	123358	123430	123433	129849
A	40	51	72,7	90,3	115,3	146
B	22,5	22,5	36,5	36,5	45	50
C	30	30	53	53	54,5	80
D _{0,03}	8	8	16	16	20	20
E	3	3,5	5,5	5,5	5,5	5,5
F	29	29,5	32,5	45,3	58,3	63,5
G	-	15	25	30	40	50
H	20	20	38	38	38	60
J	9	6,4	13	13	17	17
K	15	10,4	19	19	25	25
L	2,5	2,5	4,5	4,5	4,5	4,5
M _{0,03}	8	8	10	12	16	16
N	18	23	24,7	35,3	45,3	43
O	4	4	5	5	5	5
P	25	33	39,7	54,3	70,3	80,5
Q	3	3	3	6	6	6
Weight/jaw kg	0,146	0,200	0,720	1,000	1,550	3,600

1) Chuck in shallow design

Jaw dimensions KFD / KFD-EC

Claw type jaws KB,
Serration 90°

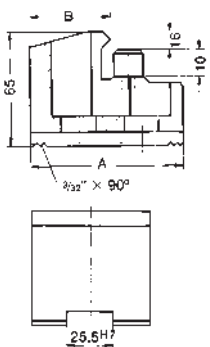
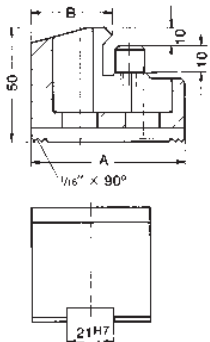
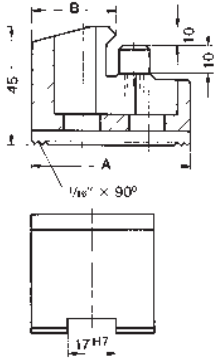
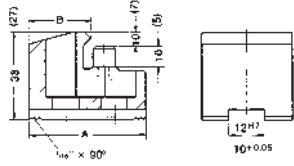

Size	A	B	130 External chucking
Item no. piece			
144320	66	52	38-82
144321	56	34	78-122
144322	66	25	120-144
			Internal chucking
144322	66	25	70-98
144321	56	34	92-138
144320	66	52	122-178

Size	A	B	160 External chucking	200 External chucking
Item no. piece				
137031	67	53	38-56	60-96
137032	65	46	51-71	73-111
137039	55	40	66-87	88-127
137034	50	31	83-102	105-142
137035	55	27	97-117	119-157
			Internal chucking	
137036	65	19	50-70	72-110
137037	65	26	68-85	90-125
137038	55	24	82-104	104-144
137035	55	27	102-116	124-156
137034	50	31	114-123	136-163
137039	55	40	120-135	144-175
137033	55	39	132-165	154-205
137032	65	46	146-178	168-218

Size	A	B	250 External chucking	315 ¹⁾ External chucking	315 External chucking
Item no. piece					
137041	95	80	53-95	53-160	66-160
137042	75	60	92-133	92-198	105-198
137043	60	43	125-167	125-232	138-232
137044	70	37	156-198	156-263	169-263
			Internal chucking		
137045	95	25	68-112	68-117	81-177
137046	80	30	108-154	108-219	121-219
137044	70	37	146-186	146-240	159-240
137043	60	43	178-240	178-305	191-305
137042	75	60	212-265	212-330	225-330

1) Chuck in shallow design

Size	A	B	400 External chucking	500 External chucking	630 External chucking
Item no. piece					
137051	130	113	80-180	80-280	114-410
137052	90	67	170-270	170-370	204-500
137053	100	45	256-390	270-495	290-625
			Internal chucking		
137054	130	33	100-215	100-315	134-445
137053	100	45	260-395	275-500	295-625
137051	130	113	300-460	300-560	334-690

Chucking capacities KFD

Chucking capacities with reversible top jaw UB/AB for 2- and 3-jaw chucks

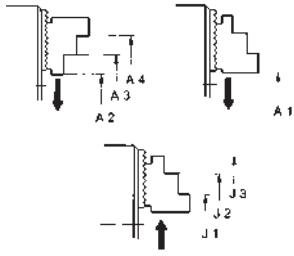

Chuck size		110	125	130	140	160	200	250 1)	250	315 1)	315	400	500	630
with reversible jaws	Type	537-02	537-02	538-02	537-02	538-03	538-04	538-04	538-05	538-05	538-05	538-07	538-07	538-07
	Jaw position													
External chucking	A1	4-62	4-78	6-66	4-93	5-73	16-108	16-159	20-124	20-189	34-189	40-225	40-325	60-450
	A2	-	-	-	-	-	28-118	28-169	38-152	38-217	52-217	70-280	70-380	108-510
	A3	47-105	75-126	60-119	75-140	70-140	86-173	86-223	120-232	120-297	134-297	-	-	-
	A4	82-140	110-161	94-151	110-176	110-182	137-224	137-274	200-314	200-379	214-379	275-480	275-580	310-700
Internal chucking	J1	40-95	40-110	42-96	40-125	53-120	70-156	70-208	70-170	70-233	84-233	102-305	102-405	136-530
	J2	74-130	72-145	74-130	72-160	92-163	120-208	120-258	146-251	146-313	160-313	-	-	-
	J3	112-168	116-190	118-175	116-205	144-200	173-261	173-311	236-328	236-393	250-393	295-490	295-590	328-720

1) Chuck in shallow design

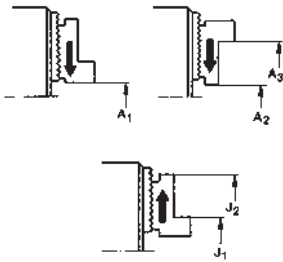

KFD-G - large jaw stroke



APPLICATION

Power chuck without through-hole for clamping workpieces with collars or shoulders (e.g. fittings), without having to give up high clamping force.

TYPE

Power chuck is available with cylindrical centre mount.
2-jaw version with serration 90° (sizes 125 + 160 with tongue and groove).

CUSTOMER BENEFITS

- ③ Minimization of the interference contours of the chuck by means of bevels on the chuck body
- ③ Excessively high jaw stroke for flexible chuck use
- ③ Long service life - sealed against dirt and water
- ③ High clamping precision thanks to proven wedge hook system

TECHNICAL FEATURES

- Power transmission by means of wedge hook system
- Direct lubrication of base jaws and pistons (4 lubrication points)
- Full steel design

Included in the scope of delivery: tongue and groove

Chuck, chuck and jaw mounting screws (without top jaws)

Included in the scope of delivery: serration

Chuck, chuck and jaw mounting screws, slot nuts (without top jaws)



Size 125 + 160
Tongue and groove

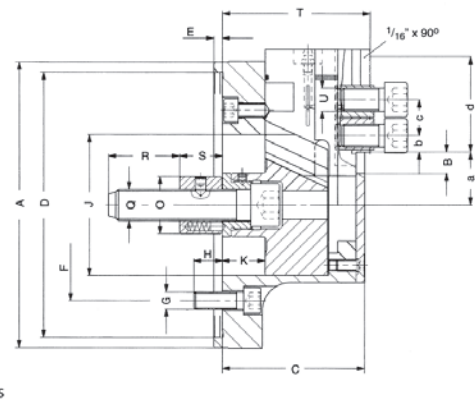
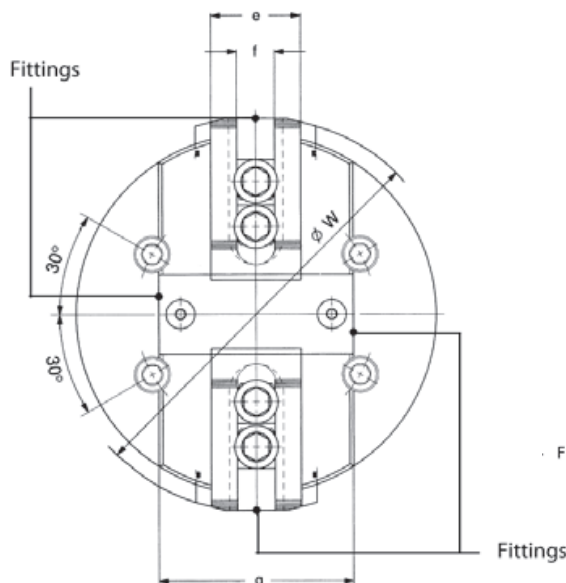
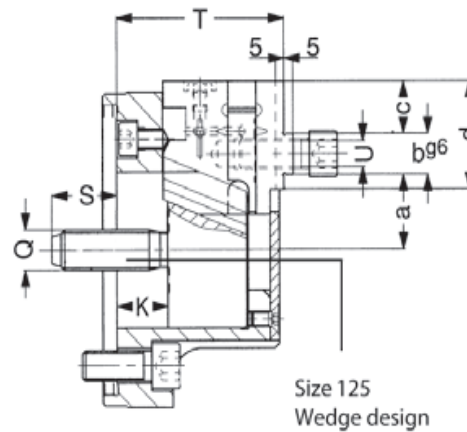
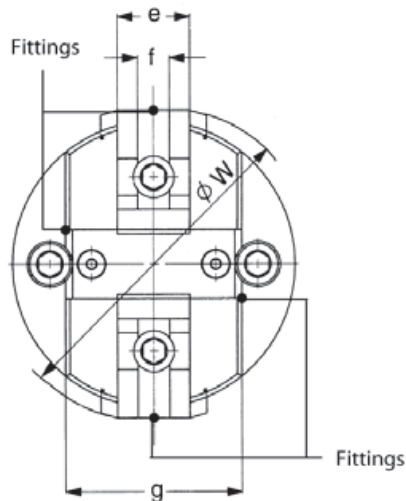

KFD-G 2-jaw, large jaw movement, serration 90°

C15

2-jaw power chuck **KFD-G, with large jaw movement,**
Cylindrical centre mount for clamping workpieces with collars or shoulders (e.g. fittings), without having to give up high clamping force. Full steel design, weight reduction, direct lubricated, special sealing against dirt and water.

Item No.	154025 ▲	154026 ▲	154027 ▲	154028	154029
Size	125	160	200	250	315
A mm	125	160	200	250	315
Jaw travel B mm	8,5	11	14	14,4	14,4
C mm	70	81	100	102	102
Mount D ¹⁶	115	140	185	220	220
E mm	6	6	6	6	6
F mm	92	104,8	133,4	171,4	171,4
G mm	2 x M 12	4 x M 10	4 x M 12	4 x M 16	4 x M 16
H mm	15	16	20	25	25
J mm	62	75	98	98	98
Wedge stroke K mm	22	27	30	31	31
O mm	-	35	44	44	44
Q mm	M 16	M 16	M 22	M 22	M 22
R mm	-	40	50	50	50
S min.	28	33	30	29	29
S max.	50	60	60	60	60
T ^{+0,05} mm	72	84	103,7	105,7	105,7
U	M 12	M 16	M 16	M 20	M 20
WMax.	140	180	220	270	334
a min.	21,5	32,5	23	22,6	22,6
a max.	30	43,5	37	37	37
b min.	16g6	18g6	14	14	14
c min.	21	26	25	31	31
c max.	21	26	55,5	77	103
d mm	43	57,5	71,5	96	128,5
e mm	32	35	50	55	55
f ^{H7} mm	14	18	21	25,5	25,5
g mm	78	91	108	120	120
Maximum draw bar pull kN	13	16	35	45	45
Max. total clamping force kN	10	12	25	29	29
Max. admissible speed min ⁻¹	3500	3000	3000	2500	2200
Moment of inertia J kgm ²	0,01	0,04	0,09	0,2	0,4
Weight without jaws approx. kg	5	9	17	25	36,5
Actuating cylinders (recommended)	OVS-85	OVS-85	OVS-105	OVS-130	OVS-130

C 21

Soft top jaws, 2-jaw set, can be hardened tongue and groove for 2-jaw chucks, material: 16MnCr5

Chuck Size	2-jaw set	Jaw length mm	Jaw height mm	Jaw width mm
125	120321	56,5	53	36,5
160	120320	74,5	53	36,5

C 21

Soft top jaws, 2-jaw set, can be hardened serration 90° - material: 16MnCr5

Chuck Size	2-jaw set	Jaw length mm	Jaw height mm	Jaw width mm	Serration
200	120318	94	89	68	1/16"x 90°
200	133149	95	54,5	45	1/16"x 90°
250	120316	110	89	68	1/16"x 90°
315	120073	130	89	68	1/16"x 90°

Special solutions - for power chucks without through-hole



KFD-HS oil - Power chuck with oil bath lubrication

APPLICATION

Ideal for use under extreme operating conditions thanks to hermetic seal against dirt and cooling water as well as no required maintenance, for the most time.

TYPE

2-, 3- or 4-jaw version with serration 90° or tongue and groove. With short taper or cylindrical centrer mount.

CUSTOMER BENEFITS

- Largely maintenance-free thanks to constant lifetime lubrication of all moving parts through oil filling
- Hermetically sealed against dirt and cooling water
- Ideal for high speeds thanks to KFD-HS principle with simultaneously high concentricity and axial run-out

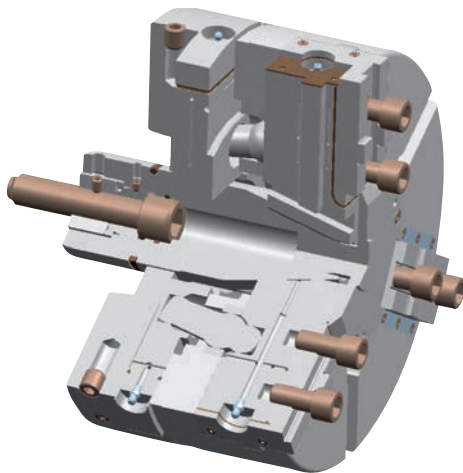

KFD-F-EC - Power chuck with centrifugal force compensation

APPLICATION

Especially for use under extreme operating conditions, e.g. dry or raw part machining and/or high coolant pressure with simultaneous centrifugal force-sensitive clamping.

TYPE

With centrifugal force compensation.

CUSTOMER BENEFITS

- Low-maintenance and -wear thanks to Easy Care
- Centrifugal force compensation for extremely high speeds



MSF - Diaphragm clamping chuck

APPLICATION

Optimally suited for grinding and hard turning with high precision.

TYPE

With quick jaw change system via HSK interface and standard medium feed-through.

CUSTOMER BENEFITS

- Constant, uniform quality and clamping force thanks to diaphragm technology
- Contamination-resistant
- Quick jaw change system via HSK interface for quick jaw change, maximum precision and change accuracy
- Nearly wear-free



Notes

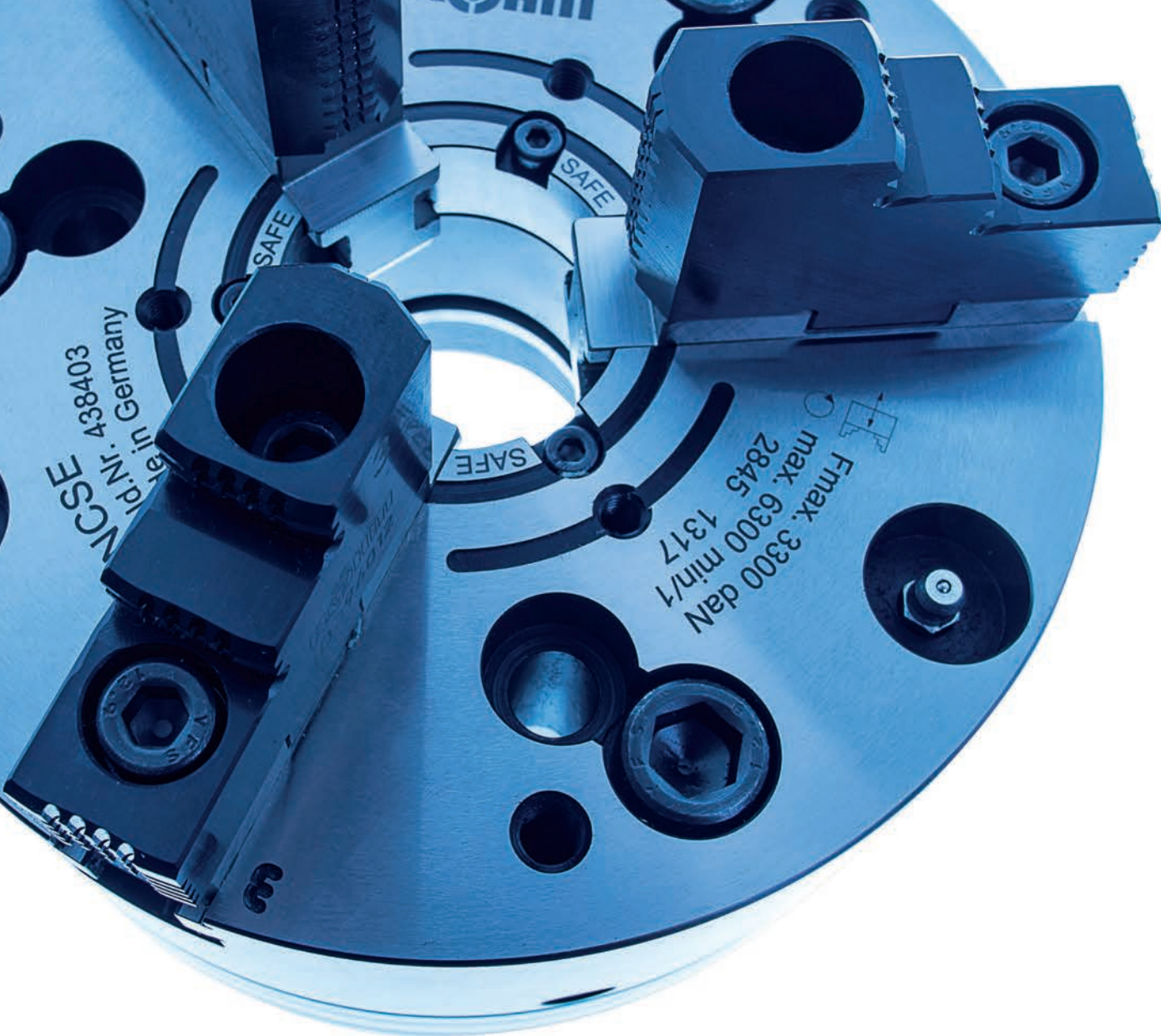

QUICK JAW CHANGE SYSTEM WITH INDIVIDUAL JAW UNLOCKING



The quick jaw change system allows flexible use of the power chuck and drastically reduces set-up times. The jaws can be flexibly offset, turned or changed.

Thanks to the individual jaw unlocking on the DURO-NCSE power chuck, handling with large, workpiece-specific customized top jaws is especially easy: Push the key till stop, then turn in the direction of the arrow.



Video DURO-NCSE



Video DURO-NC

POWER CHUCKS WITH QUICK JAW CHANGE

Fast jaw change, high clamping precision and high clamping force characterize the power chucks DURO-NCSE and DURO-NC. Thanks to the quick jaw change system, the jaws can be flexibly offset, turned or changed. The clamping precision of the chuck is always retained.

ADVANTAGES AT A GLANCE

- ⌚ Flexible use thanks to quick jaw change reducing set-up times
- ⌚ Secure jaw lock via the safety key
- ⌚ Large through-hole optimal for bar machining

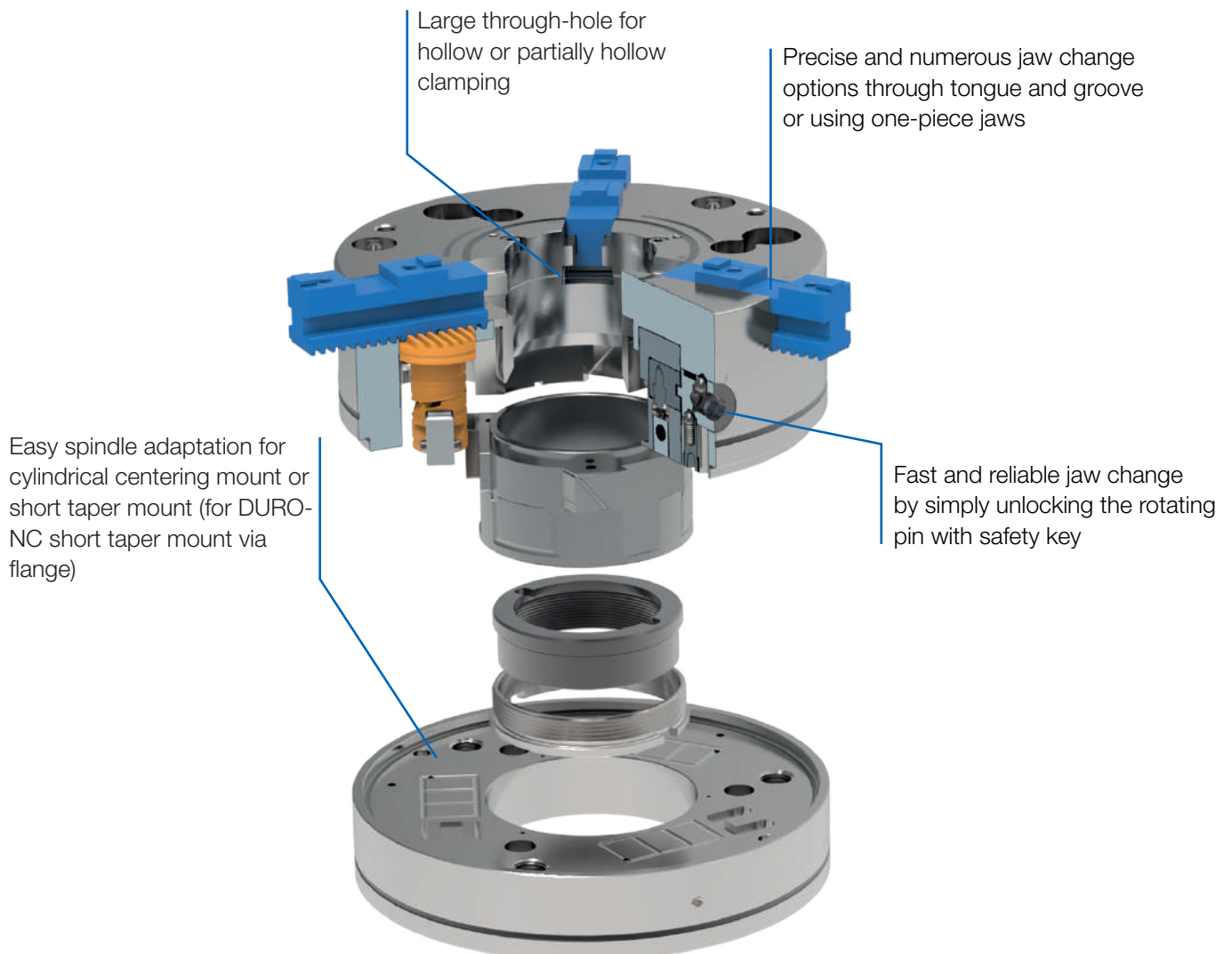

DURO-A RC - jaw change in 50 seconds



APPLICATION

Premium power chuck with through-hole for the machining of bar, pipes and discs. Maximum speeds and flexible use thanks to quick jaw change system with individual jaw unlocking.

TYPE

3-jaw chuck with cylindrical centre mount. Short taper mounting adapter (DIN ISO 702-1) as option.

CUSTOMER BENEFITS

- ⊕ Quick jaw change in 50 seconds
- ⊕ 3-year warranty (pursuant to DURO-A RC warranty)
- ⊕ Excellent price/performance ratio
- ⊕ Overall height reduced by up to 14% and up to 17% weight reduction
- ⊕ High clamping accuracy and clamping force through very stable construction

TECHNICAL FEATURES

- High speeds and optimum centrifugal force behaviour due to low jaw weight and key bar design
- Large through-hole for hollow and partly-hollow clamping
- Base jaws with straight teeth

Included in the scope of delivery:

Chuck, chuck and jaw mounting screws, base jaws, safety wrench, mounting wrench

A RC = Automatic, Rapid, Change



Gripping force / speed diagram

The loss of gripping force was determined experimentally on a chuck with matched UB top jaws. It is largely independent of the initial gripping force at zero speed.

Curve:
max. centrifugal force of top jaw



To obtain the specified gripping forces, the chuck must be in a perfect condition and lubricated with F 80 lubricant recommended by RÖHM. Measuring point near chuck face.

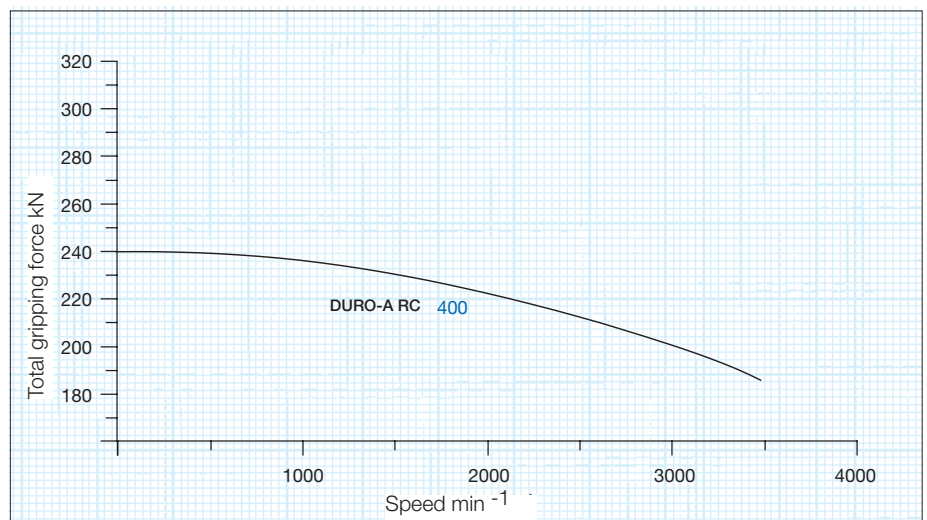
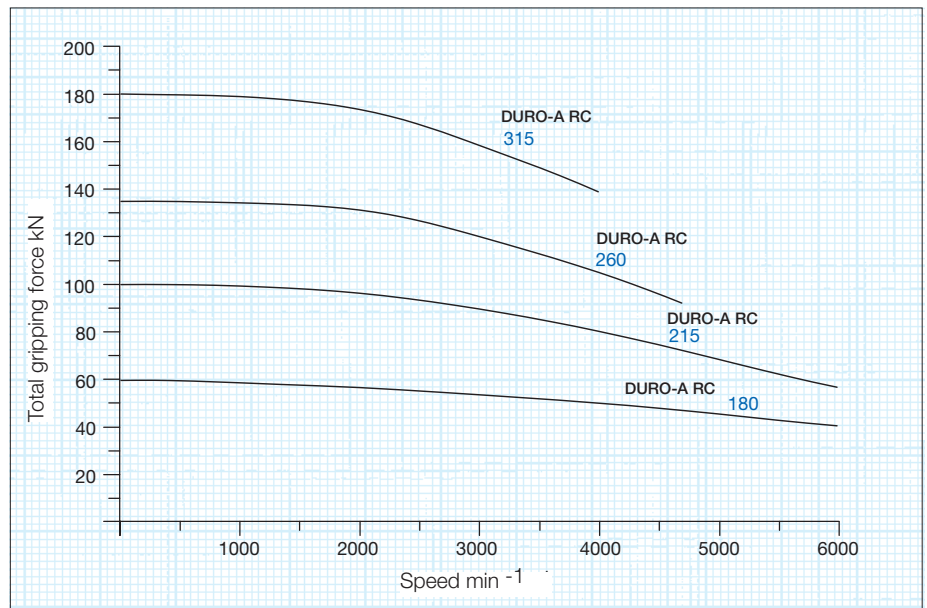

Quick jaw change system with individual jaw unlocking

The individual locking arrangement means that handling is particularly easy with special large jaw pads when the workpiece requires them: push key till stop, then turn in arrow direction.



DURO-A RC 3-jaw, individual jaw unlocking, straight teeth

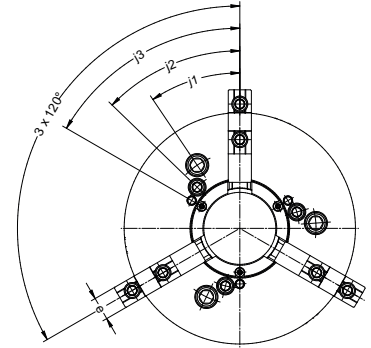
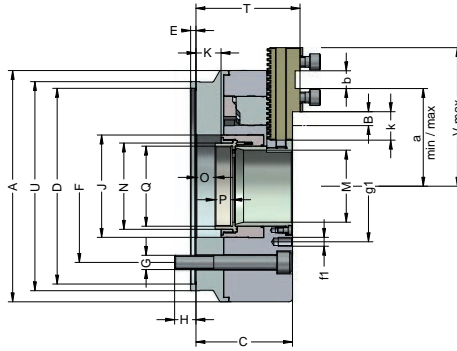
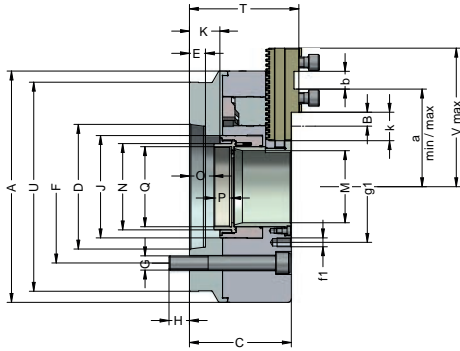

C 15
3-jaw power chucks DURO-A RC with quick jaw change system, with individual jaw unlocking, with straight teeth, Cylindrical centre mount DIN ISO 702-4

Item No.	183100	183101	183104	183106	183107	183108	183111	183112	183114	183115
Size A mm	180	180	215	215	260	260	315	315	400	400
Jaw travel B mm	6,8	6,8	7,4	7,4	8,2	8,2	8,8	8,8	9,4	9,4
C mm	83,9	83,9	95,9	113,9	108,5	108,5	117,7	117,7	125,7	125,7
D mm	ZA 140	ZA 170	ZA 170	KK8	ZA 170	ZA 220	ZA220	ZA 300	ZA 300	ZA 380
E mm	6	6	6	18	6	6	6	6	6	6
F mm	104,8	133,4	133,4	171,4	133,4	171,4	171,4	235	235	330,2
G mm	M10	M12	M12	M16	M12	M16	M16	M20	M20	M24
H mm	18	19,1	24	26	21,5	21	29,8	38,8	39,8	31,6
J mm	78	78	93	93	115	115	140	140	175	175
Wedge stroke K mm	20	20	25	25	28	28	28	28	30	30
M mm	53	53	66	66	81	81	104	104	128	128
N mm	64,9	64,9	80,9	80,9	96,9	96,9	119,9	119,9	149,9	149,9
O max.	11,8	11,8	16,8	34,8	19,5	19,5	18	18	17	17
O min.	-8,2	-8,2	-8,2	9,8	-8,5	-8,5	-10,2	-10,2	-13,2	-13,2
P mm	19	19	19	19	20	20	22	22	25	25
Q mm	M60x1,5	M60x1,5	M75x1,5	M75x1,5	M90x1,5	M90x1,5	M110x2	M110x2	M138x2	M138x2
T mm	90,3	90,3	100,8	118,8	117	117	129	129	137	137
U mm	155	180	195	205	218	235	285	315	365	400
V max. mm	103	103	134	134	155,5	155,5	181	181	214	214
a max.	66	66	90,2	90,2	109,7	109,7	135,2	135,2	158,4	158,4
a min.	37,7	37,7	57,9	57,9	76,7	76,7	85,7	85,7	92,9	92,9
Index adjustment	6(x4,712=28,3)	6(x4,712=28,3)	7(x4,712=32,98)	7(x4,712=32,98)	6(x5,5=33)	6(x5,5=33)	9(x5,5=49,5)	9(x5,5=49,5)	12(x5,5=66)	12(x5,5=66)
b mm	18	18	20	20	20	20	20	20	26	26
e mm	20	20	22	22	26	26	32	32	32	32
f1	M8/14	M8/14	M8/14	M8/14	M10/16	M10/16	M10/16	M10/16	M10/16	M10/16
g1 mm	96	96	108	108	125	125	156	156	190	190
j3	60°	60°	60°	60°	60°	60°	60°	60°	60°	60°
j1	29°	29°	31°	31°	46°	46°	29°	29°	29°	29°
j2	36°	36°	39°	39°	34°	34°	40°	40°	40°	40°
k mm	9	9	19	19	32	32	43	43	39	39
Maximum draw bar pull kN	32	32	47	47	63	63	90	90	120	120
Max. total clamping force approx. kN	64	64	100	100	135	135	180	180	240	240
Max. admissible speed min ⁻¹	6300	6300	6000	6000	4700	4700	4000	4000	3500	3500
Moment of inertia J kgm ²	0,056	0,056	0,14	0,15	0,32	0,33	0,8	0,84	2,3	2,4
Weight without top jaws ca. kg	12,7	13,5	21,2	24	34,7	34,8	57,5	60	104	108
Universal draw tube adapter	optionally available	optionally available	optionally available	optionally available	optionally available	optionally available	optionally available	optionally available	optionally available	optionally available
Adaption to short taper mount DIN ISO 702-1	optionally available	optionally available	optionally available	-	optionally available	optionally available	optionally available	optionally available	optionally available	optionally available

Power chuck DURO-A RC

Jaws DURO-A RC

C 21

Base jaws, 3-jaw-set, hardened, straight tothing, incl. cylinder screws, DIN 912-12.9



Item no.	Chuck Size	Jaw length mm	Jaw width mm
463548	180	65	20
463549	215	85	22
463550	260	104	26
463551	315	115	32
463552	400	125	32

A 36

Reversible top jaws, 3-jaw set, hardened tongue and groove for external and internal clamping - material: 16MnCr5



Item no.	Chuck Size	Jaw length mm	Jaw height mm	Jaw width mm
094012	180	61,5	32,5	20,4
094013	215	70,5	38	24,4
094014	260/315	92	50	34,4
094015	400	107	56	35,7

Additionally or later applied, hardened stepped jaws must be ground out in the chuck.

A28

Unstepped top jaw AB, 3-jaw set standard design, soft - material 16MnCr5



Item no.	Chuck Size	Jaw length mm	Jaw height mm	Jaw width mm
094008	180	85	36,5	20,3
094009	215	105	40	22
094010	260/315	125	50	30
094011	400	145	50	34,3

C 21

One-piece reversible jaws, 3-jaw set, hardened straight tothing - material: 16MnCr5



Item no.	Chuck Size	Jaw length mm	Jaw height mm	Jaw width mm
463555	180	58	44	20
463556	215	75	51	22
463557	260	90	60	26
463558	315	117	66	32
463559	400	137	70	32

Additionally or later applied, hardened jaws must be ground out in the chuck.

C 21

Soft one-piece jaws, 3-jaw set, can be hardened straight tothing, guidance hardened and ground - material: 16MnCr5



Item no.	Chuck Size	Jaw length mm	Jaw height mm	Jaw width mm
463562 ▲	180	65	55	20
463563 ▲	215	84	65	22
463564	260	99	84	26
463565	315	121	90	32
463566 ▲	400	148	100	32

Jaws DURO-A RC

C 21
Reversible claw-type top jaws, standard design tongue and groove, large clamping range, 1 piece, hardened



Item no.	Chuck Size	Jaw length mm	Jaw height mm	Jaw width mm
137060	180	66	37,5	24

C 21
Reversible claw-type top jaws, standard design tongue and groove, small clamping range, 1 piece, hardened



Item no.	Chuck Size	Jaw length mm	Jaw height mm	Jaw width mm
137061	180	66	37,5	20
137064	215	81	43	24
137108	260/315	90	55	34
137114	400	100	62	34

C 21
Reversible claw-type top jaws, standard design tongue and groove, medium clamping range, 1 piece, hardened



Item no.	Chuck Size	Jaw length mm	Jaw height mm	Jaw width mm
137062	180	56	37,5	20
137065	215	66	43	24
137109	260/315	72	55	34
137115	400	86	62	34

C 21
Reversible claw-type top jaws, wide version tongue and groove, small clamping range, 1 piece, hardened



Item no.	Chuck Size	Jaw length mm	Jaw height mm	Jaw width mm
137066	215	79	43	34
137110	260/315	80	55	50
137116	400	93	62	50

C 21
Reversible claw-type top jaws, wide version tongue and groove, large clamping range, 1 piece, hardened



Item no.	Chuck Size	Jaw length mm	Jaw height mm	Jaw width mm
137067	215	81	43	34
137111	260/315	90	55	50
137117	400	106	62	50

C 21
Reversible claw-type top jaws, wide version tongue and groove, medium clamping range, 1 piece, hardened



Item no.	Chuck Size	Jaw length mm	Jaw height mm	Jaw width mm
137068	215	66	43	34
137112	260/315	72	55	50
137118	400	86	62	50

Jaws DURO-A RC

C 21

Draw-down jaws, for interchangeable clamping inserts straight tothing, 1 piece, without clamping inserts



Item no.	Chuck Size	Jaw length mm	Jaw height mm	Jaw width mm
485522 ▲	180	65	43	20
485524 ▲	215	85	47	22
485526	260	104	58	26
485528 ▲	315	115	63	32
485530 ▲	400	125	63	32

C 21

Draw-down jaws, additional clamping range, for interchangeable clamping inserts straight tothing, 1 piece, without clamping inserts



Item no.	Chuck Size	Jaw length mm	Jaw height mm	Jaw width mm
485523 ▲	180	72	43	20
485525 ▲	215	95	47	22
485527 ▲	260	104	58	26
485529 ▲	315	123	63	32
485531 ▲	400	134	63	32

C 15

Interchangeable clamping inserts, 1 piece with claws



Item no.	Chuck Size
141049	180/215
141052	260/315/400

C 15

Interchangeable clamping inserts, 1 piece with serrated tothing



Item no.	Chuck Size
141050	180/215
141053	260/315/400

C 15

Interchangeable clamping inserts, 1 piece with heat treatable surface



Item no.	Chuck Size
141051	180/215
141054	260/315/400

Accessories DURO-A RC

C 15 Mounting screws



Item no.	Size	Contents of delivery	Thread
233058	180/215	piece	M8x20
233030	260/315/400	piece	M12x30

Socket head cap screw to DIN 912, 12.9

C 15 Special grease F80 for lathe chucks for lubrication and conservation of clamping force



Item no.	Design	Contents
308555	Cartridge	0,5 kg
028975	Tin	1 kg

C 15 Changeable workpiece rests (in different lengths)

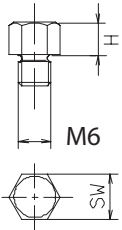

Item no.	H mm	M	Key-width SW
289188	5	M6	9
138950	10	M6	9
725581	15	M6	9

C15 Grease gun DIN1283



Item no.	Connection	Contents of delivery
329093	M10x1	150 mm nozzle tube bent, needlepoint mouthpiece, top mouthpiece, 300 mm high pressure hose with 4 jaw hydraulics cross mouthpiece

C 15 Intermediate adaptor plate with cylindrical centre mount DIN ISO 702-4 for DURO-A RC Mounting from front to DIN ISO 702-1

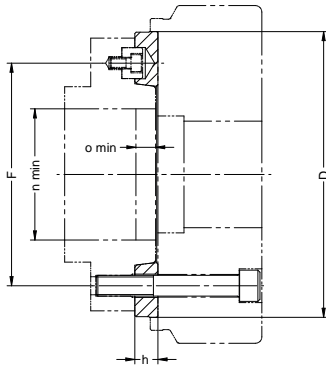

Item No.	Chuck size	D mm	Spindle nose size	h mm	F mm	n min.	o min.
183131	180	140	5	15	104,8	65	8,5
183132	180	170	6	16	133,4	65	8,5
183133	215	170	6	16	133,4	81	8,5
183134	260	170	6	16	133,4	97	9
183135	260	220	8	18	171,4	97	9
183136	315	220	8	28	171,4	120	10
183137	315	300	11	19	235	120	10
183138	400	300	11	19	235	150	14
183139	400	380	15	21	330,2	150	14

All fastening parts are included

Jaw dimensions DURO-A RC

Base jaw GB, with screws

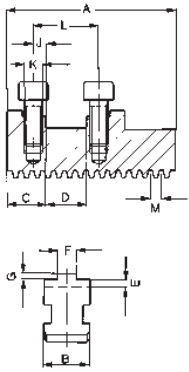

Chuck size	180	215	260	315	400
Type	574-11	574-11	574-11	574-11	574-11
Item no. 3-jaw set	463548	463549	463550	463551	463552
A	65	85	104	115	125
B	20	22	26	32	32
C	19	23	26	26	30
DH7	18	20	20	20	26
E	5	4,5	5,5	6	6
F	8	10	12	12	12
G	2,5	2,5	3	3	3
J	7	10	10	10	14
K	M8	M8	M12	M12	M12
L	32	40	40	40	54
M	4,712	4,712	5,498	5,498	5,498
Weight/set kg	0,7	1,0	1,8	2,7	3,0

Reversible top jaws UB, hardened

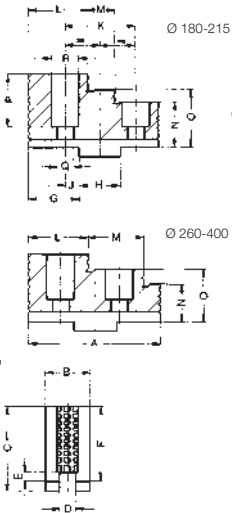

Chuck size	180	215	260	315	400
Type	003-20	003-25	003-30	003-30	003-35
Item no. 3-jaw set	094012	094013	094014	094014	094015
A	61,5	70,35	92	92	107
B	20,4	24,4	34,4	34,4	37,5
C	37	43	55	55	62
D	8	10	12	12	12
E	3	3,5	3,5	3,5	3,5
F	32,5	38	50	50	56
G	22,5	25,5	30	30	35,5
H	18	20	20	20	26
J	7	10	10	10	14
K	32	40	40	40	54
L	26,5	28,5	41	41	40
M	13	14	40,5	40,5	54
N	17,5	18	22	22	26
O	25	28	36	36	41
P	23,5	29	39	39	40
Q	9	9	14	14	14
R	15	15	20	20	20
Weight/set kg	0,6	1,0	2,4	2,4	3,4

Soft top jaws AB, material 16MnCr5

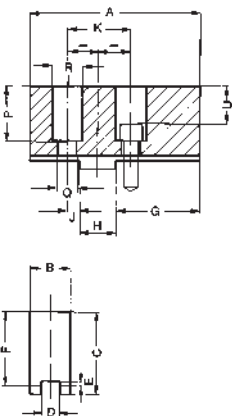

Chuck size	180	215	260	315	400
Type	002-20	002-25	002-30	002-30	002-35
Item no. 3-jaw set	094008	094009	094010	094010	094011
A	85	105	125	125	145
B	20,3	22	30	30	34,3
C	41	45	55	55	56
D	8	10	12	12	12
E	3	3,5	3,5	3,5	3,5
F	36,5	40	50	50	50
G	42	50	70	70	74
H	18	20	20	20	26
J	7	10	10	10	14
K	32	40	40	40	54
P	27,5	31	39	39	34
Q	9	9	14	14	14
R	15	15	20	20	20
U	19,5	23	27	27	22
Weight/set kg	1,3	2,2	4,5	4,5	6,8

Jaw dimensions and chucking capacities DURO-A RC

Reversible one-piece jaws EB

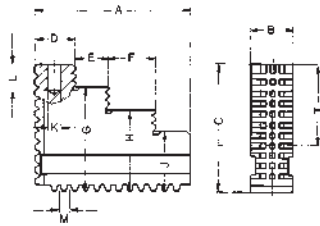

Chuck size	180	215	260	315	400
Type	574-27	574-27	574-27	574-27	574-27
Item no. 3-jaw set	463555	463556	463557	463558	463559
A	58	75	90	117	137
B	20	22	26	32	32
C	44	51	60	66	70
G	37	43	50	56	59
H	30	35	40	46	48
J	23	27	30	36	37
M	4,712	4,712	5,498	5,498	5,498
T	23	26	31	32	36
Weight/set kg	0,6	1,3	2,0	3,4	4,4

Soft one-piece jaws BL, material 16MnCr5

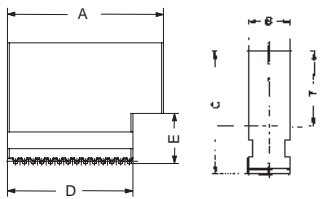

Chuck size	180	215	260	315	400
Type	574-37	574-37	574-37	574-37	574-37
Item no. 3-jaw set	463562	463563	463564	463565	463566
A	65	84	99	121	148
B	20	22	26	32	32
C	55	65	84	90	100
D	56	67,5	77	93	120
E	25	27	36	41	41
T	33	38	53	54	64
Weight/set kg	1,3	2,2	4,3	6,7	9,2

Draw-down jaws NBG, Straight toothing, for inter- changeable clamping inserts (jaw without insert)

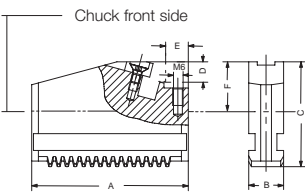

Chuck size	180	215	260	315	400
Jaw design			Type 545-30		
Item no. piece	485522	485524	485526	485528	485530
A	65	85	104	115	125
B	20	22	26	32	32
C	43	47	58	63	63
D	15	15	20	20	20
E	11	12	12	12	12
F	22,5	22,5	29,5	29,5	29,5
Capacities external	38-71	38-102	45-124	42-164	50-190
Capacities internal	125-160	170-223	207-289	234-344	252-397
Max. swing	197	251	306	374	425

Draw-down jaws NBG, for interchangeable clamping inserts (jaw without insert), jaws for further clamping ranges

Chuck size	180	215	260	315	400
Jaw design			Type 549-30		
Item no. piece	485523	485525	485527	485529	485531
A	72	95	104	123	134
E	30	45	50,5	61,5	67
Capacities external	78-110	113-168	123-202	146-262	160-305
Capacities internal	98-122	114-166	131-214	136-245	140-285
Max. swing	197	271	306	390	443

Chucking capacities with reversible top jaws UB

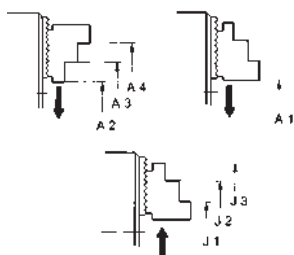

Chuck size		180	215	260	315	400
External chucking	Jaw position					
	A1	11-68	18-84	27-104	25-163	28-240
	A2	33-90	59-125	-	-	-
	A3	77-134	115-181	83-149	111-213	98-243
Internal chucking	A4	103-160	143-209	165-230	193-295	206-351
	J1	65-122	75-141	108-185	143-245	85-230
	J2	91-148	103-169	189-266	225-327	192-337
	J3	135-192	159-225	-	-	-

Jaw dimensions DURO-A RC

Reversible claw-type top jaws KB, standard design

Workpiece stop can be changed and adjusted

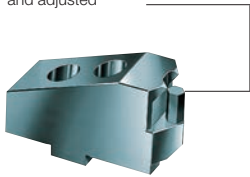

Chuck size	180
Jaw design	Type 544-00 Standard design
Item no. piece	137060
A	66
B	24
C	37,5
D	17
Capacities external	130-159
Capacities internal	53-84

Jaws for further clamping ranges

-8 mm - size 175

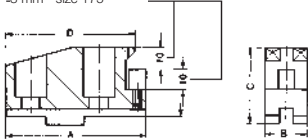

Chuck size	180	215	260	315	400
Jaw design	Type 544-00 Standard design				
Item no. piece	137061	137064	137108	137108	137114
A	66	81	90	90	100
B	20	24	34	34	34
C	37,5	43	55	55	62
D	61	71	78	78	90
Capacities external	25-56	41-103	48-150	48-210	53-237
Capacities internal	136-188	181-255	85-238	136-300	240-435

Accessories: interchangeable workpiece stop (different lengths)

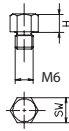

Item no.	289188	138950	725581
M	M6	M6	
H	5	10	15
SW	9		

Chuck size	180	215	260	315	400
Jaw design	Type 544-00 Standard design				
Item no. piece	137062	137065	137109	137109	137115
A	56	66	72	72	86
B	20	24	34	34	34
C	37,5	43	55	55	62
D	29	38,5	38	38	42
Capacities external	68-120	94-168	77-230	127-292	172-333
Capacities internal	93-126	116-200	85-238	136-300	168-329

Reversible claw-type top jaws KB, large design

Workpiece stop can be changed and adjusted

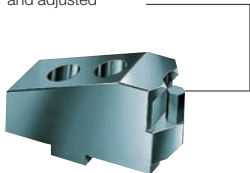

Chuck size	215	260	315	400
Jaw design	Type 544-05 Large design			
Item no. piece	137066	137110	137110	137116
A	79	80	80	93
B	34	50	50	50
C	43	55	55	62
D	29,5	29	29	30
Capacities external	121-226	-	-	-
Capacities internal	74-172	73-203	80-264	130-291

Jaws for further clamping ranges

8 mm - Size175

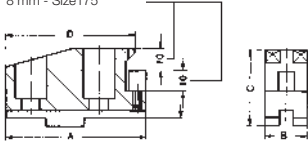

Chuck size	215	260	315	400
Jaw design	Type 544-05 Large design			
Item no. piece	137067	137111	137111	137117
A	81	90	90	106
B	34	50	50	50
C	43	55	55	62
D	71	78	78	90
Capacities external	44-124	53-152	70-214	76-237
Capacities internal	160-274	163-322	222-384	168-425

Chuck size	215	260	315	400
Jaw design	Type 544-05 Large design			
Item no. piece	137068	137112	137112	137118
A	66	72	72	86
B	34	50	50	50
C	43	55	55	62
D	38,5	38	38	42
Capacities external	79-188	77-230	127-292	172-333
Capacities internal	105-210	85-238	136-300	168-329



Notes

DURO-NCSE - individual jaw unlocking



APPLICATION

Premium power chuck with through-hole for flexible use thanks to quick jaw change system for maximum speeds.

TYPE

Power chuck available with cylindrical centre mount or short taper mount. 3-jaw version.

CUSTOMER BENEFITS

- ⊕ Easy handling of the jaw change thanks to individual jaw unlocking
- ⊕ Universal: jaws can be offset, exchanged or turned
- ⊕ For very high speeds - low centrifugal force losses thanks to low jaw weights and wedge bar construction
- ⊕ High clamping precision and clamping force thanks to rigid chuck construction
- ⊕ Large through-hole for hollow or partially hollow clamping

TECHNICAL FEATURES

- Power transmission by means of wedge bar system
- The tothing of the wedge bar always engages completely in the jaw
- Base jaws with straight teeth

Note:

The safety key can only be pulled out once the jaws are locked. This setup in combination with the key switch integrated in the machine also prevents the machine spindle from starting up unintentionally when the jaws are unlocked.

Included in the scope of delivery:

Chuck, chuck and jaw mounting screws, base jaws, safety wrench, mounting wrench

NCSE = NC machine, quick, individual jaw unlocking



Gripping force / speed diagram

The loss of gripping force was determined experimentally on a chuck with matched UB top jaws. It is largely independent of the initial gripping force at zero speed.

Curve:
max. centrifugal
force of top jaw



To obtain the specified gripping forces, the chuck must be in a perfect condition and lubricated with F 80 lubricant recommended by RÖHM. Measuring point near chuck face.

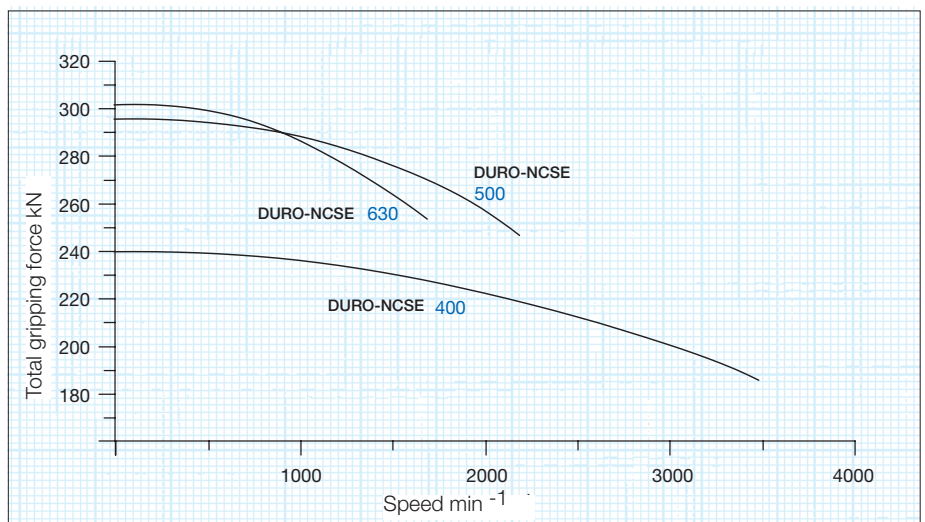
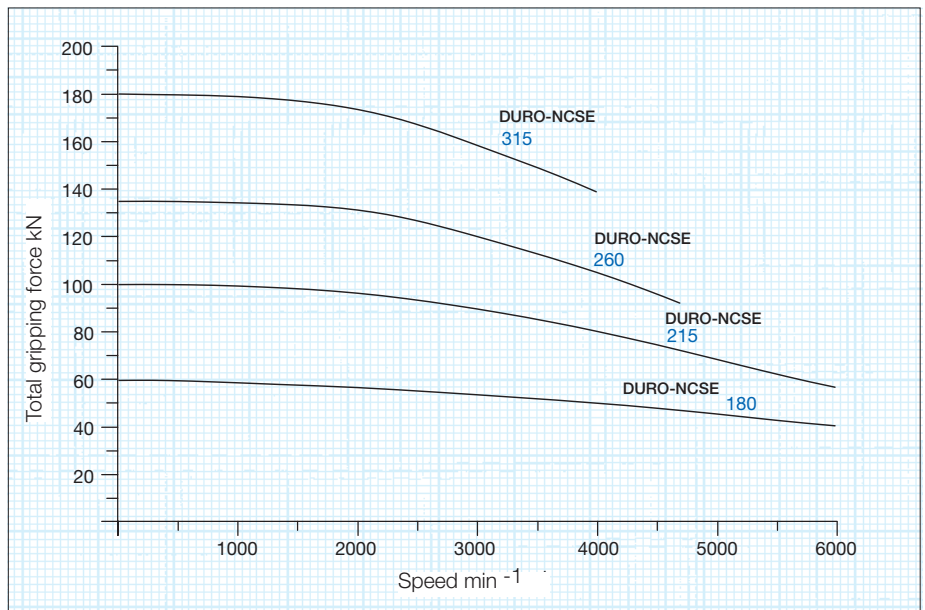

Quick jaw change system with individual jaw unlocking

The individual locking arrangement means that handling is particularly easy with special large jaw pads when the workpiece requires them: push key till stop, then turn in arrow direction.



DURO-NCSE 3-jaw, individual jaw unlocking, straight teeth

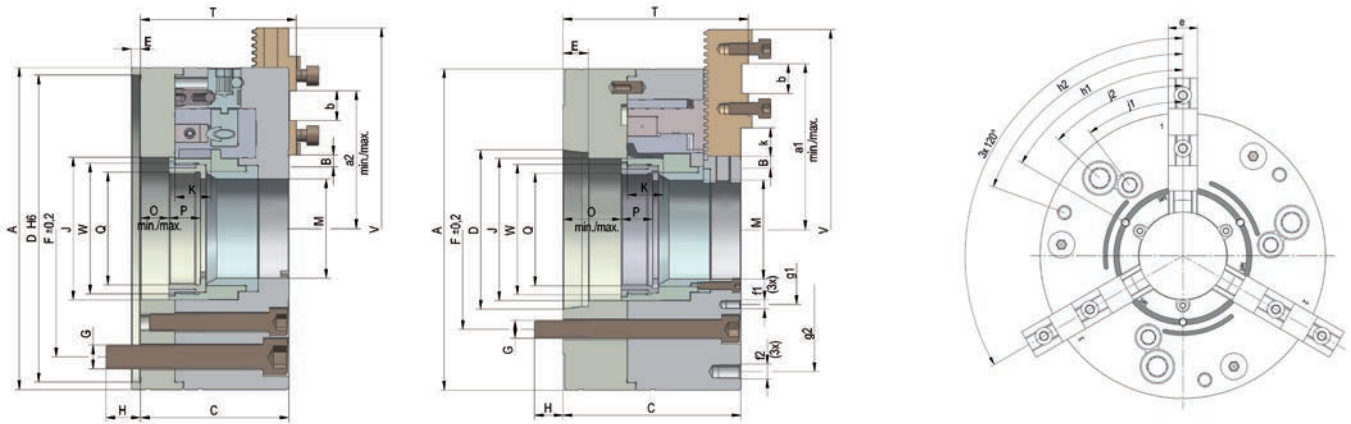

C 15
3-jaw power chucks DURO-NCSE with quick jaw change system, with individual jaw unlocking, with straight teeth
 Cylindrical centre mount DIN 6353 / short taper mount ISO 702-1 (DIN 55026/55021)

Item No.	438355 ▲	438356 ▲	438357 ▲	438358 ▲	438359 ▲	438360 ▲	438361 ▲	438362 ▲	438363 ▲	438364 ▲	438365 ▲
Size	180	180	180	180	215	215	215	260	260	260	260
Toothing	4,712	4,712	4,712	4,712	4,712	4,712	4,712	5,498	5,498	5,498	5,498
A mm	180	180	180	180	215	215	215	260	260	260	260
Jaw travel B mm	6,9	6,9	6,9	6,9	7,8	7,8	7,8	8,8	8,8	8,8	8,8
C mm	91,8	91,8	104,8	105,8	105	119	121	121	121	136	138
D mm	ZA 140	ZA 170	KK 5	KK 6	ZA 170	KK 6	KK 8	ZA 170	ZA 220	KK 6	KK 8
E mm	6	6	16	17	6	17	19	6	6	17	19
F mm	104,8	133,4	104,8	133,4	133,4	133,4	171,4	133,4	171,4	133,4	171,4
G mm	M10	M12	M10	M12	M12	M12	M16	M12	M16	M12	M16
H mm	14	16	16	17	17	18	24	17	26	17	24
J mm	78	78	78	78	95	95	95	115	115	110	110
Wedge stroke K mm	21	21	21	21	24	24	24	28	28	28	28
M mm	53	53	53	53	66	66	66	81	81	81	81
O min.	1	1	14	15	1	15	17	1	1	15	17
O max.	22	22	35	36	25	39	51	29	29	43	45
P mm	17	17	17	17	21	21	21	22	22	22	22
Q mm	M60x1,5	M60x1,5	M60x1,5	M60x1,5	M75x1,5	M75x1,5	M75x1,5	M90x1,5	M90x1,5	M90x1,5	M90x1,5
T mm	98,2	98,2	111,2	112,2	109,9	123,9	125,9	129,5	129,5	144,5	146,5
V max. mm	213	213	213	213	269	269	269	313	313	313	313
W mm	M72x1,5	M72x1,5	M72x1,5	M72x1,5	M87x2	M87x2	M87x2	M105x1,5	M105x1,5	M105x1,5	M105x1,5
a min.	59,1	59,1	59,1	59,1	77,9	77,9	77,9	96,8	96,8	96,8	96,8
a max.	87,4	87,4	87,4	87,4	110,9	110,9	110,9	129,8	129,8	129,8	129,8
a 2 min.	50,1	50,1	50,1	50,1	58,9	58,9	58,9	64,8	64,8	64,8	64,8
a 2 max.	78,4	78,4	78,4	78,4	91,9	91,9	91,9	97,8	97,8	97,8	97,8
Index adjustment	6 (x4,712 =28,3)	6 (x4,712 =28,3)	6 (x4,712 =28,3)	6 (x4,712 =28,3)	7 (x4,712 =32,98)	7 (x4,712 =32,98)	7 (x4,712 =32,98)	6 (x5,5 =33)	6 (x5,5 =33)	6 (x5,5 =33)	6 (x5,5 =33)
b mm	18	18	18	18	20	20	20	20	20	20	20
e mm	20	20	20	20	22	22	22	26	26	26	26
f1	M6/10	M6/10	M6/10	M6/10	M6/10	M6/10	M6/10	M8/15	M8/15	M8/15	M8/15
f2	M8/15	M8/15	M8/15	M8/15	M10/15	M10/15	M10/15	M10/15	M10/15	M10/15	M10/15
g1 mm	83	83	83	83	94	100	100	124	124	124	124
g2 mm	155	155	155	155	190	190	190	220	220	220	220
h1	60°	60°	60°	60°	60°	60°	60°	60°	60°	60°	60°
h2	60°	60°	60°	60°	70°	70°	70°	77°	77°	77°	77°
j1	35°	35°	35°	35°	37°	37°	37°	30°	30°	30°	30°
j2	45°	45°	45°	45°	47°	47°	47°	40°	40°	40°	40°
k mm	9	9	9	9	19	19	19	32	32	32	32
Maximum draw bar pull kN	33	33	33	33	52	53	53	73	73	73	73
Max. total clamping force approx. kN	60	60	60	60	95	100	100	135	135	135	135
Max. admissible speed min ⁻¹	6300	6300	6300	6300	6000	6000	6000	4700	4700	4700	4700
Weight without jaws approx. kg	18	18	18	18	24	26	26	44	44	47	49
Actuating cylinders (recommended)	OVS-105 / SZS-52/130	OVS-105 / SZS-52/130	OVS-105 / SZS-52/130	OVS-105 / SZS-52/130	OVS-130 / SZS-67/130	OVS-130 / SZS-67/130	OVS-130 / SZS-67/130	OVS-150 / SZS-86/200	OVS-150 / SZS-86/200	OVS-150 / SZS-85/200	OVS-150 / SZS-85/200

Power chuck DURO-NCSE

DURO-NCSE 3-jaw, individual jaw unlocking, straight teeth

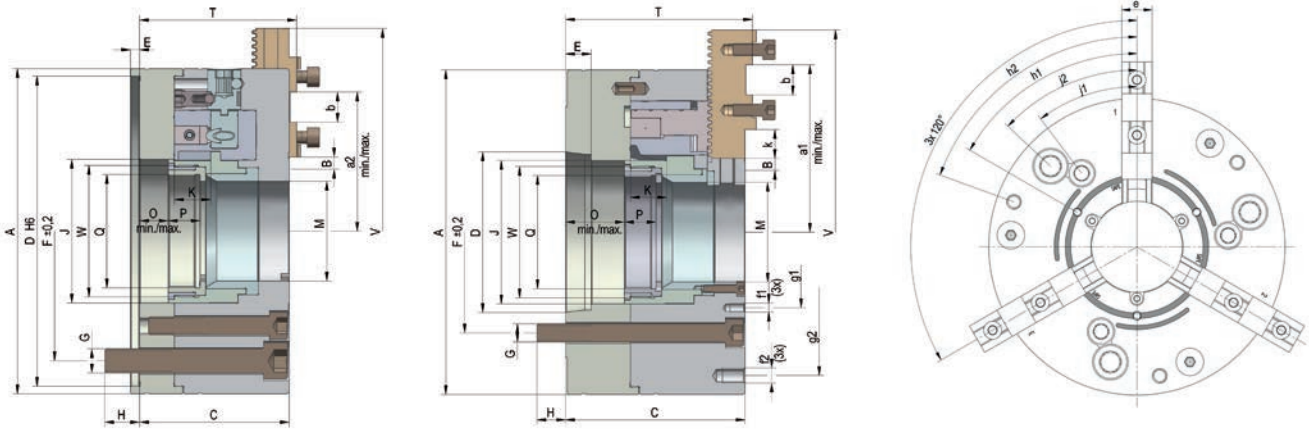

C 15

3-jaw power chucks DURO-NCSE with quick jaw change system, with individual jaw unlocking, with straight teeth
 Cylindrical centre mount DIN 6353 / short taper mount ISO 702-1 (DIN 55026/55021)

Item No.	438366	438367 ▲	438368	438369	438370 ▲	438371 ▲	438372	438373	438374 ▲	438375 ▲	438376 ▲	438377 ▲	438378 ▲
Size	315	315	315	315	400	400	400	400	500	500	500	630	630
Toothing	5,498	5,498	5,498	5,498	5,498	5,498	5,498	5,498	7	7	7	7	7
A mm	315	315	315	315	400	400	400	400	500	500	500	630	630
Jaw travel B mm	9,1	9,1	9,1	9,1	9,8	9,8	9,8	9,8	11,4	11,4	11,4	12,6	12,6
C mm	130	130	146	148	138	138	156	157	162	180	181	179,5	198,5
D mm	ZA 220	ZA 300	KK 8	KK 11	ZA 300	ZA 380	KK 11	KK 15	ZA 380	KK 11	KK 15	ZA 520	KK 15
E mm	6	6	19	21	8	8	21	23	8	21	23	8	23
F mm	171,4	235	171,4	235	235	330,2	235	330,2	330,2	235	330,2	463,6	330,2
G mm	M16	M20	M16	M20	M20	M24	M20	M24	M24	M20	M24	M24	M24
H mm	27	27	26	24	26	36,5	28	37,5	36	30	37	36	37
J mm	140	140	140	140	175,5	175,5	175,5	175,5	207	207	207	235	235
Wedge stroke K mm	28	28	28	28	30	30	30	30	35	35	35	40	40
M mm	104	104	104	104	128	128	128	128	155	155	155	167	167
O min.	1,5	1,5	17,5	19,5	1,5	1,5	19,5	20,5	1,5	19,5	20,5	1,5	20,5
O max.	29,5	29,5	45,5	47,5	31,5	31,5	49,5	50,5	36,5	54,5	55,5	41,5	60,5
P mm	25	25	25	25	29	29	29	29	29	29	29	35	35
Q mm	M110x2	M110x2	M110x2	M110x2	M138x2	M138x2	M138x2	M138x2	M165x2	M165x2	M165x2	M180x2	M180x2
T mm	139	139	155	157	147	147	165	166	172	190	191	189,5	208,5
V max. mm	351	351	351	351	424	424	424	424	524	524	524	643	643
W mm	M130x1,5	M130x1,5	M130x1,5	M130x1,5	M160x2	M160x2	M160x2	M160x2	M188x2	M188x2	M188x2	M215x2	M215x2
a min.	110,4	110,4	110,4	110,4	115,5	115,5	115,5	115,5	155,9	155,9	155,9	194,4	194,4
a max.	159,9	159,9	159,9	159,9	181,5	181,5	181,5	181,5	225,9	225,9	225,9	285,4	285,4
a 2 min.	66,4	66,4	66,4	66,4	76,5	76,5	76,5	76,5	94,9	94,9	94,9	94,4	94,4
a 2 max.	115,9	115,9	115,9	115,9	142,5	142,5	142,5	142,5	164,9	164,9	164,9	185,4	185,4
Index adjustment	9 (x5,5=49,5)	9 (x5,5=49,5)	9 (x5,5=49,5)	9 (x5,5=49,5)	12 (x5,5=66)	12 (x5,5=66)	12 (x5,5=66)	12 (x5,5=66)	10 (x7=70)	10 (x7=70)	10 (x7=70)	13 (x7=91)	13 (x7=91)
b mm	20	20	20	20	26	26	26	26	30	30	30	30	30
e mm	32	32	32	32	32	32	32	32	45	45	45	45	45
f1	M8/15	M8/15	M8/15	M8/15	M8/15	M8/15	M8/15	M8/15	M8/16	M8/16	M8/16	M8/16	M8/16
f2	M12/20	M12/20	M12/20	M12/20	M16/20	M16/20	M16/20	M16/20	M20/37	M20/37	M20/37	M16/30	M16/30
g1 mm	140	140	140	140	170	170	170	170	200	200	200	245	245
g2 mm	268	238	268	268	330,2	330,2	330,2	330,2	420	420	420	520	520
h1	60°	60°	60°	60°	60°	60°	60°	60°	60°	60°	60°	60°	60°
h2	77°	77°	77°	77°	70°	70°	70°	70°	77°	77°	77°	47°	47°
j1	40°	40°	40°	40°	42,5°	42,5°	42,5°	42,5°	30°	30°	30°	45°	45°
j2	45°	45°	45°	45°	45°	45°	45°	45°	45°	45°	45°	60°	60°
k mm	43	43	43	43	39	39	39	39	57	57	57	97	97
Maximum draw bar pull kN	100	100	100	100	133	133	133	133	173	173	173	173	173
Max. total clamping force approx. kN	180	180	180	180	240	240	240	240	305	305	305	312	312
Max. admissible speed min ⁻¹	4000	4000	4000	4000	3500	3500	3500	3500	2200	2200	2200	1700	1700
Moment of inertia J kgm ²	0,96	0,96	0,96	0,96	2,67	2,67	2,67	2,67	16,1	16,1	16,1	22,8	22,8
Weight without jaws approx. kg	66	66	69	70	110	110	118	121	216	233	235	393	430
Actuating cylinders (recommended)	OVS-200 / SZS-110/230	OVS-200 / SZS-110/230	OVS-200 / SZS-110/250	OVS-200 / SZS-110/250	OVS-200 / SZS-127/325	OVS-200 / SZS-127/325	OVS-200 / SZS-127/325	OVS-200 / SZS-127/325	OVS-200 / SZS-127/325	OVS-200	OVS-200	OVS-200	OVS-200

Balancing quality G 6.3 in acc. with DIN 1940

Jaws DURO-NCSE

C 21

Base jaws, 3-jaw-set, hardened straight tothing, incl. cylinder screws, DIN 912-12.9



Item no.	Chuck Size	Jaw length mm	Jaw width mm
463548	180	65	20
463549	215	85	22
463550	260	104	26
463551	315	115	32
463552	400	125	32
463553	500	160	45
463554▲	630	200	45

A 36

Reversible top jaws, 3-jaw set, hardened tongue and groove for external and internal clamping - material: 16MnCr5



Item no.	Chuck Size	Jaw length mm	Jaw height mm	Jaw width mm
094012	180	61,5	32,5	20,4
094013	215	70,5	38	24,4
094014	260/315	92	50	34,4
094015	400	107	56	35,7
094045	500/630	130	72	50,4

Additionally or later applied, hardened stepped jaws must be ground out in the chuck.

A28

Unstepped top jaw AB, 3-jaw set standard design, soft, material 16MnCr5



Item no.	Chuck Size	Jaw length mm	Jaw height mm	Jaw width mm
094008	180	85	36,5	20,3
094009	215	105	40	22
094010	260/315	125	50	30
094011	400	145	50	34,3
094046	500/630	180	73	50,5

C 21

One-piece reversible jaws, 3-jaw set, hardened, straight tothing - material: 16MnCr5



Item no.	Chuck Size	Jaw length mm	Jaw height mm	Jaw width mm
463555	180	58	44	20
463556	215	75	51	22
463557	260	90	60	26
463558	315	117	66	32
463559	400	137	70	32
463560▲	500	176	93	45

Additionally or later applied, hardened jaws must be ground out in the chuck.

C 21

Soft one-piece jaws, 3-jaw set, can be hardened, straight tothing, guidance hardened and ground - material: 16MnCr5



Item no.	Chuck Size	Jaw length mm	Jaw height mm	Jaw width mm
463562▲	180	65	55	20
463563▲	215	84	65	22
463564	260	99	84	26
463565	315	121	90	32
463566▲	400	148	100	32
463567▲	500	175	124	45
463568▲	630	230	134	45

Jaws DURO-NCSE

C 21

Reversible claw-type top jaws, standard design tongue and groove, large clamping range, 1 piece, hardened



Item no.	Chuck Size	Jaw length mm	Jaw height mm	Jaw width mm
137060	180	66	37,5	24
137119	500/630	124	62	50

C 21

Reversible claw-type top jaws, standard design tongue and groove, small clamping range, 1 piece, hardened



Item no.	Chuck Size	Jaw length mm	Jaw height mm	Jaw width mm
137061	180	66	37,5	20
137064	215	81	43	24
137108	260/315	90	55	34
137114	400	100	62	34
137120	500/630	124	62	50

C 21

Reversible claw-type top jaws, standard design tongue and groove, medium clamping range, 1 piece, hardened



Item no.	Chuck Size	Jaw length mm	Jaw height mm	Jaw width mm
137062	180	56	37,5	20
137065	215	66	43	24
137109	260/315	72	55	34
137115	400	86	62	34
137121	500/630	100	62	50

C 21

Reversible claw-type top jaws, wide version tongue and groove, small clamping range, 1 piece, hardened



Item no.	Chuck Size	Jaw length mm	Jaw height mm	Jaw width mm
137066	215	79	43	34
137110	260/315	80	55	50
137116	400	93	62	50

C 21

Reversible claw-type top jaws, wide version tongue and groove, large clamping range, 1 piece, hardened



Item no.	Chuck Size	Jaw length mm	Jaw height mm	Jaw width mm
137067	215	81	43	34
137111	260/315	90	55	50
137117	400	106	62	50

C 21

Reversible claw-type top jaws, wide version tongue and groove, medium clamping range, 1 piece, hardened



Item no.	Chuck Size	Jaw length mm	Jaw height mm	Jaw width mm
137068	215	66	43	34
137112	260/315	72	55	50
137118	400	86	62	50

Jaws DURO-NCSE

C 21

Draw-down jaws, for interchangeable clamping inserts straight toothing, 1 piece, without clamping inserts



Item no.	Chuck Size	Jaw length mm	Jaw height mm	Jaw width mm
485522 ▲	180	65	43	20
485524 ▲	215	85	47	22
485526	260	104	58	26
485528 ▲	315	115	63	32
485530 ▲	400	125	63	32
485532 ▲	500	160	81	45

C 21

Draw-down jaws, additional clamping range, for interchangeable clamping inserts straight toothing, 1 piece, without clamping inserts



Item no.	Chuck Size	Jaw length mm	Jaw height mm	Jaw width mm
485523 ▲	180	72	43	20
485525 ▲	215	95	47	22
485527 ▲	260	104	58	26
485529 ▲	315	123	63	32
485531 ▲	400	134	63	32
485533 ▲	500	160	81	45

C 15

Interchangeable clamping inserts, 1 piece with claws



Item no.	Chuck Size
141049	180/215
141052	260/315/400
141055 ▲	500

C 15

Interchangeable clamping inserts, 1 piece with serrated toothing



Item no.	Chuck Size
141050	180/215
141053	260/315/400
141056 ▲	500

C 15

Interchangeable clamping inserts, 1 piece with heat treatable surface



Item no.	Chuck Size
141051	180/215
141054	260/315/400
141057 ▲	500

Accessories DURO-NCSE

C 15 Mounting screws



Item no.	Size	Contents of delivery	Thread
233058	180/215	piece	M8x20
233030	260/315/400	piece	M12x30
216569	500/630	piece	M16x40

Socket head cap screw to DIN 912, 12.9

C 15 Special grease F80 for lathe chucks for lubrication and conservation of clamping force



Item no.	Design	Contents
308555	Cartridge	0,5 kg
028975	Tin	1 kg

C 15 Changeable workpiece rests (in different lengths)

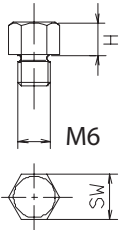

Item no.	H mm	M	Key-width SW
289188	5	M6	9
138950	10	M6	9
725581	15	M6	9

C15 Grease gun DIN1283



Item no.	Conne- ction	Contents of delivery
329093	M10x1	150 mm nozzle tube bent, needlepoint mouthpiece, top mouthpiece, 300 mm high pressure hose with 4 jaw hydraulics cross mouthpiece

Jaw dimensions DURO-NCSE

Base jaw GB, with screws

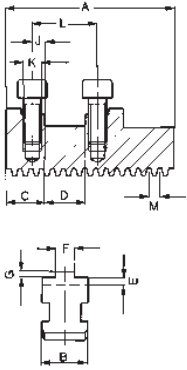

Chuck size	180	215	260	315	400	500	630
Type	574-11	574-11	574-11	574-11	574-11	574-11	574-11
Item no. 3-jaw set	463548	463549	463550	463551	463552	463553	463554
A	65	85	104	115	125	160	200
B	20	22	26	32	32	45	45
C	19	23	26	26	30	35	35
DH7	18	20	20	20	26	30	30
E	5	4,5	5,5	6	6	9	9
F	8	10	12	12	12	16	18
G	2,5	2,5	3	3	3	4	4
J	7	10	10	10	14	15	15
K	M8	M8	M12	M12	M12	M16	M16
L	32	40	40	40	54	60	60
M	4,712	4,712	5,498	5,498	5,498	7	7
Weight/set kg	0,7	1,0	1,8	2,7	3,0	7,1	9

Reversible top jaws UB, hardened

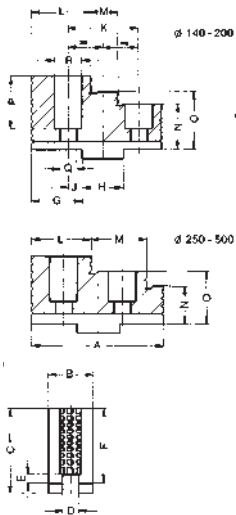

Chuck size	180	215	260	315	400	500	630
Type	003-20	003-25	003-30	003-30	003-35	003-40	003-40
Item no. 3-jaw set	094012	094013	094014	094014	094015	094045	094045
A	61,5	70,35	92	92	107	130	130
B	20,4	24,4	34,4	34,4	37,5	50,4	50,4
C	37	43	55	55	62	79	79
D	8	10	12	12	12	18	18
E	3	3,5	3,5	3,5	3,5	4,5	4,5
F	32,5	38	50	50	56	72	72
G	22,5	25,5	30	30	35,5	41,4	41,4
H	18	20	20	20	26	30	30
J	7	10	10	10	14	15	15
K	32	40	40	40	54	60	60
L	26,5	28,5	41	41	40	51	51
M	13	14	40,5	40,5	54	71	71
N	17,5	18	22	22	26	32	32
O	25	28	36	36	41	52	52
P	23,5	29	39	39	40	57	57
Q	9	9	14	14	14	18	18
R	15	15	20	20	20	26	26
Weight/set kg	0,6	1,0	2,4	2,4	3,4	7,6	7,6

Soft top jaws AB, material 16MnCr5

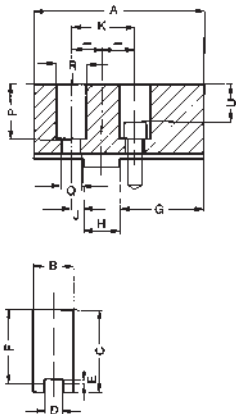

Chuck size	180	215	260	315	400	500	630
Type	002-20	002-25	002-30	002-30	002-35	002-40	002-40
Item no. 3-jaw set	094008	094009	094010	094010	094011	094046	094046
A	85	105	125	125	145	180	180
B	20,3	22	30	30	34,3	50,5	50,5
C	41	45	55	55	56	80	80
D	8	10	12	12	12	18	18
E	3	3,5	3,5	3,5	3,5	4,5	4,5
F	36,5	40	50	50	50	73	73
G	42	50	70	70	74	100	100
H	18	20	20	20	26	30	30
J	7	10	10	10	14	15	15
K	32	40	40	40	54	60	60
P	27,5	31	39	39	34	58	58
Q	9	9	14	14	14	18	18
R	15	15	20	20	20	26	26
U	19,5	23	27	27	22	42	42
Weight/set kg	1,3	2,2	4,5	4,5	6,8	13,2	13,2

Jaw dimensions and chucking capacities DURO-NCSE

Reversible one-piece jaws EB

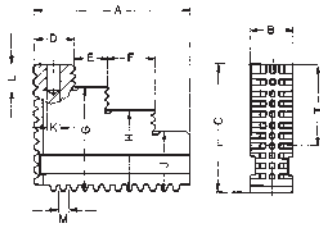

Chuck size	180	215	260	315	400	500/630
Type	574-27	574-27	574-27	574-27	574-27	574-27
Item no. 3-jaw set	463555	463556	463557	463558	463559	463560
A	58	75	90	117	137	176
B	20	22	26	32	32	45
C	44	51	60	66	70	93
G	37	43	50	56	59	73
H	30	35	40	46	48	-
J	23	27	30	36	37	53
M	4,712	4,712	5,498	5,498	5,498	7
T	23	26	31	32	36	46
Weight/set kg	0,6	1,3	2,0	3,4	4,4	11,7

Soft one-piece jaws BL, material 16MnCr5

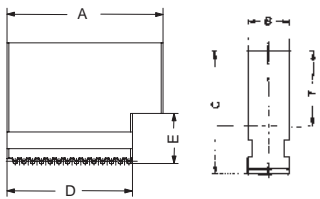

Chuck size	180	215	260	315	400	500	630
Type	574-37	574-37	574-37	574-37	574-37	574-37	574-37
Item no. 3-jaw set	463562	463563	463564	463565	463566	463567	463568
A	65	84	99	121	148	175	230
B	20	22	26	32	32	45	45
C	55	65	84	90	100	124	134
D	56	67,5	77	93	120	154	200
E	25	27	36	41	41	54	54
T	33	38	53	54	64	77	87
Weight/set kg	1,3	2,2	4,3	6,7	9,2	20,5	29,2

Draw-down jaws NBG, Straight toothing, for inter- changeable clamping inserts (jaw without insert)

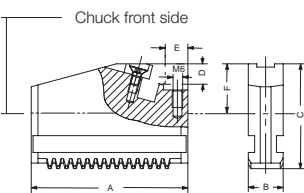

Chuck size	180	215	260	315	400	500
Jaw design	Type 545-30					
Item no. piece	485522	485524	485526	485528	485530	485532
A	65	85	104	115	125	160
B	20	22	26	32	32	45
C	43	47	58	63	63	81
D	15	15	20	20	20	20
E	11	12	12	12	12	12
F	22,5	22,5	29,5	29,5	29,5	34
Capacities external	38-71	38-102	45-124	42-164	50-190	67-217
Capacities internal	125-160	170-223	207-289	234-344	252-397	346-500
Max. swing	197	251	306	374	425	524

Draw-down jaws NBG, for interchangeable clamping inserts (jaw without insert), jaws for further clamping ranges

Chuck size	180	215	260	315	400	500
Jaw design	Type 549-30					
Item no. piece	485523	485525	485527	485529	485531	485533
A	72	95	104	123	134	160
E	30	45	50,5	61,5	67	96
Capacities external	78-110	113-168	123-202	146-262	160-305	230-384
Capacities internal	98-122	114-166	131-214	136-245	140-285	180-332
Max. swing	197	271	306	390	443	524

Chucking capacities with reversible top jaws UB

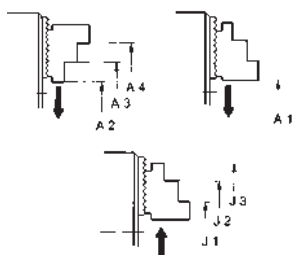

Chuck size	180	215	260	315	400	500	630	
	Jaw position							
External chucking	A1	11-68	18-84	27-104	25-163	28-240	30-304	30-425
	A2	33-90	59-125	-	-	-	-	-
	A3	77-134	115-181	83-149	111-213	98-243	54-290	55-407
	A4	103-160	143-209	165-230	193-295	206-351	195-430	195-549
Internal chucking	J1	65-122	75-141	108-185	143-245	85-230	133-408	133-525
	J2	91-148	103-169	189-266	225-327	192-337	233-548	272-667
	J3	135-192	159-225	-	-	-	-	-

Jaw dimensions DURO-NCSE

Reversible claw-type top jaws KB, standard design

Workpiece stop can be changed and adjusted

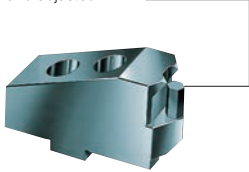

Chuck size	180	500	630
Jaw design	Type 544-00 Standard design		
Item no. piece	137060	137119	137119
A	66	124	124
B	24	50	50
C	37,5	62	62
D	17	39	39
Capacities external	130-159	314-477	390-584
Capacities internal	53-84	101-249	101-290

Jaws for further clamping ranges

.8 mm - size 175

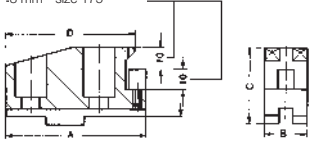

Chuck size	180	215	260	315	400	500	630
Jaw design	Type 544-00 Standard design						
Item no. piece	137061	137064	137108	137108	137114	137120	137120
A	66	81	90	90	100	124	124
B	20	24	34	34	34	50	50
C	37,5	43	55	55	62	62	62
D	61	71	78	78	90	112	112
Capacities external	25-56	41-103	48-150	48-210	53-237	143-294	216-411
Capacities internal	136-188	181-255	85-238	136-300	240-435	268-420	265-460

Accessories: interchangeable workpiece stop (different lengths)

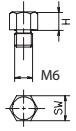

Item no.	289188	138950	725581
M	M6	M6	
H	5	10	15
SW		9	

Chuck size	180	215	260	315	400	500	630
Jaw design	Type 544-00 Standard design						
Item no. piece	137062	137065	137109	137109	137115	137121	137121
A	56	66	72	72	86	100	100
B	20	24	34	34	34	50	50
C	37,5	43	55	55	62	62	62
D	29	38,5	38	38	42	48	48
Capacities external	68-120	94-168	77-230	127-292	172-333	270-422	345-540
Capacities internal	93-126	116-200	85-238	136-300	168-329	142-293	139-333

Reversible claw-type top jaws KB, large design

Workpiece stop can be changed and adjusted

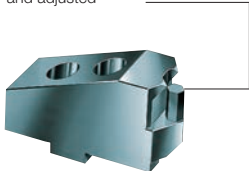

Chuck size	215	260	315	400
Jaw design	Type 544-05 Large design			
Item no. piece	137066	137110	137110	137116
A	79	80	80	93
B	34	50	50	50
C	43	55	55	62
D	29,5	29	29	30
Capacities external	121-226	-	-	-
Capacities internal	74-172	73-203	80-264	130-291

Jaws for further clamping ranges

8 mm - Size175

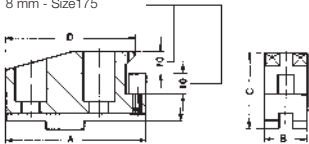

Chuck size	215	260	315	400
Jaw design	Type 544-05 Large design			
Item no. piece	137067	137111	137111	137117
A	81	90	90	106
B	34	50	50	50
C	43	55	55	62
D	71	78	78	90
Capacities external	44-124	53-152	70-214	76-237
Capacities internal	160-274	163-322	222-384	168-425

Chuck size	215	260	315	400
Jaw design	Type 544-05 Large design			
Item no. piece	137068	137112	137112	137118
A	66	72	72	86
B	34	50	50	50
C	43	55	55	62
D	38,5	38	38	42
Capacities external	79-188	77-230	127-292	172-333
Capacities internal	105-210	85-238	136-300	168-329

DURO-NC - central jaw unlocking



APPLICATION

Standard power chuck with through-hole for flexible use thanks to quick jaw change system.

TYPE

Power chuck available with cylindrical centre mount. 3-jaw version.

CUSTOMER BENEFITS

- ④ Universal: Jaws can be offset, exchanged or turned
- ④ For high speeds thanks to lightweight jaws
- ④ High clamping precision and clamping force thanks to proven wedge hook system
- ④ Possible to use jaw units of the DURO manual clamping chuck

TECHNICAL FEATURES

- Central locking of the quick jaw change system
- Power transmission by means of wedge hook system
- Base jaws angle-serrated

Note:

The safety key can only be pulled out once the jaws are locked. This setup in combination with the key switch integrated in the machine also prevents the machine spindle from starting up unintentionally when the jaws are unlocked.

Included in the scope of delivery:

Chuck, chuck and jaw mounting screws, base jaws, safety wrench, mounting wrench

NC = NC machine

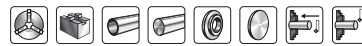

Gripping force / speed diagrams

The loss of gripping force was determined experimentally on a chuck with matched UB top jaws. It is largely independent of the initial gripping force at zero speed.

Upper curve:
min. centrifugal
force of top jaw



Lower curve:
max. centrifugal
force of top jaw



To obtain the specified gripping forces, the chuck must be in a perfect condition and lubricated with F 80 lubricant recommended by RÖHM. Measuring point near chuck face.

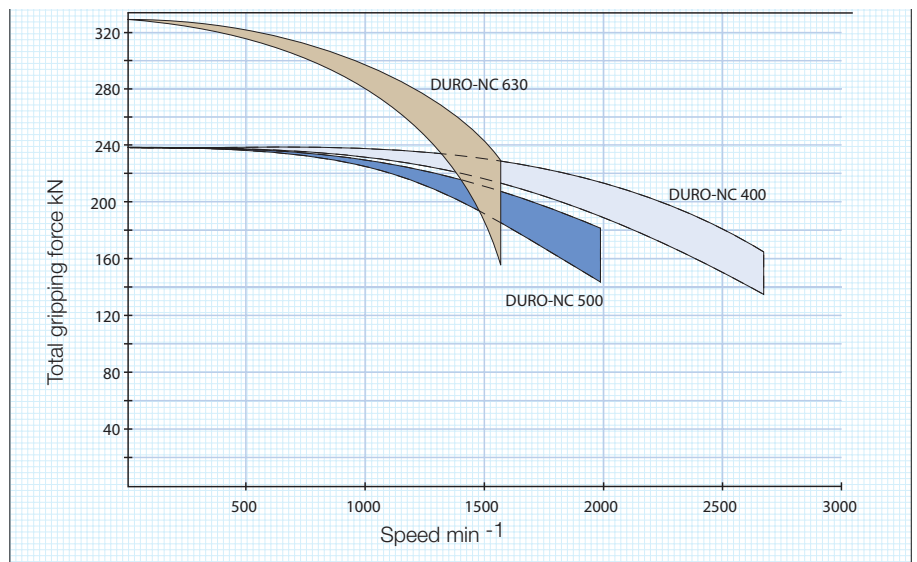
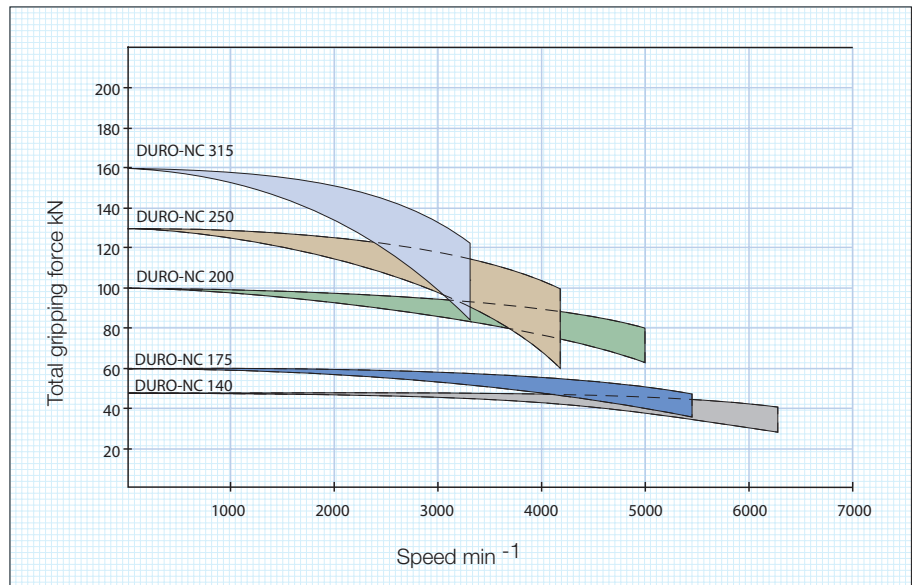

Structure DURO-NC - central jaw unlocking

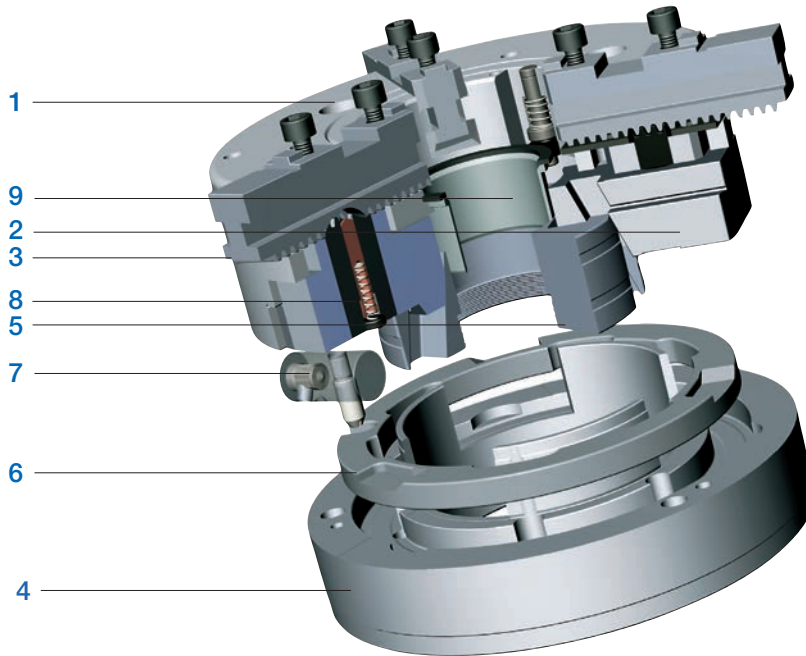

Components:

- 1. Body
- 2. Guide jaw
- 3. Base jaw
- 4. Adaptor plate
- 5. Piston
- 6. Adjusting ring
- 7. Turnable bolt
- 8. Rack
- 9. Protective bush

DURO-NC 3-jaw, central jaw unlocking, angle-serrated

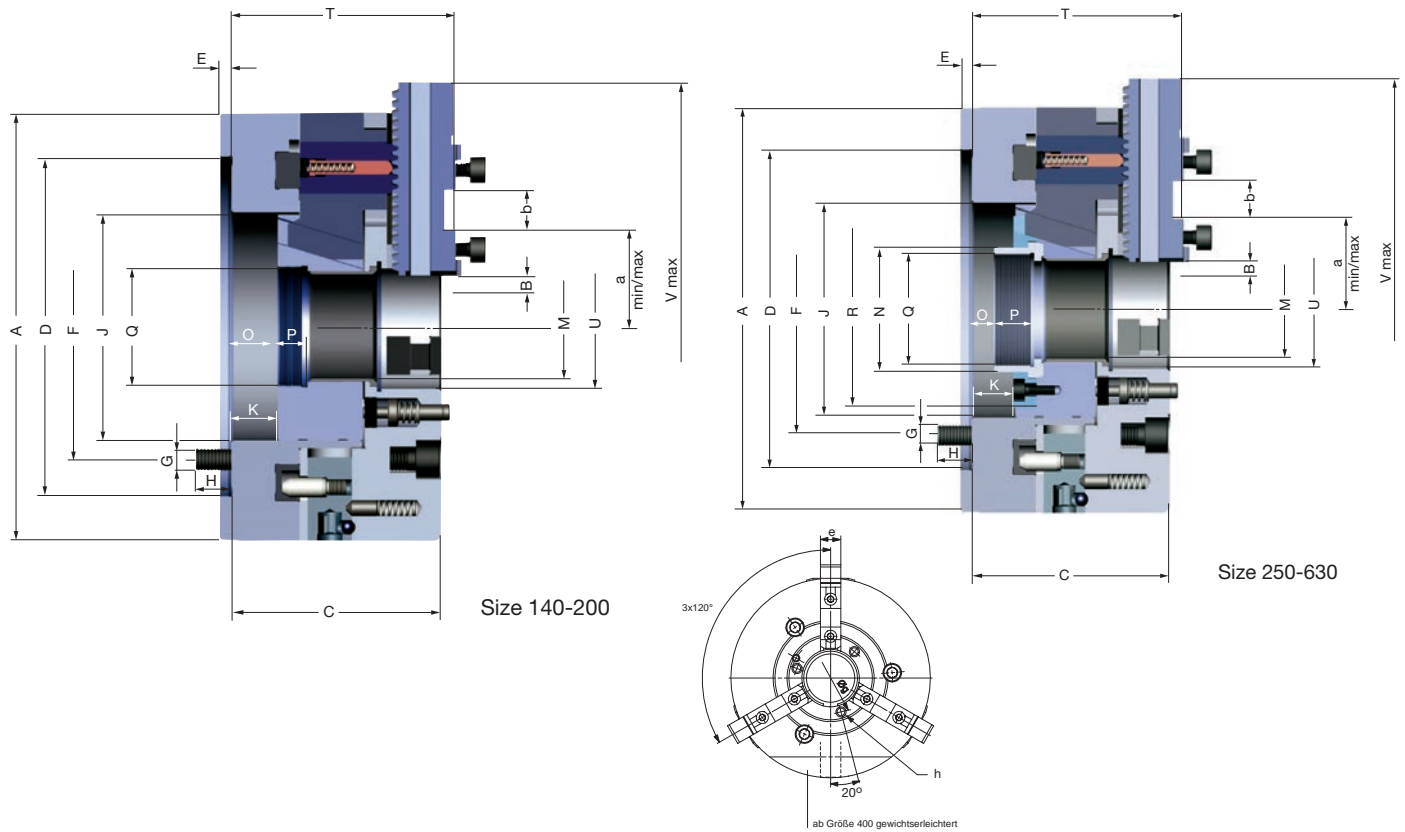

C 15
3-jaws power chuck DURO-NC, with quick jaw change systems, central jaw unlocking, angle-serrated
 Cylindrical centre mount, mounting dimensions to DIN 6353

Item No.	159455 ▲	159456	159457	159458	159459	159460 ▲	159461 ▲	159462 ▲
Size	140	175	200	250	315	400	500	630
A mm	145	175	215	260	320	400	500	630
Jaw travel B mm	4,9	6,7	7	8,25	10,1	11,5	11,5	11,5
C mm	83	99	105	126	152	149	149	169
Mount D ^{h6}	120	140	170	220	300	380	380	380
E mm	6	6	6	6	6	6	6	6
F mm	104,8	104,8	133,4	171,4	235	330,2	330,2	330,2
G mm	3 x M 10	3 x M 10	3 x M 12	3 x M 16	3 x M 20	3 x M 24	3 x M 24	6 x M 24
H mm	18	15	18	21	29	35	35	36
J mm	80	88	114	147	173	210	210	286
Wedge stroke K mm	16	22	23	27	33	46	46	46
M mm	35	43	52	72	91	108	108	140
N mm	-	-	-	-	-	124	124	160
O min.	0,5	0	0	0	0	-61	-61	-41
O max.	16,5	22	23	27	33	-15	-15	5
P mm	9	10	15	15	19	35	35	25
Q mm	M 45 x 1,5	M 50 x 1,5	M 60 x 1,5	M 80 x 1,5	M 100 x 2	M 115 x 2	M 115 x 2	M 148 x 2
R mm	-	-	-	130	160	169	169	219
T mm	89	105	112	134	160,6	158,6	158,6	185
U mm	40	50	62	81	103	120	120	192
V max. mm	181	236	294	351	423	523	570	771
a min.	31,4	33,2	35,5	42,8	52,3	67,1	73,5	86,8
a max.	53,2	62,3	79,5	91,1	115,7	135,5	159	206,1
b mm	18	18	20	20	26	30	30	40
e mm	18	20	22	26	32	45	45	65
Ø g	54	64	76	93	120	140	140	210
h	M 5 x 8	M 6 x 10	M 6 x 10	M 6 x 10	M 6 x 10	M 8 x 12	M 8 x 12	M 8 x 12
Maximum draw bar pull kN	25	30	50	65	80	110	110	150
Max. total clamping force approx. kN	49	60	100	130	160	240	240	330
Max. admissible speed min ⁻¹	6300	5300	5000	4300	3200	2700	2000	1500
Moment of inertia J kgm ²	0,029	0,068	0,162	0,39	1,08	2,5	5	15,4
Weight without jaws approx. kg	11	18	28	46	85	126	185	310
Actuating cylinders (recommended)	OVS-105 / SZS-37/70	OVS-105 / SZS-46/103	OVS-130 / SZS-52/130	OVS-150 / SZS-67/150	OVS-150 / SZS-92/225	OVS-200 / SZS-110/230	OVS-200 / SZS-110/250	OVS-200 / SZS-127/325

Jaws DURO-NC

A28

Base jaw GB, 3-jaw set diagonally toothing, with mounting bolts



Item no.	Chuck Size	Number of jaws	Contents of delivery	Jaw length mm	Jaw width mm
140636	140	3	set	56	18
094004	175	3	set	74	20
094005	200	3	set	90	22
094006	250	3	set	110	26
094007	315	3	set	125	32
094044	400/500	3	set	160	45
140194	630	3	set	230	65

A28

Unstepped top jaw AB, 3-jaw set standard design, soft, material 16MnCr5



Item no.	Chuck Size	Number of jaws	Contents of delivery	Jaw length mm	Jaw height mm	Jaw width mm
094008	140/175	3	set	85	36,5	20,3
094009	200	3	set	105	40	22
094010	250	3	set	125	50	30
094011	315	3	set	145	50	34,3
094046	400/500	3	set	180	73	50,5
140716	630	3	set	260	102	68

A28

Reversible top jaw UB, 3-jaw set hardened



Item no.	Chuck Size	Number of jaws	Contents of delivery	Jaw length mm	Jaw height mm	Jaw width mm
094012	140/175	3	set	61,5	32,5	20,4
094013	200	3	set	70,5	38	24,4
094014	250	3	set	92	50	34,4
094015	315	3	set	107	56	35,7
094045	400/500	3	set	130	72	50,4
140715	630	3	set	185	102	68

Additionally or later applied, hardened jaws must be ground out in the chuck.
For jaws which are applied later, send in the chuck.

A28

Unstepped Jaw BL, 3-jaw set diagonally toothing, unstepped, soft, material 16MnCr5



Item no.	Chuck Size	Number of jaws	Contents of delivery	Jaw length mm	Jaw height mm	Jaw width mm
626158	140	3	set	70,5	41,5	18
241699	175	3	set	84,4	45	20
249678	200	3	set	98,4	60	22
249679	250	3	set	118,7	70	26
249680	315	3	set	136,6	79	32
249681	400/500	3	set	173,6	93	45

A28

One-piece jaw EB, 3-jaw set diagonally toothing, hardened



Item no.	Chuck Size	Number of jaws	Contents of delivery	Jaw length mm	Jaw height mm	Jaw width mm
140764	140	3	set	62	49,5	18
094000	175	3	set	77,7	45	20
094001	200	3	set	94,7	60	22
094002	250	3	set	114	70	26
094003	315	3	set	130	79	32
094043	400/500	3	set	167	93	45

Additionally or later applied, hardened stepped jaws must be ground out in the chuck.
For jaws which are applied later, send in the chuck.

Jaws DURO-NC

C 21
Reversible claw-type top jaws, standard design tongue and groove, large clamping range, 1 piece, hardened



Item no.	Chuck Size	Jaw length mm	Jaw height mm	Jaw width mm
137060	140/175	66	37,5	24
137119	400/500	124	62	50
151288	630	144	78	70

C 21
Reversible claw-type top jaws, standard design tongue and groove, small clamping range, 1 piece, hardened



Item no.	Chuck Size	Jaw length mm	Jaw height mm	Jaw width mm
137061	140/175	66	37,5	20
137064	200	81	43	24
137108	250	90	55	34
137114	315	100	62	34
137120	400/500	124	62	50

C 21
Reversible claw-type top jaws, standard design tongue and groove, medium clamping range, 1 piece, hardened



Item no.	Chuck Size	Jaw length mm	Jaw height mm	Jaw width mm
137062	140/175	56	37,5	20
137065	200	66	43	24
137109	250	72	55	34
137115	315	86	62	34
137121	400/500	100	62	50

C 21
Reversible claw-type top jaws, wide version tongue and groove, small clamping range, 1 piece, hardened



Item no.	Chuck Size	Jaw length mm	Jaw height mm	Jaw width mm
137066	200	79	43	34
137110	250	80	55	50
137116	315	93	62	50

C 21
Reversible claw-type top jaws, wide version tongue and groove, large clamping range, 1 piece, hardened



Item no.	Chuck Size	Jaw length mm	Jaw height mm	Jaw width mm
137067	200	81	43	34
137111	250	90	55	50
137117	315	106	62	50

C 21
Reversible claw-type top jaws, wide version tongue and groove, medium clamping range, 1 piece, hardened



Item no.	Chuck Size	Jaw length mm	Jaw height mm	Jaw width mm
137068	200	66	43	34
137112	250	72	55	50
137118	315	86	62	50

Jaws DURO-NC

C 21

Draw-down jaws, for interchangeable clamping inserts diagonally toothing, 1 piece, without clamping inserts



Item no.	Chuck Size	Jaw length mm	Jaw height mm	Jaw width mm
151030 ▲	140	63	41,5	18
141037	175	84,4	43,5	20
141039	200	98,4	47,5	22
141041	250	118,7	58,5	26
141043	315	136,4	63,9	32
141045	400/500	173,6	73,4	45

C 21

Draw-down jaws, additional clamping range, for interchangeable clamping inserts diagonally toothing, 1 piece, without clamping inserts



Item no.	Chuck Size	Jaw length mm	Jaw height mm	Jaw width mm
151031 ▲	140	63	41,5	18
141038	175	84,4	43,5	20
141040	200	98,4	47,5	22
141042	250	118,7	58,5	26
141044	315	136,4	63,9	32
141046	400	173,6	73,4	45
141048	500	173,6	73,4	45

C 15

Interchangeable clamping inserts, 1 piece with claws



Item no.	Chuck Size
151029 ▲	140
141049	200
141052	250/315
141055 ▲	400/500

C 15

Interchangeable clamping inserts, 1 piece with serrated toothing



Item no.	Chuck Size
151039 ▲	140
141050	175/200
141053	250/315
141056 ▲	400/500

C 15

Interchangeable clamping inserts, 1 piece with heat treatable surface



Item no.	Chuck Size
151040 ▲	140
141051	200
141054	250/315
141057 ▲	400/500

Accessories DURO-NC

C 15 Mounting screws



Item no.	Size	Contents of delivery	Thread
200182	140/175/200	piece	M8x1x22
200183	250	piece	M12x1,5x30
202402	315	piece	M12x1,5x35
227618	400/500	piece	M16x1,5x40
249388	630	piece	M20x50

Socket head cap screw to DIN 912, 12.9

C 15 Special grease F80 for lathe chucks for lubrication and conservation of clamping force



Item no.	Design	Contents
308555	Cartridge	0,5 kg
028975	Tin	1 kg

C 15 Changeable workpiece rests (in different lengths)

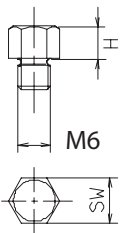

Item no.	H mm	M	Key-width SW
289188	5	M6	9
138950	10	M6	9
725581	15	M6	9

C15 Grease gun DIN1283



Item no.	Connection	Contents of delivery
329093	M10x1	150 mm nozzle tube bent, needlepoint mouthpiece, top mouthpiece, 300 mm high pressure hose with 4 jaw hydraulics cross mouthpiece

C 15

Intermediate adaptor plates with cylindrical centre mount DIN 6353 for 3-jaw chucks

Mounting from front to ISO 702-1 (DIN 55026/55021) and ASA B 5.9 A1/A2 with metric mounting bolts

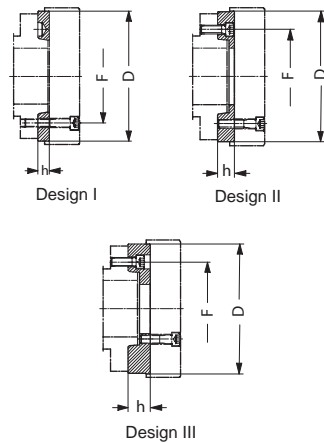

Item no.	Spindle nose size	Size	Design	h mm	F mm	D mm
159878 ▲	5	140	I	15	104,8	120
145153	5	175	I	15	104,8	140
145297	6	175	III	35	133,4	140
182667	6	200	I	16	133,4	170
145131	6	250	II	27	133,4	220
145135	8	200	III	39	171,4	170
145157	8	250	I	18	171,4	220
145139 ▲	8	315	II	38	171,4	300
145143 ▲	11	250	III	48	235	220
145159	11	315	I	19	235	300
145147	11	400	II	40	235	380
145161	15	400/500/630	I	21	330,2	380

All fastening parts are included

Jaw dimensions DURO-NC

Base jaw GB with screws

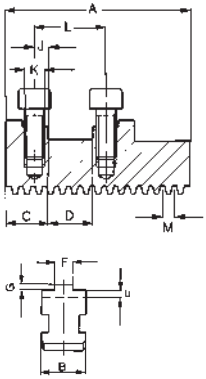

Chuck size	140	175	200	250	315	400/500	630
Type	503-80	002-20	002-25	002-30	002-35	002-40	002-50
Item no. 3-jaw set	140636	094004	094005	094006	094007	094044	140194
A	56	74	90	110	125	160	230
B	18	20	22	26	32	45	65
C	19	19	23	26	30	35	52
D ^{H6}	18	18	20	20	26	30	40
E	5	5	5,5	5,5	6,5	7,5	9
F	8	8	10	12	12	18	24
G	2,5	2,5	3	3	3	4	4
J	7	7	10	10	14	15	21
K	M8x1	M8x1	M8x1	M12x1,5	M12x1,5	M16x1,5	M20
L	32	32	40	40	54	60	82
M	3,63	4,84	4,89	6,03	7,05	8,55	8,53
Weight/set kg	0,43	0,8	1,1	2,1	3,2	7	17

Reversible top jaws UB, hardened

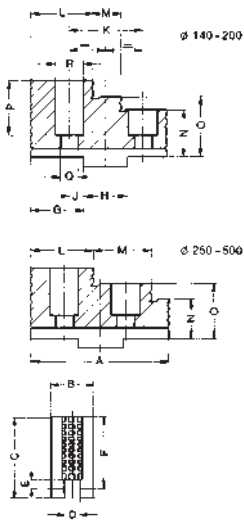

Chuck size	140/175	200	250	315	400/500	630
Type	003-20	003-25	003-30	003-35	003-40	003-50
Item no. 3-jaw set	094012	094013	094014	094015	094045	140715
A	61,5	70,35	92	107	130	185
B	20,4	24,4	34,4	37,5	50,4	68
C	37	43	55	62	79	110
D	8	10	12	12	18	24
E	3	3,5	3,5	3,5	4,5	4,5
F	32,5	38	50	56	72	102
G	22,5	25,5	30	35,5	41,4	59
H	18	20	20	26	30	40
J	7	10	10	14	15	21
K	32	40	40	54	60	82
L	26,5	28,5	41	40	51	80
M	13	14	40,5	54	71	80
N	17,5	18	22	26	32	42
O	25	28	36	41	52	72
P	23,5	29	39	40	57	82
Q	9	9	14	14	18	22
R	15	15	20	20	26	33
Weight/set kg	0,6	1,0	2,4	3,4	7,6	19

Soft top jaws AB, material 16MnCr5

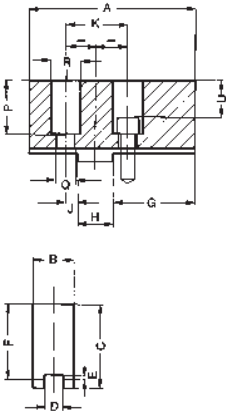

Chuck size	140/175	200	250	315	400/500	630
Type	002-20	002-25	002-30	002-35	002-40	002-50
Item no. 3-jaw set	094008	094009	094010	094011	094046	140716
A	85	105	125	145	180	260
B	20,3	22	30	34,3	50,5	68
C	41	45	55	56	80	110
D	8	10	12	12	18	24
E	3	3,5	3,5	3,5	4,5	4,5
F	36,5	40	50	50	73	102
G	42	50	70	74	100	150
H	18	20	20	26	30	40
J	7	10	10	14	15	21
K	32	40	40	54	60	82
P	27,5	31	39	34	58	83
Q	9	9	14	14	18	22
R	15	15	20	20	26	33
U	19,5	23	27	22	42	63
Weight/set kg	1,3	2,2	4,5	6,8	13,5	40

Jaw dimensions DURO-NC

One-piece reversible jaws EB

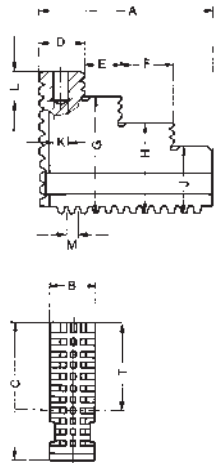

Chuck size	140	175	200	250	315	400/500
Type	503-80	000-20	000-25	000-30	000-35	000-40
Item no. 3-jaw	140764	094000	094001	094002	094003	0940043
A	62	77,7	94,7	114	130	167
B	18	20	22	26	32	45
C	49,5	45	60	70	79	93
D	16,6	20,6	23	41,5	40,2	50,6
E	15,9	18,9	19,5	40,3	54	71
F	18	22	28	-	-	-
G	42	37,5	50	56	64	73
H	34,5	30	40	-	-	-
J	27	22,5	30	42	49	53
K	7	8	10	13	13	20
L	16	16	15	19,5	19,5	30
M	3,63	4,84	4,89	6,03	7,05	8,55
T	29	24	35	41	44,5	54
Weight/set kg	1,2	1,5	1,9	3,4	5,5	11

Soft one-piece jaws BL, material 16MnCr5

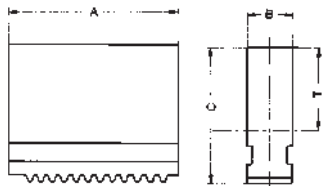

Chuck size	140	175	200	250	315	400/500
Type	503-80	000-20	000-25	000-30	000-35	000-40
Item no. 3-jaw	626158	241699	249678	249679	249680	249681
A	70,5	84,5	98,4	118,7	136,6	173,6
B	18	20	22	26	32	45
C	41,5	45	60	70	79	93
T	21	24	35	41	44,5	54
Weight/set kg	1,3	1,5	2,7	4,4	7,2	15

Draw-down jaws NB for interchangeable clamping inserts (jaw without insert)

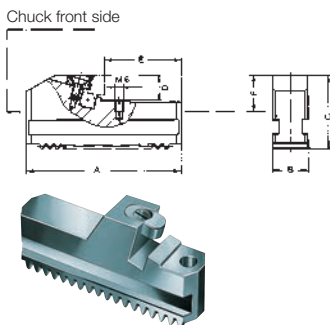

Chuck size	140	175	200	250	315	400	500
Type	545-00	545-00	545-00	545-00	545-00	545-00	545-00
Item no. Piece	151030	141037	141039	141041	141043	141045	141045
A	63	84,4	98,4	118,7	136,4	173,6	173,6
B	18	20	22	26	32	45	45
C	41,5	43,5	47,5	58,5	63,9	73,4	73,4
D	15	15	15	20	20	25	25
E	10,5	11	12	12	12	12	12
F	22,5	22,5	22,5	29,5	29,5	34,3	34,3
Capacities external	40-85	29-80	34-112	38-133	43-170	48-185	48-250
Capacities internal	124-168	162-205	190-263	235-325	275-398	360-490	354-556

Draw-down jaws NB for interchangeable clamping inserts (jaw with insert), jaws for further clamping ranges

Chuck size	140	175	200	250	315	400	500
Type	545-00	545-00	545-00	545-00	545-00	545-00	545-00
Item no. Piece	151031	141038	141040	141042	141044	141046	141048
E	31,5	32	48	58	72	77	110
Capacities external	80-125	70-120	104-185	128-225	160-290	175-316	240-450
Capacities internal	85-126	120-164	120-192	145-236	158-278	230-362	162-360

Accessories: changeable workpiece rests (in different lengths)

	2		
Item no.	289188	138950	725581
M	M6		
H	5	10	15
SW	9		

Jaw dimensions DURO-NC

Reversible claw-type top jaws KB, Standard design

Workpiece stop can be changed and adjusted

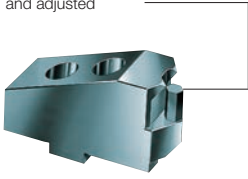

Chuck size	140	175	400	500	630
Jaw design	Type 544-00 Standard design				
Item no. piece	137060		137119		151289
A	66		124		144
B	24		50		70
C	37,5		62		78
D	17		39		61
Capacities external	115-158	115-209	-	-	230-655
Capacities internal	50-84	50-136	100-350	100-410	185-610

Jaws for further clamping ranges

8 mm - Size140/175

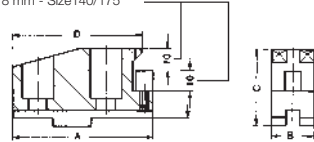

Chuck size	140	175	200	250	315	400	500
Jaw design	Type 544-00 Standard design						
Item no. piece	137061		137064	137108	137114	137120	
A	66		81	90	100		124
B	20		24	34	34		50
C	37,5		43	55	62		62
D	61		71	78	90		112
Capacities external	24-60	24-110	40-130	50-185	50-222	50-270	50-335
Capacities internal	142-182	142-236	166-288	180-350	212-410	280-515	280-580

Accessories: changeable workpiece rests (in different lengths)

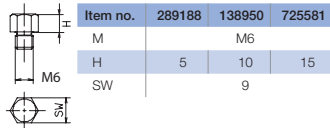

Chuck size	140	175	200	250	315	400	500
Jaw design	Type 544-00 Standard design						
Item no. piece	137062		137065	137109	137115	137121	
A	56		66	72	86		100
B	20		24	34	34		50
C	37,5		43	55	62		62
D	29		38,5	38	42		48
Capacities external	74-118	47-170	76-200	94-260	120-320	165-400	165-465
Capacities internal	80-130	80-176	98-224	104-272	116-315	155-395	155-455

Reversible claw-type top jaws KB, large design

Workpiece stop can be changed and adjusted

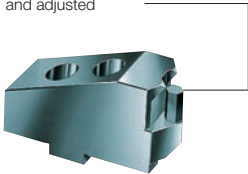

Chuck size	200	250	315
Jaw design	Type 544-05 Large design		
Item no. piece	137066		137110
A	79	80	93
B	34	50	50
C	43	55	62
D	29,5	29	30
Capacities external	121-226	-	-
Capacities internal	74-172	70-235	80-275

Jaws for further clamping ranges

8 mm - Size140/175

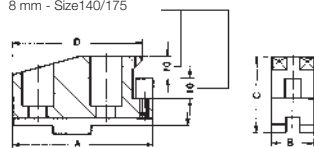

Chuck size	200	250	315
Jaw design	Type 544-05 Large design		
Item no. piece	137067		137111
A	81	90	100
B	34	50	50
C	43	55	62
D	71	78	90
Capacities external	44-124	50-185	50-222
Capacities internal	160-274	180-350	212-410

Chuck size	200	250	315
Jaw design	Type 544-05 Large design		
Item no. piece	137068		137118
A	66	72	86
B	34	50	50
C	43	55	62
D	38,5	38	42
Capacities external	79-188	94-260	120-320
Capacities internal	105-210	104-272	116-315

Chucking capacities DURO-NC

Chucking capacities with reversible top jaws UB

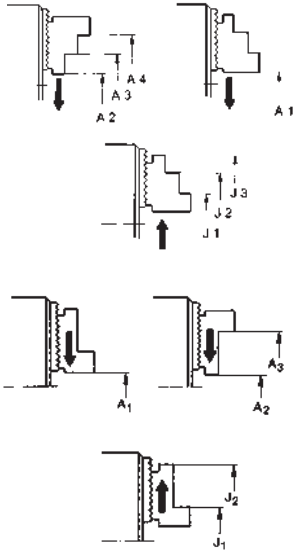

Chuck size		140	160	175	200	250	315	400	500	630
with reversible jaws	Type	003-20	003-20	003-20	003-25	003-30	003-35	003-40	003-40	003-50
	Jaw position									
External chucking	A1	10-58	5-51	5-60	5-65	8-93	30-125	55-156	45-230	42-468
	A2	14-62	45-94	45-103	58-118	-	-	-	-	-
	A3	57-105	89-138	89-147	114-174	82-168	93-210	119-260	122-326	112-487
	A4	89-131	115-164	115-173	142-202	163-249	201-317	260-401	264-470	275-650
Internal chucking	J1	65-112	67-108	67-117	71-126	99-178	120-207	155-260	155-460	195-615
	J2	91-138	93-135	93-144	99-154	178-257	207-313	260-400	265-600	355-780
	J3	133-182	135-177	135-186	154-209	-	-	-	-	-



Notes

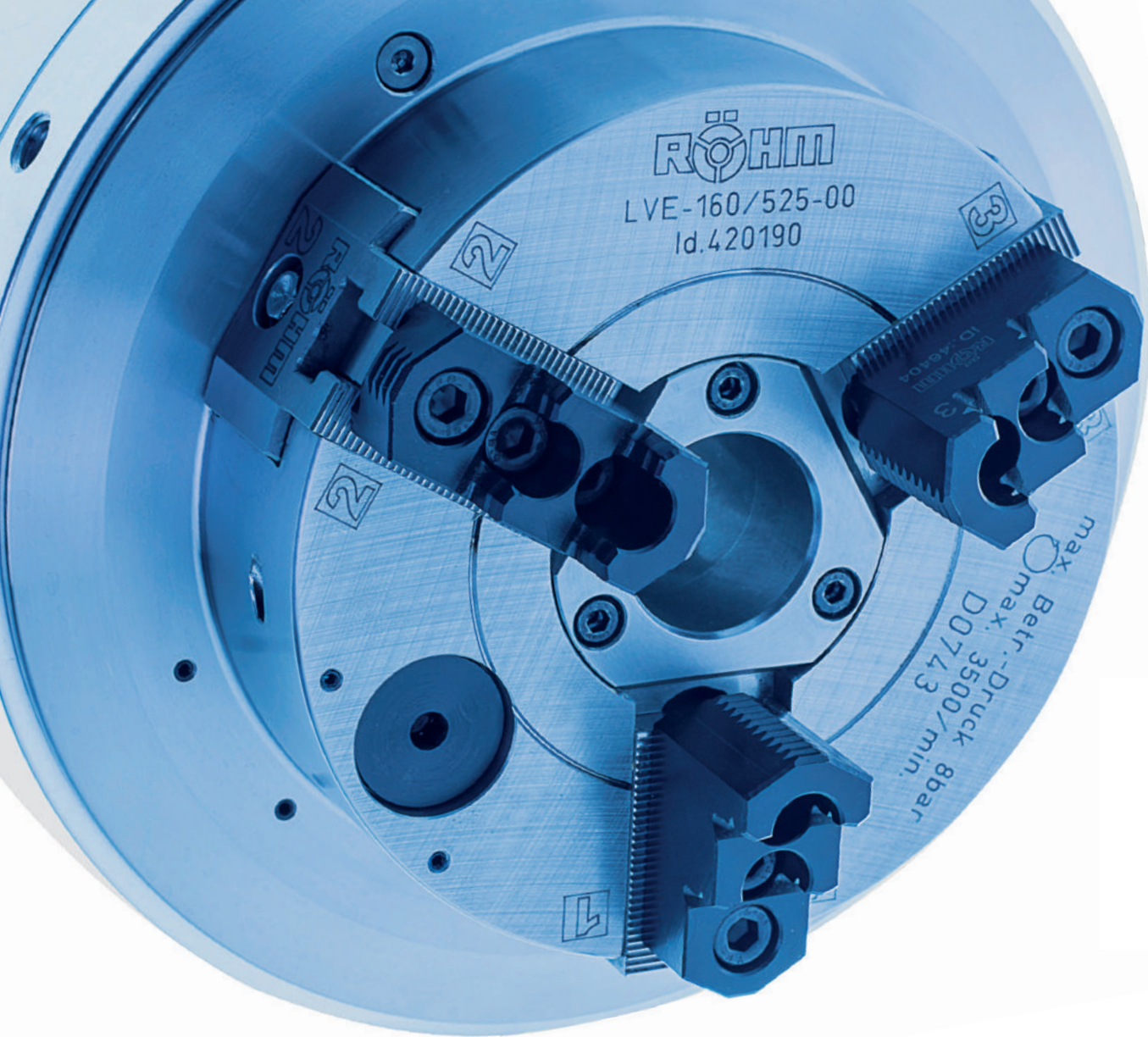

CLAMPING TECHNOLOGY FOR THE ENERGY SECTOR

The crude oil and natural gas industries are still the center of the worldwide energy production today. The extraction and further processing of these two raw materials require top precision and maximum safety. Technically advanced products, such as the air-operated self-contained chucks with through-hole from RÖHM, allow reliable machining of a wide range of workpieces at the top safety standard.

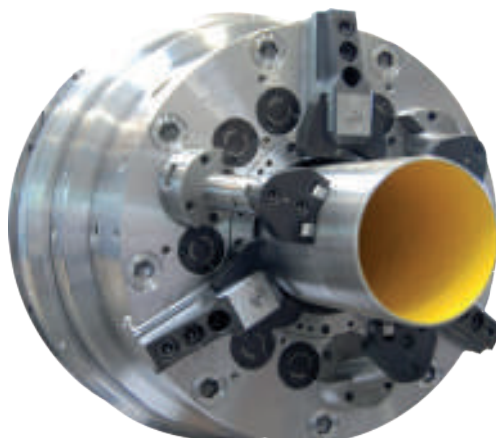

Video LVE

AIR-OPERATED SELF-CONTAINED CHUCKS

Air-operated self-contained chucks LVE are optimally suited for machining the ends of pipes, especially large and long pipes like the ones used for extracting crude oil or natural gas. For this, a chuck is mounted to the front and rear sides of the machine spindle. This combination allows large chip-cutting performance with high workpiece precision.

ADVANTAGES AT A GLANCE

- ⊕ Large through-hole optimal for machining pipes and bars
- ⊕ Cylinders integrated in the power chuck for flexible range of applications
- ⊕ Wedge hook system for high load capacity and clamping precision

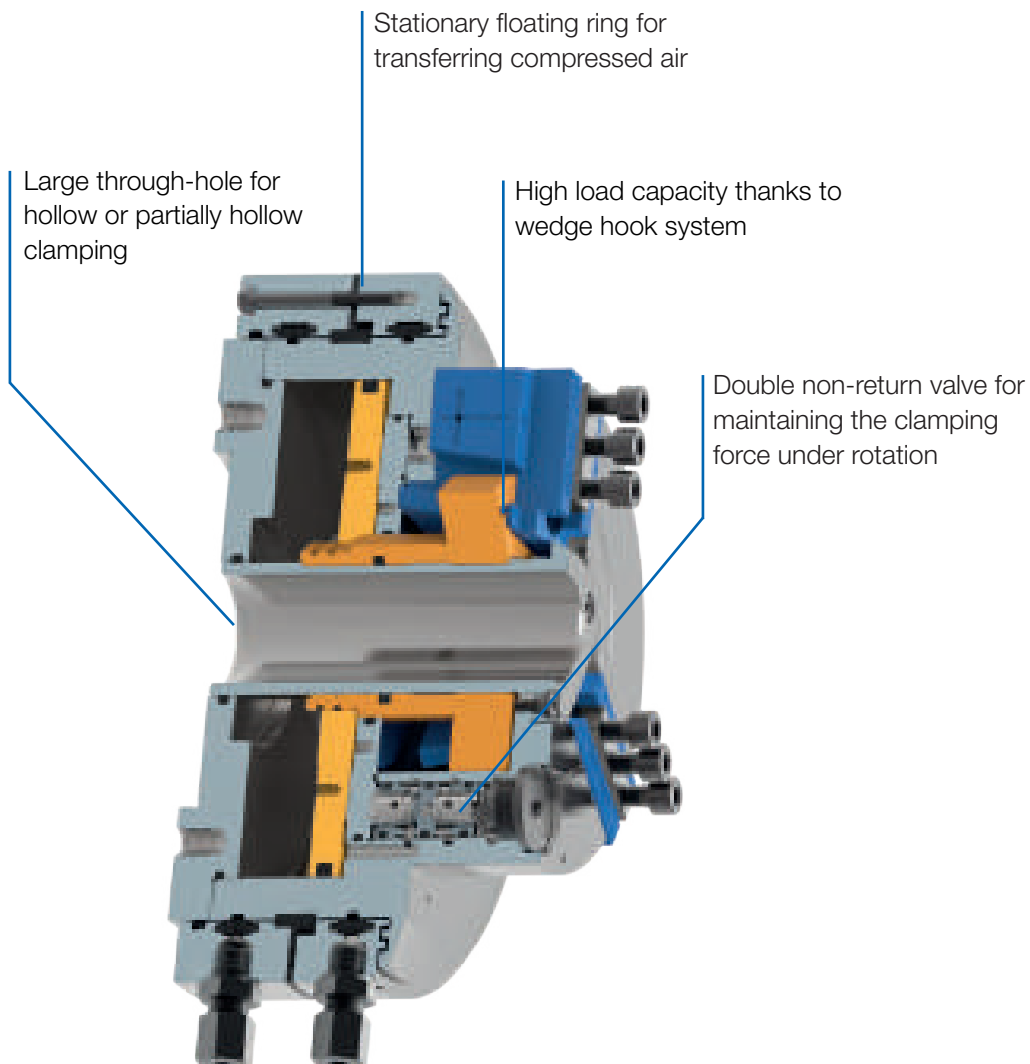

LVE - with integrated pneumatic cylinder



APPLICATION

Optimally suited for flange, bar and tube machining, especially for machines without a clamping cylinder.

TYPE

Power chuck with integrated pneumatic cylinder and cylindrical centre mount. 3-jaw version with serration 90°.

CUSTOMER BENEFITS

- ③ Large through-hole
- ③ Can be easily exchanged with manual clamping chuck
- ③ Compact system dimensions because it is self-contained
- ③ Unobstructed bore through spindle thanks to omission of the draw tube
- ③ High clamping force already at 6 bar

TECHNICAL FEATURES

- Clamping and unclamping only when spindle at standstill
- Wedge hook system with integrated clamping cylinder

Included in scope of delivery:

Chuck, chuck and jaw mounting screws, slot nuts (without top jaws)

LVE = air-operated, self-contained chuck

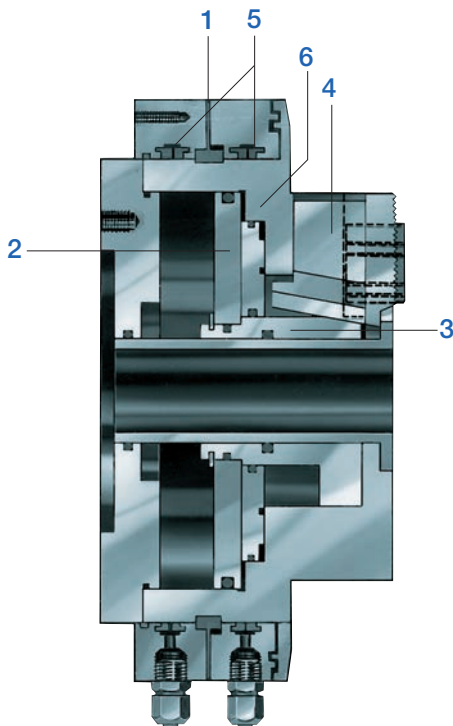
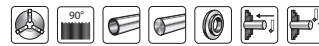

Mode of operation:

The compressed air is conducted through the stationary floating ring **1** via a double non-return valve into one of the two pressure chambers. The force acting on the pressure piston **2** is transferred through the clamping piston to the base jaws **4** via the proven wedge hook system **3**. During the clamping and unclamping operation, profile seals **5** seal off the floating ring **1** from the body **6**. After the clamping operation is finished, the pressure in the chuck body is maintained by the valve, whereby the supply lines are depressurized. The profile seals lift up due to their elasticity and are not damaged by the rotating chuck body.

Components:

1. Floating ring
2. Pressure piston
3. Wedge system
4. Base jaws
5. Special seals
6. Body

LVE up to 10 bar, cylindrical centre Mount, serration 90°

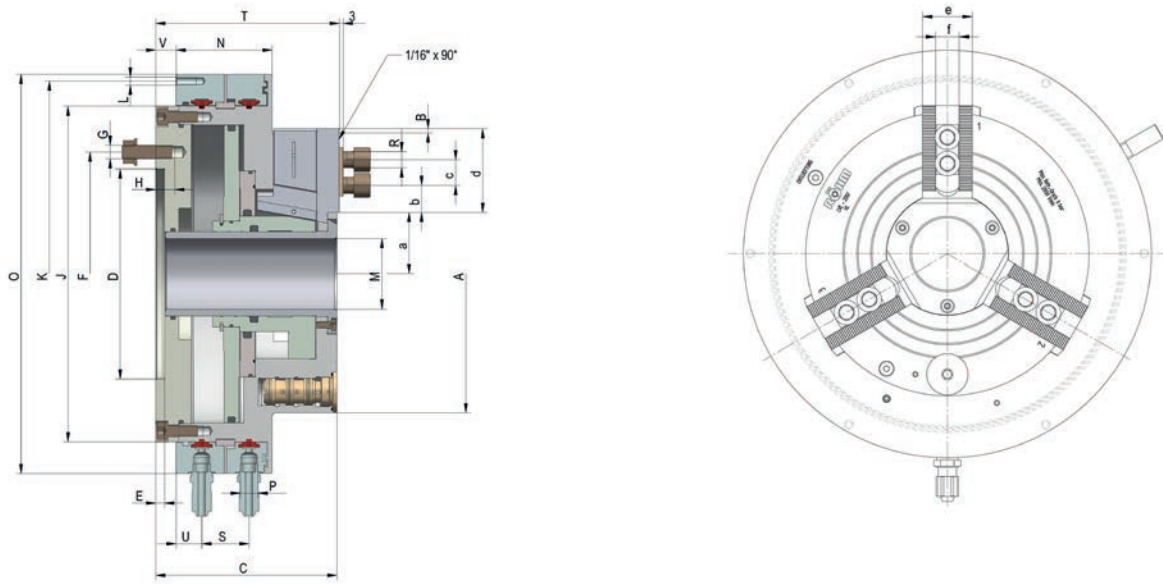

C 15

3-jaw self-contained chucks LVE, with through-hole, max. operating pressure 8 bar, with serration, cylindrical centre mount

Item No.	420189	420190	420191 ▲	420192 ▲	420193 ▲
Size	125	160	200	250	315
A mm	136	168	205	255	320
Jaw travel B mm	3	4,2	4,2	5	5
C mm	101,5	130,5	134	146	156,5
D ⁶ mm	120	125	155	185	225
E mm	6	6,5	6,5	6,5	6,5
F mm	137	150	180	210	250
G	M 8	M 10	M 10	M 10	M 10
H mm	8	13	14	14	14
J mm	164	205	248	315	350
K mm	190	235	285	358	388
L	M 6	M 6	M 6	M 6	M 16
M mm	26	38	52	68	90
N mm	66,5	80,5	71	78,5	79,5
O mm	204	250	295	370	400
P mm	R 1/4"	R 1/4"	R 1/4"	R 1/4"	R 1/4"
R	M 8	M 8	M 12	M 16	M 6
S mm	32	41	35	37	36
T mm	103	131,5	134	147,5	158
U mm	20	20,7	19	19	18
V mm	-	4	15	15,5	25
a min.	24	31,8	41,2	50	61,5
a max.	27	36	45,4	55	66,5
b min.	10	10	13	15	14,5
b max.	21	19,5	35	43	64
c mm	min. 14 / max. 25	2 x 15	19	25	25
d mm	41	49,5	62	78	99
e mm	25	32	36	44	44
f ¹⁷ mm	12	12	17	21	21
Max. operating pressure bar	8	8	8	8	8
Min. operating pressure bar	2	2,5	2,5	2,5	2,5
Total clamping force at 6 bar kN	20	35	60	95	120
Max. admissible speed min ⁻¹	4000	3500	2800	2200	1800
Moment of inertia J kgm ²	0,028	0,125	0,262	0,675	1,35
Air consumption/jaw travel at 6 bar NL	1,5	2,4	3,9	6,6	8,2
Weight without jaws approx. kg	13	25	36	57	85

Higher speeds by fastening the stationary floating ring

LVE chuck with short taper mount ISO 702-3 (DIN 55027, studs and locknuts) on request

LVE chuck with short taper mount ISO 702-2 (DIN55029, studs for Camlock) on request

Jaws LVE

C 21

Reversible top jaws, 3-jaw set, hardened serration 90° - material: 16MnCr5

Item no.	Chuck Size	Jaw length mm	Jaw height mm	Jaw width mm	Serration
046404	125/160	56	37,5	26	1/16"x 90°
118522	200	75	49	36	1/16"x 90°
046414	250/315	103,5	58	50	1/16"x 90°

Additionally or later applied, hardened jaws must be ground out in the chuck.

C 21

Soft top jaws, 3-jaw set, can be hardened serration 90° - material: 16MnCr5

Item no.	Chuck Size	Jaw length mm	Jaw height mm	Jaw width mm	Serration
046403	125/160	55	38	26,5	1/16"x 90°
133153	200	75	53	36,5	1/16"x 90°
133154	250/315	95	54,5	45	1/16"x 90°

Accessories LVE

C 15 Extended T-nuts

With screw

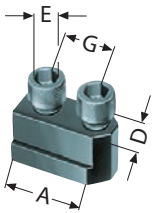

Item no.	Chuck Size	Contents of delivery	D mm	E	G mm
241673 ¹⁾	125	piece	12	M8x20	-
1305178 ▲	160	piece	12	M8x25	2x15
1305179	200	piece	17	M12x30	19
1305180 ▲	250/315	piece	21	M16x35	25

¹⁾ Metric dimensions

Accessories LVE

C 15

Electro-pneumatic safety control block for LVE 125-315

Item no.	Voltage
437747	220 V 50 Hz
437748	24 V Dc

Please order accessories and connection hoses separately

C 15

Manual pulse generator, without cable

Item no.	Contents of delivery
220629 ▲	piece

C 15

Double foot-control switch

Item no.	Contents of delivery
249325 ▲	piece

C 15

Service unit

Item no.	Contents of delivery
367444 ¹⁾ ▲	piece

¹⁾ Consisting of filter, water separator and oiler, R 3/8"

C 15

Connector

Item no.	Chuck Size	Design	Contents of delivery
720233	125-200	snap-on connector CX-R 1/4"-PX-6	piece
720235	125-200	swivel connector LCX-R 1/4"-PX-6	piece
720260	250-315	straight screw-in unions Ø 12/9 R 1/4"	piece
720261	250-315	swivel connector Ø 12/9 R 1/4"	piece

Jaw dimensions und chucking capacities LVE

Reversible top jaws UB,
hardened, serration 90°,
material 16MnCr5

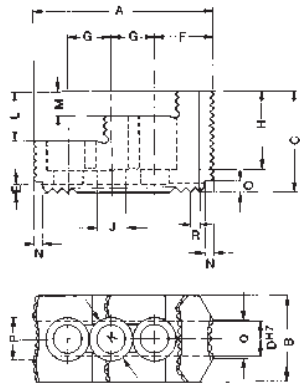

Chuck size	125	160	200	250	315
Type	538-02	538-02	538-04	538-05	538-05
Item no. 3-jaw set	046404	046404	118522	046414	046414
A	56	56	75	103,5	103,5
B	26	26	36	50	50
C	37,5	37,5	49	58	58
DH7	12	12	17	21	21
E	3,5	3,5	5	5	5
F	14	14	21,5	33,5	33,5
G	15	15	19	25	25
H	29	29	37,5	45	45
J	8,4	8,4	13	17	17
K	13,5	13,5	19	25	25
L	20	20	24	28	28
M	10	10	12	14	14
N	4	4	6	6	6
O	4	4	7,5	6,5	6,5
P	5	5	18	24,5	24,5
Q	5	5	7	22,5	22,5
R	1/16" x 90°	1/16" x 90°	1/16" x 90°	1/16" x 90°	1/16" x 90°
Weight/jaw kg	0,170	0,170	0,460	1,130	1,130

Soft top jaws AB,
material 16MnCr5

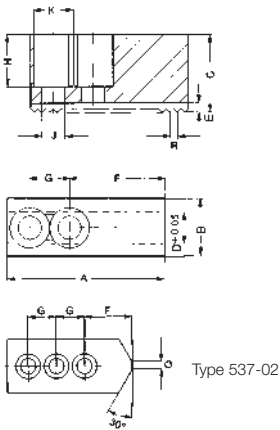

Chuck size	125	160	200	250	250
Type	538-02	538-02	538-04	538-05	538-05
Item no. 3-jaw set	046403	046403	133153	133154	133154
A	55	55	75	95	95
B	26,5	26,5	36,5	45	45
C	38	38	53	54,5	54,5
DH7	12	12	17	21	21
E	3,5	3,5	5	5	5
F	31	31	44	55	55
G	15	15	19	25	25
H	28	28	43	42,5	42,5
J	8,4	8,4	13	17	17
K	13,5	13,5	19	25	25
R	1/16" x 90°	1/16" x 90°	1/16" x 90°	1/16" x 90°	1/16" x 90°
Weight/jaw kg	0,320	0,320	0,880	1,400	1,400

Jaw dimensions und Chucking capacities

Chucking capacities with reversible top jaws UB

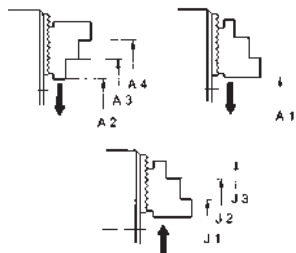

Chuck size		125	160	200	250	315
with reversible jaws	Type	538-02	538-02	538-04	538-05	538-05
	Jaw position					
External chucking	A1	12-63	28-80	30-115	20-128	41-194
	A2	17-69	32-84	44-128	46-154	67-220
	A3	67-119	82-132	101-185	128-238	150-303
	A4	101-153	118-168	152-236	210-318	231-384
Internal chucking	J1	49-99	64-116	80-165	70-188	91-244
	J2	81-131	96-148	130-214	146-255	168-320
	J3	125-175	140-192	182-266	225-334	246-400



Notes

LVE - large through-hole



APPLICATION

Optimal for the end machining of large and long pipes, e.g. for the oil and gas industry (especially as front and rear chuck).

TYPE

Power chuck with integrated pneumatic cylinder and cylindrical centre mount. 3-jaw version with serration 90°.

CUSTOMER BENEFITS

- ⊕ Extra-large through-hole
- ⊕ Can be easily exchanged with manual clamping chuck
- ⊕ Compact system dimensions because it is self-contained
- ⊕ Unobstructed bore through spindle thanks to omission of the draw tube
- ⊕ Flange and bar machining possible without retrofitting

TECHNICAL FEATURES

- Clamping and unclamping only when spindle at standstill
- Wedge hook system with integrated clamping cylinder
- Control valves maintain the clamping pressure during machining
- Short clamping cycle thanks to rapid and clamping stroke (optionally)
- Permanent monitoring of the clamping pressure while machining (optionally)

Note:

Other versions on request: e.g. front-end chucks for compensating clamping, compensating self-contained chucks and chucks that can be converted from self-centering to compensating.

Included in scope of delivery:

Chuck, chuck and jaw mounting screws, slot nuts (without top jaws)

LVE = air-operated, self-contained chuck



Possible application

Two chucks are mounted on the front and rear sides of the machine spindle. Via a selection switch on our electronic control unit DF type 525-90 combined with one pneumatic control unit LSV type 525-91 each, the two chucks can be used together or separately and also with different clamping pressures. This combinations make a high cutting capacity and high turning precision possible for the end machining of long pipes.

Air-operated self-contained chucks, sizes 400-1000

Characteristic for this chuck is a pneumatic piston integrated in the chuck body for generating the clamping force. To clamp or unclamp the workpiece, the compressed air is conducted to the pneumatic piston while the chuck is stationary via the distributor ring and non-return valve. The pneumatic piston is screwed to the clamping piston, with which, in turn, the base jaws are connected via a wedge hook system. An axial movement of the pneumatic piston therefore causes a radial movement of the base jaws.

Distributor ring

The distributor ring has the function of transferring compressed air from the outside into the chuck. This means that the distributor ring is always stationary, while the chuck rotates during workpiece machining. It is therefore mounted to the spindle box, and is therefore secured against rotating along. Special seals seal the gap between the distributor ring and chuck during the clamping operation so that the pressure can be transferred with no problems.

Important: To prevent the sealing ring from being destroyed, the pressure may only be transferred when the chuck is at a standstill.

Control valve

The control valve has the job of securing the compressed air required for clamping in a closed system throughout machining. It automatically secures that piston side which is pressurized, whereby the compressed air of the opposite-lying piston side is unclamped automatically. The valve can be dismounted as a complete unit and is available as replacement unit.

LVE - large through-hole

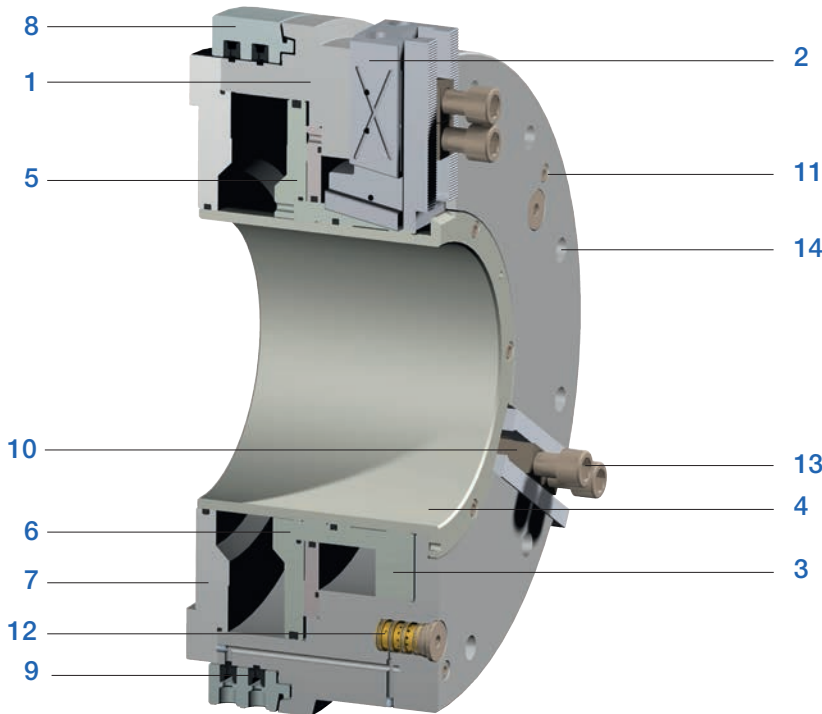

Components LVE

- 1. Body
- 2. Base jaw
- 3. Piston
- 4. Protective bush
- 5. Intermediate washer
- 6. Piston plate
- 7. Flange
- 8. Distributor ring
- 9. Seal
- 10. T-nut
- 11. Air-vent screw
- 12. Control valve
- 13. Jaw fixing screws
- 14. Chuck fixing screws

Control system

The clamping safety mainly depends on the leak-tightness of the closed pneumatic chamber. A pressure drop during machining causes a reduction in the clamping force.

The „**RÖHM control system**“ is used to control the pressure of the closed pneumatic chamber. If the pressure falls below a defined minimum level, a spring-loaded pin attached to the rear side of the chuck moves out to the rear.

At the same height as the pin, a contactless inductive probe is fastened at a certain radial distance. If the extended pin moves through the magnetic field of the probe, an electrical pulse is triggered, which can be used to shut the machine down.

Wedge hook system

The axial piston force is transferred and transmitted into the radial jaw force via the proven wedge hooks. The large force transfer surfaces guarantee a long service life and a sustainably high clamping precision. These features apply both to the chuck with normal jaw stroke as well as to chucks with rapid and gripping jaw movements.

RÖHM control system

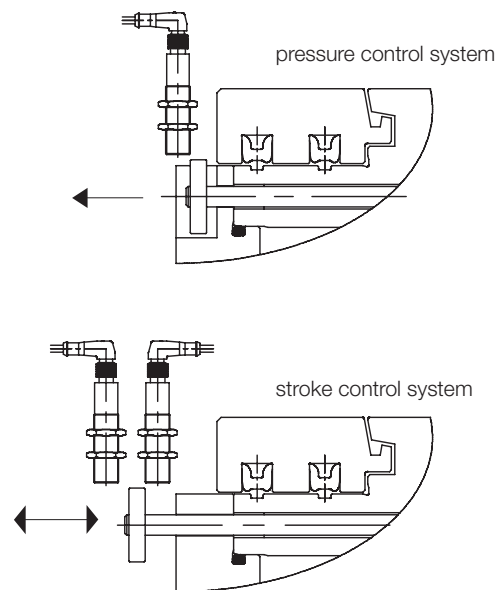

The control unit is designed for LVE chucks with rapid and clamping strokes only for external clamping. For LVE chucks with a normal stroke only pressure control device for the external clamping is provided (on customer demand for internal clamping).

LVE - large through-hole, standard design

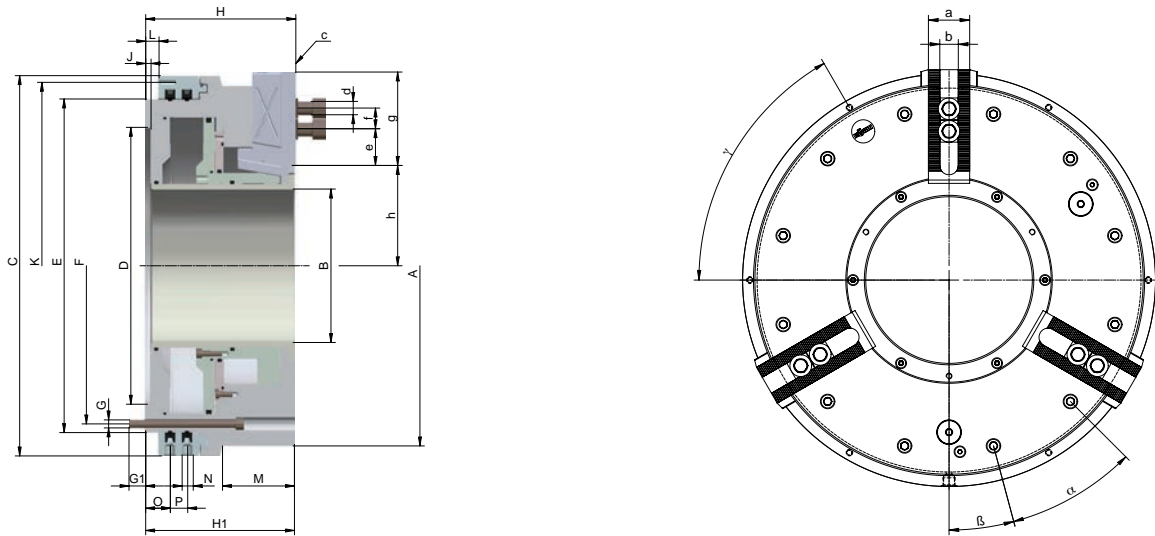

C 15

3-jaw self-contained chucks LVE, with large through-hole, max. operating pressure 8 bar, with serration
Cylindrical centre mount (standard version)

Item No.	169400 ▲	169401	169402 ▲	169403 ▲	169404 ▲	169405 ▲	169406 ▲	169407 ▲	169409 ▲
Size	400	400	500	500	600	600	600	700	800
LVE	LVE 420-140	LVE 480-185	LVE 540-205	LVE 570-230	LVE 600-275	LVE 640-275	LVE 680-325	LVE 730-375	LVE 830-410
Jaw travel mm	7	8,5	8,5	8,5	8,5	10	10	10	12
A mm	425	480	540	570	605	640	685	735	835
B mm	140	185	205	230	275	275	325	375	410
C mm	470	530	570	570	605	685	685	735	850
D ^ø mm	310	365	415	415	450	510	510	560	700
E mm	400	460	500	500	535	610	610	660	775
F mm	374	434	474	474	508	580	580	630	745
G	M12	M12	M12	M12	M12	M16	M16	M16	M16
G1 mm	25	25	25	25	25	30	30	30	30
H mm	196	225	225	225	225	263	263	263	305
H1 mm	194	223	223	223	223	261	261	261	303
J mm	8	8	8	8	8	8	8	8	8
K mm (6xM8)	448	510	550	550	585	666	666	716	830
L mm	20	20	20	20	20	20	20	20	25
M mm	70	90	100	-	-	110	-	-	155
N	G 3/8	G 3/8	G 3/8	G 3/8	G 3/8	G 1/2	G 1/2	G 1/2	G 1/2
O mm	37	37	37	37	37	39,5	39,5	39,5	44,5
P mm	26	26	26	26	26	33	33	33	33
a mm	57	57	57	57	57	75	75	75	75
bH7 mm	25,5	25,5	25,5	25,5	25,5	30	30	30	30
c inch	3/32"x90°	3/32"x90°	3/32"x90°	3/32"x90°	3/32"x90°	3/32"x90°	3/32"x90°	3/32"x90°	3/32"x90°
d	M20x50	M20x50	M20x50	M20x50	M20x50	M24x60	M24x60	M24x60	M24x60
e mm	20	20	20	20	20	28	28	28	28
f min.	32	32	32	32	32	42	42	42	42
f max.	85	85	105	105	100	100	100	100	125
g mm	120	120	140	140	135	145	145	145	173
h min.	94	118,5	129	141,5	164	175	195	220	242,5
h max.	101	127	137,5	150	172,5	185	205	230	254,5
α degree	30°	30°	30°	30°	30°	30°	30°	30°	30°
β degree	15°	15°	15°	15°	15°	15°	15°	15°	15°
γ degree	60°	60°	60°	60°	60°	60°	60°	60°	60°
Min. operating pressure bar	2	2	2	2	2	2	2	2	3
Max. operating pressure bar	8	8	8	8	8	8	8	8	8
Total clamping force at 6 bar kN	140	155	210	190	200	240	180	205	325
Cylinder surface area cm ²	710	899	1045	940	1010	1414	1181	1341	2121
Air consumption (total stroke) l	20	31	36	32	35	58	49	55	104
Max. admissible speed min ⁻¹	1700	1500	1300	1300	1200	1000	900	800	750
Moment of inertia kgm ²	3.50	7.00	10.50	12.50	15.50	24.75	29.50	38.50	76.25
Weight kg	150	215	263	272	289	423	426	470	723

LVE - large through-hole, with pressure control device

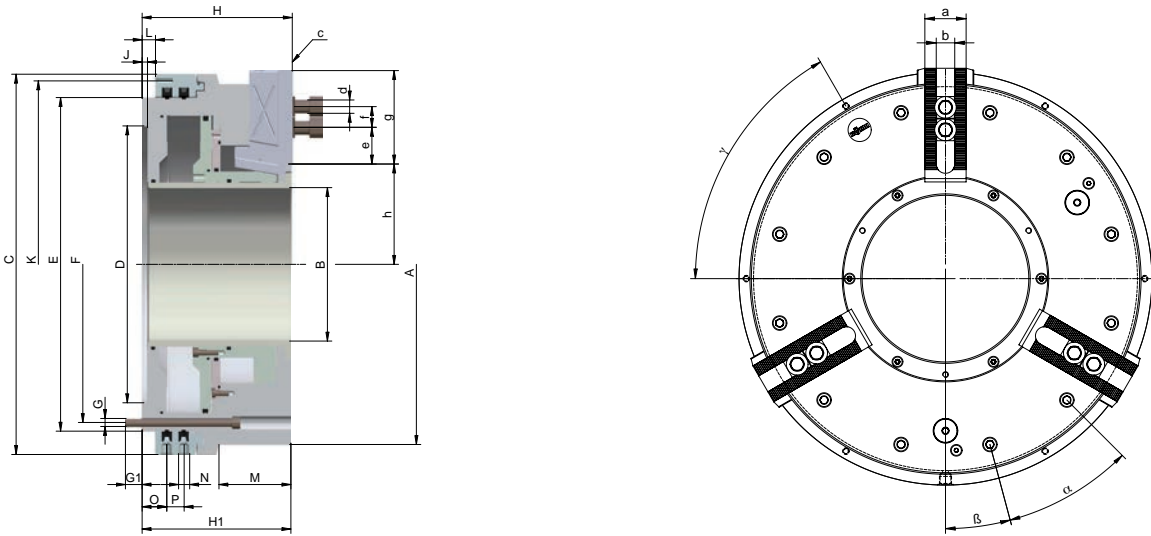

C 15

3-jaw self-contained chucks LVE, with large through-hole, max. operating pressure 8 bar, with serration
Cylindrical centre mount with pressure control device for external clamping

Item No.	169411 ▲	169412 ▲	169413 ▲	169414 ▲	169415 ▲	169416 ▲	169417 ▲	169418 ▲	169420 ▲
Size	400	400	500	500	600	600	600	700	800
LVE	LVE 420-140	LVE 480-185	LVE 540-205	LVE 570-230	LVE 600-275	LVE 640-275	LVE 680-325	LVE 730-375	LVE 830-410
Jaw travel mm	7	8,5	8,5	8,5	8,5	10	10	10	12
A mm	425	480	540	570	605	640	685	735	835
B mm	140	185	205	230	275	275	325	375	410
C mm	470	530	570	570	605	685	685	735	850
D ⁶ mm	310	365	415	415	450	510	510	560	700
E mm	400	460	500	500	535	610	610	660	775
F mm	374	434	474	474	508	580	580	630	745
G	M12	M12	M12	M12	M12	M16	M16	M16	M16
G1 mm	25	25	25	25	25	30	30	30	30
H mm	196	225	225	225	225	263	263	263	305
H1 mm	194	223	223	223	223	261	261	261	303
J mm	8	8	8	8	8	8	8	8	8
K mm (6xM8)	448	510	550	550	585	666	666	716	830
L mm	20	20	20	20	20	20	20	20	25
M mm	70	90	100	-	-	110	-	-	155
N	G 3/8	G 3/8	G 3/8	G 3/8	G 3/8	G 1/2	G 1/2	G 1/2	G 1/2
O mm	37	37	37	37	37	39,5	39,5	39,5	44,5
P mm	26	26	26	26	26	33	33	33	33
a mm	57	57	57	57	57	75	75	75	75
bH7 mm	25,5	25,5	25,5	25,5	25,5	30	30	30	30
c inch	3/32"x90°	3/32"x90°	3/32"x90°	3/32"x90°	3/32"x90°	3/32"x90°	3/32"x90°	3/32"x90°	3/32"x90°
d	M20x50	M20x50	M20x50	M20x50	M20x50	M24x60	M24x60	M24x60	M24x60
e mm	20	20	20	20	20	28	28	28	28
f min.	32	32	32	32	32	42	42	42	42
f max.	85	85	105	105	100	100	100	100	125
g mm	120	120	140	140	135	145	145	145	173
h min.	94	118,5	129	141,5	164	175	195	220	242,5
h max.	101	127	137,5	150	172,5	185	205	230	254,5
α degree	30°	30°	30°	30°	30°	30°	30°	30°	30°
β degree	15°	15°	15°	15°	15°	15°	15°	15°	15°
γ degree	60°	60°	60°	60°	60°	60°	60°	60°	60°
Min. operating pressure bar	2	2	2	2	2	2	2	2	3
Max. operating pressure bar	8	8	8	8	8	8	8	8	8
Total clamping force at 6 bar kN	140	155	210	190	200	240	180	205	325
Cylinder surface area cm ²	710	899	1045	939	1010	1414	1181	1341	2121
Air consumption (total stroke) l	20	31	36	32	35	58	49	55	104
Max. admissible speed min ⁻¹	1700	1500	1300	1300	1200	1000	900	800	750
Moment of inertia kgm ²	3.50	7.00	10.50	12.50	15.5	24.75	29.50	38.50	76.25
Weight kg	150	215	263	272	289	423	426	470	723

LVE - large through-hole, standard design, with rapid and clamping jaw movement

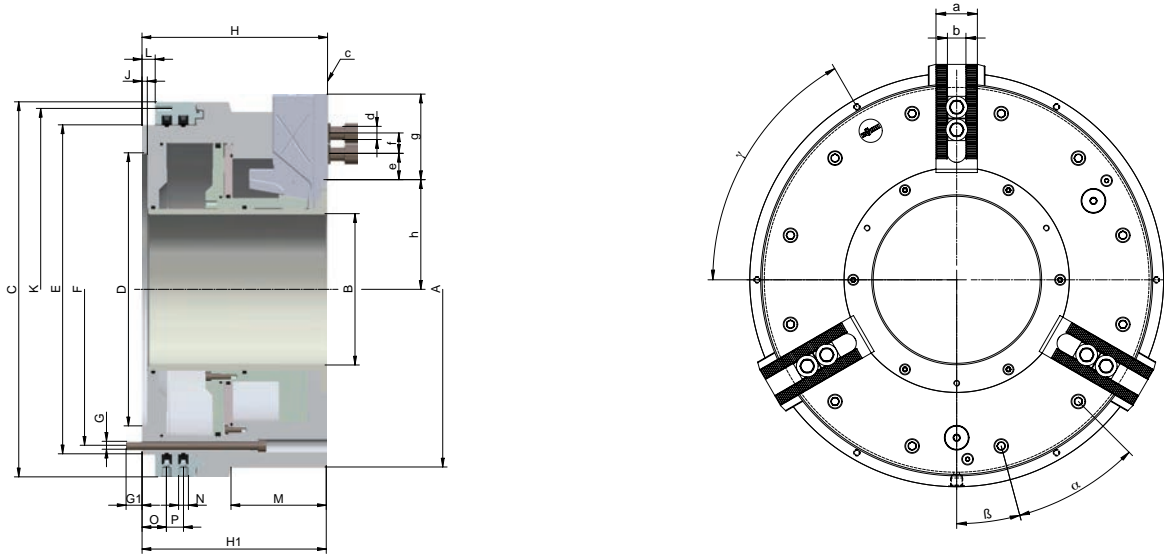

C 15
3-jaw self-contained chucks LVE, with rapid and clamping jaw movements, with large through-hole, external chucking, max. operating pressure 8 bar, with serration
 Cylindrical centre mount (standard version)

Item No.	169422 ▲	169423	169424 ▲	169425 ▲	169426 ▲	169427 ▲	169428 ▲	169429 ▲	169431 ▲
Size	400	400	500	500	600	600	600	700	800
LVE	LVE 470-140 ES	LVE 490-185 ES	LVE 570-205 ES	LVE 570-230 ES	LVE 600-275 ES	LVE 640-275 ES	LVE 680-325 ES	LVE 730-375 ES	LVE 850-410 ES
Jaw travel mm	19	25,4	25,4	25,4	25,4	25,4	25,4	25,4	25,4
Rapid movement mm	12	16,9	16,9	16,9	16,9	16,9	16,9	16,9	14,9
clamping movement mm	7	8,5	8,5	8,5	8,5	8,5	8,5	8,5	10,5
A mm	470	490	570	570	605	645	685	735	850
B mm	140	185	205	230	275	275	325	375	410
C mm	470	530	570	570	605	685	685	735	850
D ^ø mm	310	365	415	415	450	510	510	560	700
E mm	400	460	500	500	535	610	610	660	775
F mm	374	434	474	474	508	580	580	630	745
G	M12	M12	M12	M12	M12	M16	M16	M16	M16
G1 mm	25	25	25	25	25	30	30	30	30
H mm	240	282	282	282	282	308	308	308	322
H1 mm	238	280	280	280	280	306	306	306	320
J mm	8	8	8	8	8	8	8	8	8
K mm (6xM8)	448	510	550	550	585	666	666	716	830
L mm	20	20	20	20	20	20	20	20	25
M mm	-	140	-	-	-	150	-	-	-
N	G 3/8	G 3/8	G 3/8	G 3/8	G 3/8	G 1/2	G 1/2	G 1/2	G 1/2
O mm	37	37	37	37	37	39,5	39,5	39,5	44,5
P mm	26	26	26	26	26	33	33	33	33
a mm	57	57	57	57	57	75	75	75	75
bH7 mm	25,5	25,5	25,5	25,5	25,5	30	30	30	30
c inch	3/32"x90°	3/32"x90°	3/32"x90°	3/32"x90°	3/32"x90°	3/32"x90°	3/32"x90°	3/32"x90°	3/32"x90°
d	M20x50	M20x50	M20x50	M20x50	M20x50	M24x60	M24x60	M24x60	M24x60
e mm	20	20	20	20	20	28	28	28	28
f min.	32	32	32	32	32	42	42	42	42
f max.	80	80	95	95	90	95	95	95	120
g mm	112	112	130	130	125	140	140	140	170
h min.	126	132,6	142,1	154,6	177,1	182,6	202,6	227,6	234,6
h max.	145	158	167,5	180	202,5	208	228	253	260
α degree	30°	30°	30°	30°	30°	30°	30°	30°	30°
β degree	15°	15°	15°	15°	15°	15°	15°	15°	15°
γ degree	60°	60°	60°	60°	60°	60°	60°	60°	60°
Min. operating pressure bar	2	2	2	2	2	2	2	2	3
Max. operating pressure bar	8	8	8	8	8	8	8	8	8
Total clamping force at 6 bar kN	120	150	190	170	180	185	180	200	325
Cylinder surface area cm ²	700	862	1003	895	958	1203	1181	1307	2121
Air consumption (total stroke) l	32	42	48	45	46	58	57	63	113
Max. admissible speed min ⁻¹	1500	1300	1200	1200	1100	900	800	750	750
Moment of inertia kgm ²	6.50	8.75	15.50	15.00	19.00	30.50	35.25	45.75	84.50
Weight kg	200	267	348	334	356	515	505	554	785

LVE - large through-hole, with pressure control device, rapid and clamping jaw movement

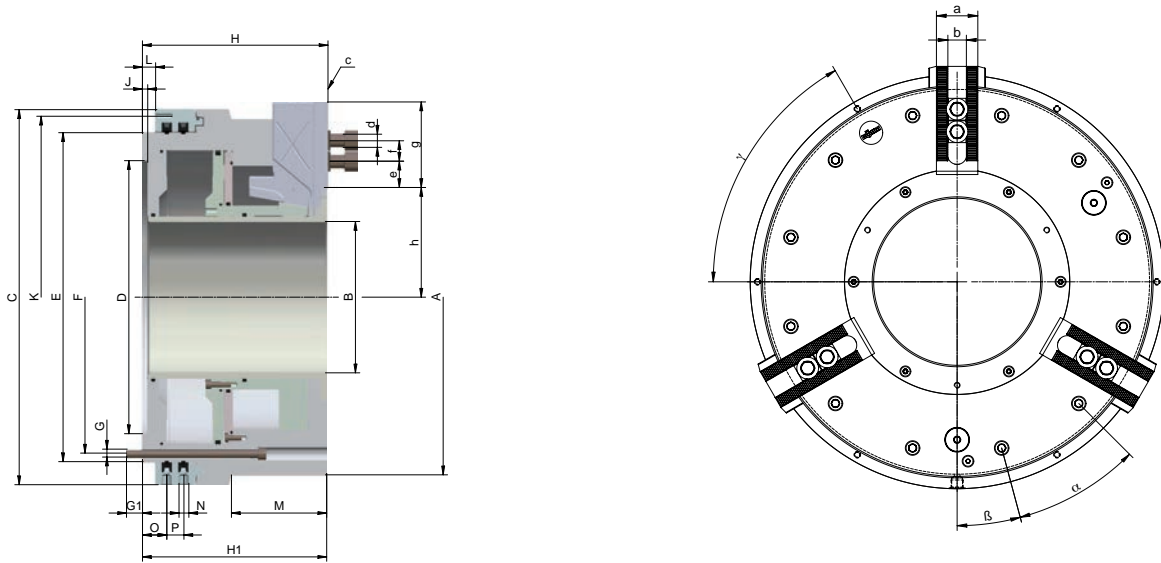

C 15
3-jaw self-contained chucks LVE, with rapid and gripping jaw movements, with large through-hole, external chucking, max. operating pressure 8 bar, with serration
 Cylindrical centre mount with pressure control device for external clamping

Item No.	169433 ▲	169434 ▲	169435 ▲	169436 ▲	169437 ▲	169438 ▲	169439 ▲	169440 ▲	169442 ▲
Size	400	400	500	500	600	600	600	700	800
LVE	LVE 470-140 ES	LVE 490-185 ES	LVE 570-205 ES	LVE 570-230 ES	LVE 600-275 ES	LVE 640-275 ES	LVE 680-325 ES	LVE 730-375 ES	LVE 850-410 ES
Jaw travel mm	19	25,4	25,4	25,4	25,4	25,4	25,4	25,4	25,4
Rapid movement mm	12	16,9	16,9	16,9	16,9	16,9	16,9	16,9	14,9
Gripping movement mm	7	8,5	8,5	8,5	8,5	8,5	8,5	8,5	10,5
A mm	470	490	570	570	605	645	685	735	850
B mm	140	185	205	230	275	275	325	375	410
C mm	470	530	570	570	605	685	685	735	850
D ⁶ mm	310	365	415	415	450	510	510	560	700
E mm	400	460	500	500	535	610	610	660	775
F mm	374	434	474	474	508	580	580	630	745
G mm	M12	M12	M12	M12	M12	M16	M16	M16	M16
G1 mm	25	25	25	25	25	30	30	30	30
H mm	240	282	282	282	282	308	308	308	322
H1 mm	238	280	280	280	280	306	306	306	320
J mm	8	8	8	8	8	8	8	8	8
K mm (6xM8)	448	510	550	550	585	666	666	716	830
L mm	20	20	20	20	20	20	20	20	25
M mm	-	140	-	-	-	150	-	-	-
N	G 3/8	G 3/8	G 3/8	G 3/8	G 3/8	G 1/2	G 1/2	G 1/2	G 1/2
O mm	37	37	37	37	37	39,5	39,5	39,5	44,5
P mm	26	26	26	26	26	33	33	33	33
a mm	57	57	57	57	57	75	75	75	75
bH7 mm	25,5	25,5	25,5	25,5	25,5	30	30	30	30
c inch	3/32"x90°	3/32"x90°	3/32"x90°	3/32"x90°	3/32"x90°	3/32"x90°	3/32"x90°	3/32"x90°	3/32"x90°
d	M20x50	M20x50	M20x50	M20x50	M20x50	M24x60	M24x60	M24x60	M24x60
e mm	20	20	20	20	20	28	28	28	28
f min.	32	32	32	32	32	42	42	42	42
f max.	80	80	95	95	90	95	95	95	120
g mm	112	112	130	130	125	140	140	140	170
h min.	126	132,6	142,1	154,6	177,1	182,6	202,6	227,6	234,6
h max.	145	158	167,5	180	202,5	208	228	253	260
α degree	30°	30°	30°	30°	30°	30°	30°	30°	30°
β degree	15°	15°	15°	15°	15°	15°	15°	15°	15°
γ degree	60°	60°	60°	60°	60°	60°	60°	60°	60°
Min. operating pressure bar	2	2	2	2	2	2	2	2	3
Max. operating pressure bar	8	8	8	8	8	8	8	8	8
Total clamping force at 6 bar kN	120	150	210	170	180	185	180	200	325
Cylinder surface area cm ²	700	862	1024	895	958	1203	1181	1307	2121
Air consumption (total stroke) l	32	42	50	45	46	58	57	63	113
Max. admissible speed min ⁻¹	1500	1300	1200	1200	1100	900	800	750	750
Moment of inertia kgm ²	6,50	8,75	15,50	15,00	19,00	30,50	35,25	45,75	84,50
Weight kg	200	267	348	334	356	515	505	554	785

Jaws LVE

C 21

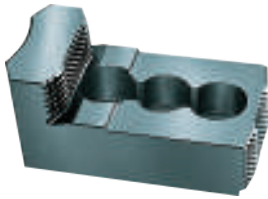
Reversible top jaws, 3-jaw set, hardened serration 90° - material: 16MnCr5

Chuck Size	3-jaw set	Jaw length mm	Jaw height mm	Jaw width mm	Serration
400/500/600	037531	135	65	68	3/32"x 90°
600/700	169464	170	75	80	3/32"x90°
800	169466	195	85	80	3/32"x90°

Additionally or later applied, hardened jaws must be ground out in the chuck.

C 21

Extended soft top jaws, 3-jaw set serration 90° - material: 16MnCr5

Chuck Size	3-jaw set	Jaw length mm	Jaw height mm	Jaw width mm	Serration
400	137028	180	80	50	3/32"x 90°
500/600	169449	205	80	50	3/32"x90°
600/700	169452	245	89	68	3/32"x90°
800	169456	285	89	68	3/32"x90°

Accessories LVE

C 15 T-nuts With screw

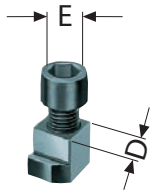

Item no.	Chuck Size	Contents of delivery	D mm	E
1305181 ▲	400/500/600	piece	25,5	M20x50
1305182 ▲	600/700/800/1000	piece	30	M24x60

C 15 Pneumatic control unit for LVE 400-1000



Item no.	Width mm	Height mm	Depth mm	Control voltage	Connection	Weight approx. kg
426560	280	250	100	24 V	R 1/2 inside thread	3

When double chucks are used, two pneumatic control devices are required

C 15 Control units for single chucks with dual foot switch, wired, cable length 6 meters, for LVE 400-1000



Item no.	Design	Width mm	Height with plug mm	Height mm	Depth mm	Control voltage	Cable length
426481	without pressure monitoring	300	340	300	125	24 V	6 m
426263	with pressure monitoring	300	340	300	125	24 V	6 m

Power supplies on request: primary 35-264 V ~, 47-63 Hz - secondary 24V/1.5 A

C 15 Control units for dual chucks with dual foot switch, wired, cable length 6 meters, for LVE 400-1000



Item no.	Design	Width mm	Height with plug mm	Height mm	Depth mm	Control voltage	Cable length
426482 ▲	without pressure monitoring	300	340	300	125	24 V	6 m
426264 ▲	with pressure monitoring	300	340	300	125	24 V	6 m

Power supplies on request: primary 35-264 V ~, 47-63 Hz - secondary 24V/1.5 A

Jaw dimensions und chucking capacities LVE

Reversible top jawsUB

serration 90°,
material 16MnCr5

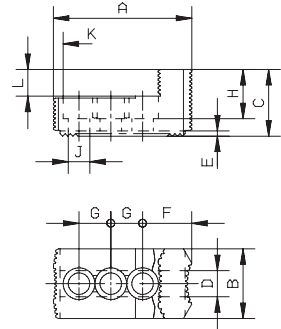

Chuck size	400		500		600		700	800			
LVE	420-140	480-185	540-205	570-230	600-275	630-275	680-325	730-375	800-375	830-410	
Type	538-07		538-07		538-07	543-21		543-21	543-21		
Item no. 3-jaw set	037531		037531		037531	169464		169464	169466		
A	135	135	135	135	135	170	170	170	195	195	
B	68	68	68	68	68	80	80	80	80	80	
C	65	65	65	65	65	75	75	75	85	85	
D+0,05	25,5	25,5	25,5	25,5	25,5	30,0	30,0	30,0	30,0	30,0	
E	5	5	5	5	5	6	6	6	6	6	
F	48	48	48	48	48	57	57	57	78,5	78,5	
G	31+31	31+31	31+31	31+31	31+31	42+42	42+42	42+42	42+42	42+42	
H	48	48	48	48	48	58	57	57	62	62	
J	21	21	21	21	21	25	25	25	26	26	
K	31	31	31	31	31	38	38	38	40	40	
L	26	26	26	26	26	32	32	32	35	35	
M	--	--	--	--	--	--	--	--	--	--	
Serration	3/32"x90°		3/32"x90°		3/32"x90°	3/32"x90°		3/32"x90°	3/32"x90°		
Weight/jaw kg	2,4		2,4		2,4	3,9		3,9	5,6		
External chucking	A1	85 - 255	135 - 305	160 - 370	180 - 390	220 - 430	225 - 420	265 - 460	315 - 510	280 - 530	315 - 565
	A2	125 - 295	175 - 345	200 - 410	220 - 430	260 - 470	275 - 470	315 - 510	365 - 560	370 - 620	405 - 655
	A3	330 - 500	380 - 550	405 - 615	425 - 635	465 - 675	540 - 735	580 - 775	630 - 825	640 - 890	675 - 925
Internal chucking	J1	155 - 325	205 - 375	230 - 440	250 - 460	290 - 500	305 - 500	345 - 540	395 - 590	405 - 655	440 - 690
	J2	350 - 520	405 - 570	430 - 640	450 - 660	490 - 700	565 - 770	605 - 800	655 - 850	670 - 920	705 - 955
max. interferences diameter	S	570	625	690	710	750	800	840	890	1000	1030

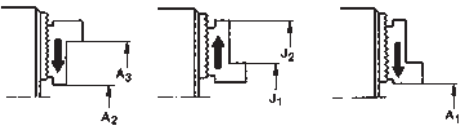

Extended soft top jaws AB

serration 90°,
material 16MnCr5

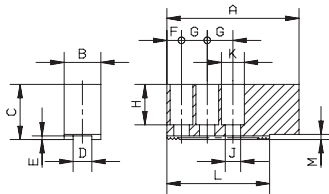

Chuck size	400		500		600		700	800		
LVE	420-140	480-185	540-205	570-230	600-275	640-275	680-325	730-375	800-375	830-410
Type	518-07		543-22		543-22	543-22		543-22	543-22	
Item no. 3-jaw	137028		169449		169449	169452		169452	169456	
A	180	180	205	205	205	245	245	245	285	285
B	50	50	50	50	50	68	68	68	68	68
C	80	80	80	80	80	89	89	89	89	89
D+0,05	25,5	25,5	25,5	25,5	25,5	30,0	30,0	30,0	30,0	30,0
E	5	5	5	5	5	6	6	6	6	6
F	20	20	20	20	20	25	25	25	25	25
G	35+35	35+35	35+35	35+35	35+35	45+45	45+45	45+45	55+55	55+55
H	60	60	60	60	60	69	69	69	69	69
J	21	21	21	21	21	25	25	25	25	25
K	31	31	31	31	31	37	37	37	37	37
L	180	180	190	190	190	140	140	140	160	160
M	--	--	6	6	6	7	7	7	7	7
Toothing	3/32"x90°		3/32"x90°		3/32"x90°	3/32"x90°		3/32"x90°	3/32"x90°	
Weight/jaw kg	4,2		5,0		5,0	9,1		9,1	10,9	
A1 Ø External chucking	20 - 155	30 - 200	10 - 220	30 - 240	75 - 285	60 - 255	100 - 295	150 - 345	105 - 355	140 - 390
S Ø max. interference diameter	330	575	640	660	710	760	800	850	945	980



Notes

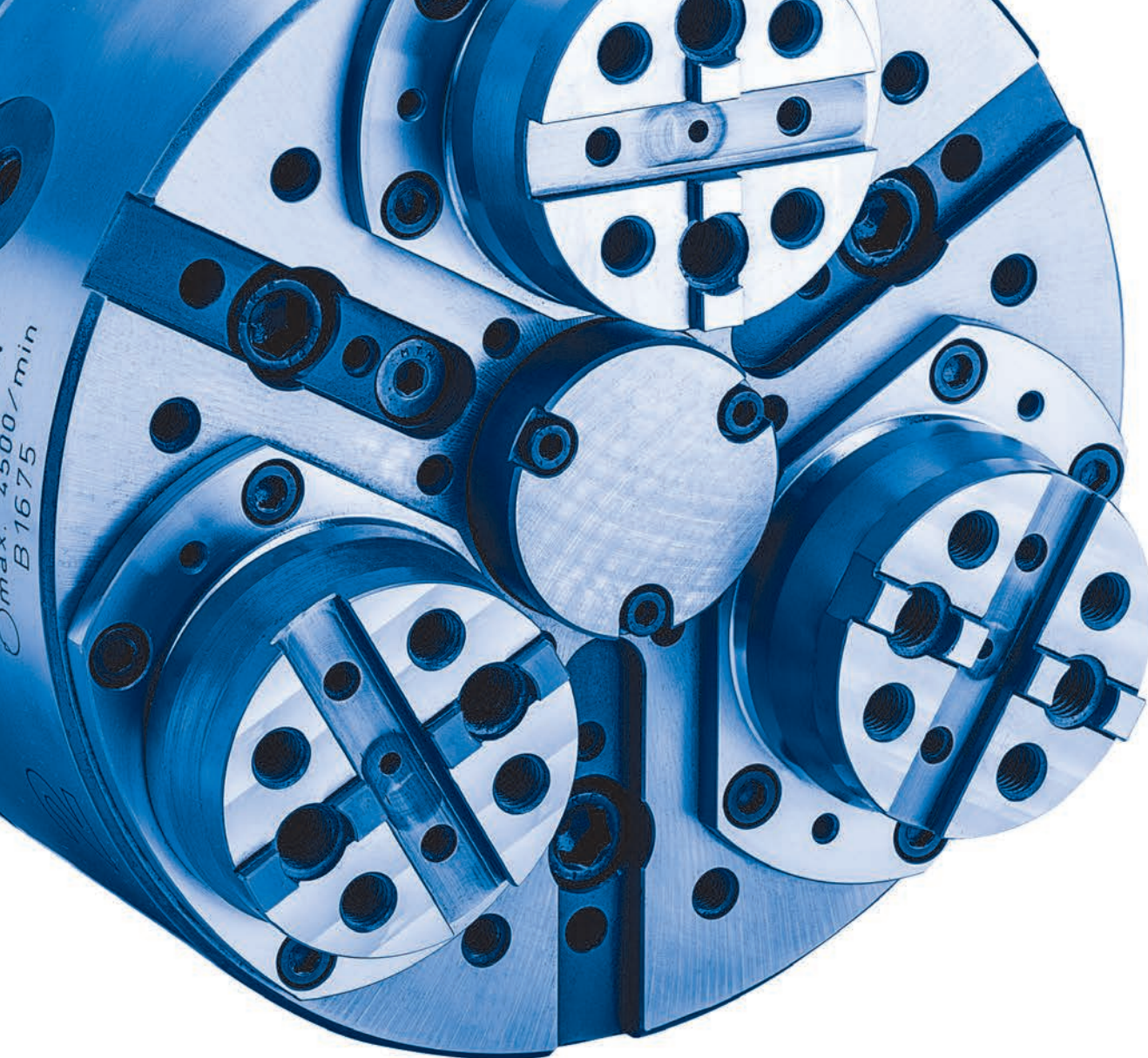

THE RIGHT CHUCK FOR EVERY APPLICATION



KBF-N draw-down
power chuck



ZFM draw-down
power chuck



KFD-AF compensating
chuck



GF gripper chuck

The RÖHM application chucks are as versatile as the sectors where they are used. RÖHM application chucks are used successfully in the sectors of mechanical engineering, the automobile industry, for aerospace, as well as the energy sector to Micro Technology sector.



Video KBF-N draw-down
power chuck

APPLICATION CHUCKS

RÖHM application chucks are specially developed for the requirements of the respective sector and their applications in order to ensure top quality, reliability and safety. The application chucks are used successfully in the sectors of mechanical engineering, the automobile industry, for aerospace, as well as the energy sector to Micro Technology sector.

ADVANTAGES AT A GLANCE

- ⊕ Safe and precise clamping of complex and individual workpieces
- ⊕ Adaptation of the clamping solution to the individual application
- ⊕ Proven RÖHM quality for maximum reliability

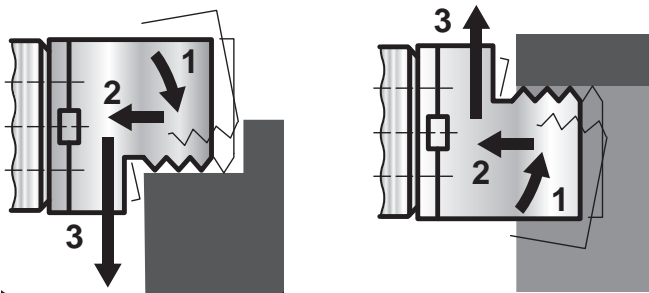

Functionality of the draw-down power chucks (KBF-N and ZFM):

The workpiece is automatically drawn down onto a rigid plane face when it is clamped. In the process, the workpiece is moved and fixed by clamping jaws during the clamping-operation, before the clamping force is built up again in this axially defined position. Depending on the functional principle of the clamping chuck, internal and external clamping or external clamping only can be realized.

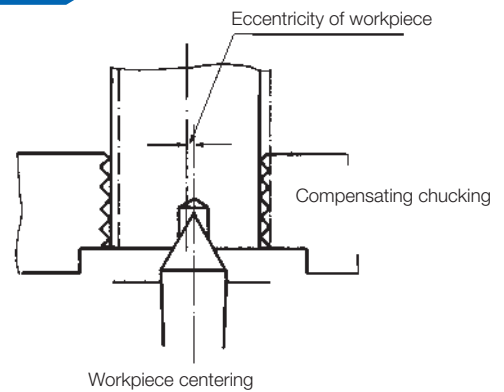

Functionality of the compensating chuck (KFD-AF):

The workpiece is taken up in the center point which is mounted in an insert, and clamped by centrally compensating jaws. Compensation is realized by the radially floating, chucking piston. By simply exchanging the center insert, the chuck can be very quickly retrofit to centric clamping.

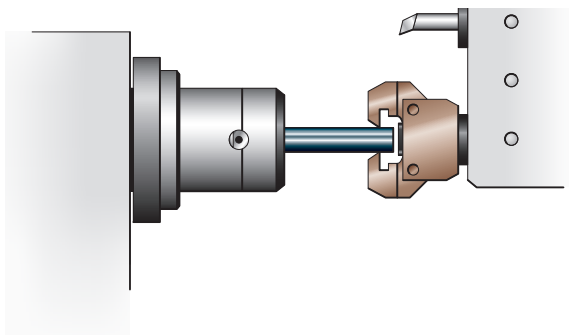

Functionality of gripper chucks (GF):

To clamp, the gripper chuck is usually moved against the clamped-in material with the tool holder of the machine. In the process, the jaws are forced outward via their approach angle until the workpiece diameter is reached and they grab the workpiece in the cylindrical area. The clamping force is generated by a floating disc spring package acting on the jaws. The round material is now released in the clamping chuck and pulled into the intended position by the gripper chuck. Now the workpiece is clamped again and the gripper chuck simply pulled off by the workpiece. The jaws are automatically pressed inward into their original position by the disc spring package. The interchangeable take-up shaft meets DIN 69880.

KBF-N - maximum plane-parallelism



APPLICATION

For clamping tasks for internal and external clamping where the axial run-out errors of the workpiece have to be minimized.

TYPE

Power chuck with draw-down and ball lock principle available with cylindrical centre mount or short taper mount.

CUSTOMER BENEFITS

- ⊕ Maximum plane-parallelism thanks to active draw-down by the jaws
- ⊕ Maximum productivity thanks to long maintenance intervals - hermetically sealed against dirt and cooling water
- ⊕ Consistent workpiece quality thanks to constant clamping force due to oil filling
- ⊕ Suitable for high speeds (speed-dependent centrifugal influences are minimized by similar mass distribution to the right and left of the ball lock)

TECHNICAL FEATURES

- Ball lock principle with wedge hook system
- With fixed jaws (pendulum jaws on request)

Note:

Alternatively with swinging ball lock for clamping rough, easily deformable workpieces at six clamping points on request

Included in scope of delivery:

Chuck, chuck mounting screws (without top jaws)

KBF-N = ball lock, chuck, draw-down



Power-operated ball lock draw-down chuck

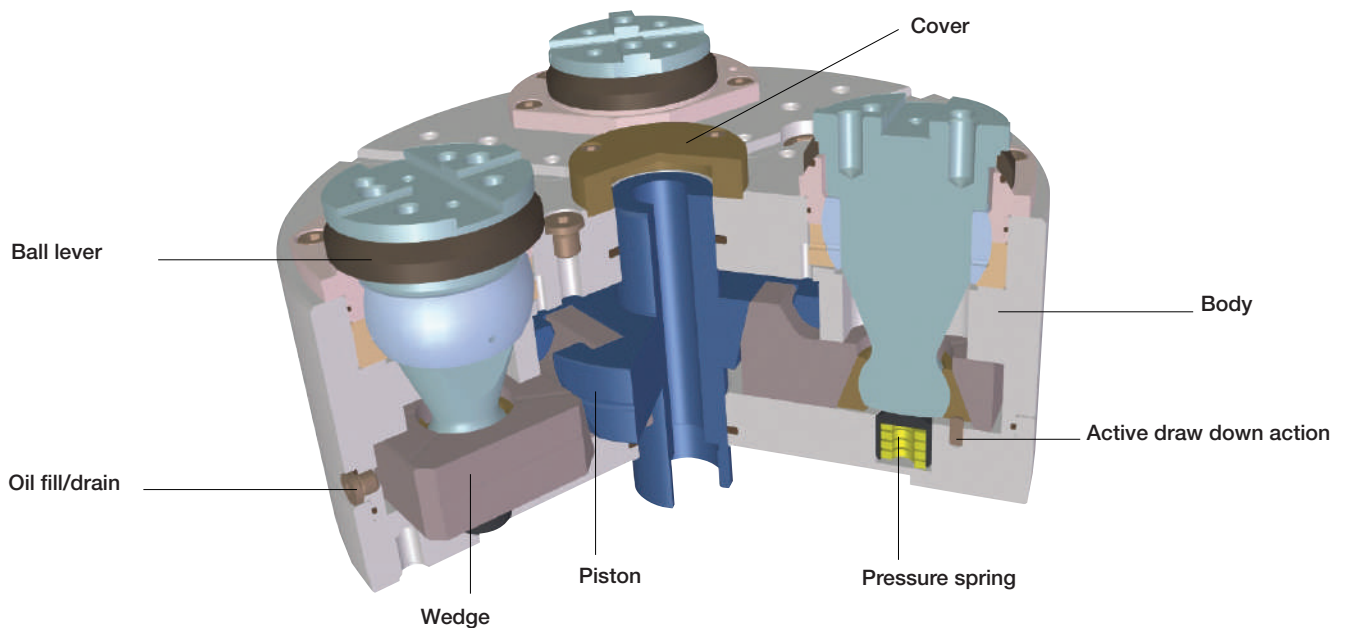

KBF-N - maximum plane-parallelism

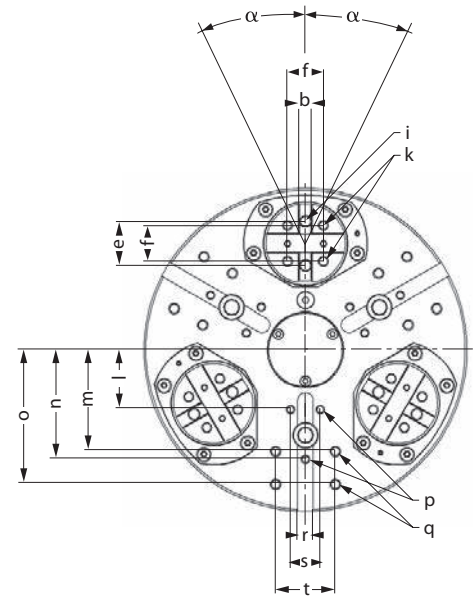
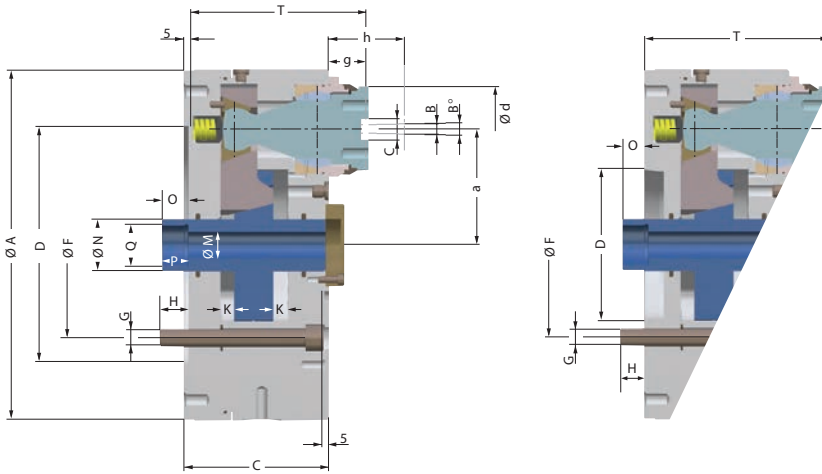

C 15
 Power-operated ball lock draw-down chuck **KBF-N** with **fixed jaws** for **internal and external clamping**, with pull down effect, **hermetically sealed, oil filled, central clamping**
 Cylindrical centre mount **DIN 6353**

Item No.	168355 ▲	165635 ▲	165637 ▲	165639 ▲	168056 ▲
Size	170	200	250	315	400
Jaw design	Fixed jaws	Fixed jaws	Fixed jaws	Fixed jaws	Fixed jaws
A mm	178	210	260	325	400
Jaw travel B mm	5,4	5,9	6,3	6,4	7,5
B°	5,2°	4,9°	4,4°	4,5°	4,7°
C mm	94	111	135	135	148
D	ZA 140	ZA 170	ZA 220	ZA 220	ZA 300
F mm	104,8	133,4	171,4	171,4	235
G	3 x M10	3xM12	3xM16	3xM16	3 x M20
H mm	15	17	22	22	30
Total wedge stroke K+K mm	21	25	25	25	30
M mm	14	14	18	25	52
N ^ø mm	30	36	38	48	75
O min.	12,5	12,5	12,5	12,5	10
O max.	33,5	37,5	37,5	37,5	40
P mm	20	18	20	25	25
Q mm	M22 x 1,5	M28x1,5	M32x1,5	M38x1,5	M60 x 1,5
T mm	116	139	163	163	180
a mm	55	64	82	107	130
bh8 mm	7,94	7,94	12,7	12,7	12,7
cH7 mm	12,68	12,68	19,03	19,03	19,03
d mm	60	65	75	80	105
e mm	32	38	44,4	44,4	63,5
f mm	24	32	36	36	48
g mm	27	33	33	33	37
Reference height h mm	50	60	70	70	80
i	M10	M12	M12	M12	M16
k	M8	M10	M10	M10	M12
l mm	-	30	50	60	80
m mm	65	80	102	102	140
n mm	68	50	65	110	144
o mm	-	-	-	135	170
p	M6	M6	M8	M8	M10
q	M8	M8	M10	M10	M12
r mm	16	16	16	16	20
s mm	-	25	30	30	36
t mm	36	45	60	60	80
Pull-down travel mm	0,3	0,3	0,3	0,3	0,3
Max. admissible speed min ⁻¹	5000	4500	3800	3000	2200
Maximum draw bar pull kN	18	30	40	45	50
Max. total clamping force kN	44	73	93	105	120
Weight approx. kg	18	30	55	80	130
Actuating cylinders (recommended)	OVS-85	OVS-105	OVS-130	OVS-130	OVS-150

Power-operated ball lock draw-down chuck

KBF-N - maximum plane-parallelism

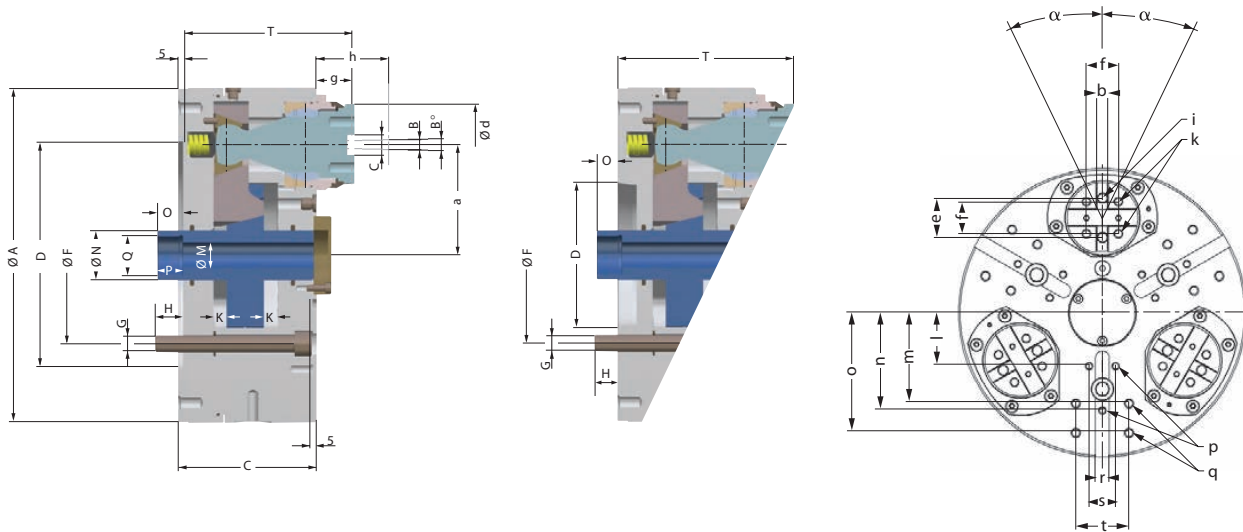

C 15

 Power-operated ball lock draw-down chuck **KBF-N** with **fixed jaws** for internal and external clamping, hermetically sealed, oil filled, central clamping
 Short taper mount for **ISO 702-1** (DIN 55026/55021)

Item No.	168356 ▲	165636 ▲	165638 ▲	165640 ▲	168057 ▲
Size	170	200	250	315	400
Jaw design	Fixed jaws	Fixed jaws	Fixed jaws	Fixed jaws	Fixed jaws
A mm	178	210	260	325	400
Jaw travel B mm	5,4	5,9	6,3	6,4	7,5
B°	5,2°	4,9°	4,4°	4,5°	4,7°
C mm	94	111	135	135	148
D	KK 5	KK 6	KK 8	KK 8	KK 11
F mm	104,8	133,4	171,4	171,4	235
G	3 x M10	3xM12	3xM16	3xM16	3 x M20
H mm	15	17	22	22	30
Total wedge stroke K+K mm	21	25	25	25	30
M mm	14	14	18	25	52
N ^ø mm	30	36	38	48	75
O min.	7,5	7,5	7,5	7,5	5
O max.	28,5	32,5	32,5	32,5	35
P mm	20	18	20	25	25
Q mm	M22 x 1,5	M28x1,5	M32x1,5	M38x1,5	M60 x 1,5
T mm	121	144	168	168	185
a mm	55	64	82	107	130
bh8 mm	7,94	7,94	12,7	12,7	12,7
cH7 mm	12,68	12,68	19,03	19,03	19,03
d mm	60	65	75	80	105
e mm	32	38	44,4	44,4	63,5
f mm	24	32	36	36	48
g mm	27	33	33	33	37
Reference height h mm	50	60	70	70	80
i	M10	M12	M12	M12	M16
k	M8	M10	M10	M10	M12
l mm	-	30	50	60	80
m mm	65	80	102	102	140
n mm	68	50	65	110	144
o mm	-	-	-	135	170
p	M6	M6	M8	M8	M10
q	M8	M8	M10	M10	M12
r mm	16	16	16	16	20
s mm	-	25	30	30	36
t mm	36	45	60	60	80
Pull-down travel mm	0,3	0,3	0,3	0,3	0,3
Max. admissible speed min ⁻¹	5000	4500	3800	3000	2200
Maximum draw bar pull kN	18	30	40	45	50
Max. total clamping force kN	44	73	93	105	120
Weight approx. kg	18	30	55	80	130
Actuating cylinders (recommended)	OVS-85	OVS-105	OVS-130	OVS-130	OVS-150

Jaws KBF-N

C 21

Soft top jaws, 3-jaw set tongue and groove, material: 16MnCr5



Item no.	Chuck Size	Jaw length mm	Jaw height mm	Jaw width mm
168383▲	170	70	26,5	60
165694	200	80	31,5	65
165696▲	250/315	90	41,5	75
168385▲	400	125	46,5	105

Workpiece-specific top jaws can be placed on the tongue and groove interface of the ball bolts.

For exact clamping, soft top jaws are preferably used. They are to be turned out to the desired clamping diameter under clamping force. If these top jaws are still to be hardened, the chuck must be ground out afterward.

For raw-part clamping, hardened clamping inserts can be worked into the soft top jaws at the corresponding clamping diameter.

On request, special top jaws specific to the workpiece can also be delivered.

Soft top jaws for KBF-N

Chuck size	170	200	250	315	400
A	70	80	90	90	125
B	60	65	75	75	105
C	26,5	31,5	41,5	41,5	46,5
D	20	20	30	30	30
E	25	30	30	30	40
b H7	7,94	7,94	12,7	12,7	12,7
c h6	12,68	12,68	19,03	19,03	19,03
f	24	32	36	36	48

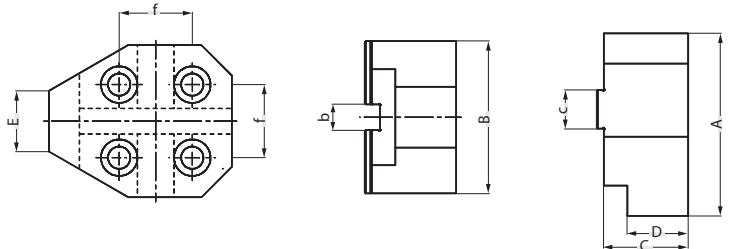

Examples for machined clamping jaws

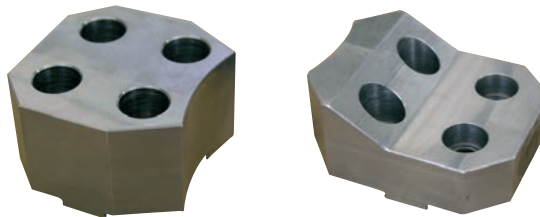

Examples for applications:

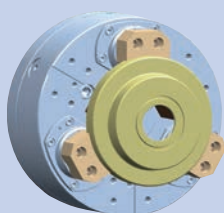

Fixed jaws:
For exact clamping of flange-like workpieces, e.g. wheel hubs, spur gears, etc.

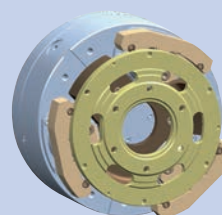

Optionally with pendulum jaws:
For clamping deformation-sensitive raw parts, e.g. coupling pressure plates or sprockets

ZFM - with pull-down



APPLICATION

Simple clamping principle for external clamping of bars, pipes and shafts, as well as flange-type workpieces where the axial run-out errors of the workpiece have to be minimized.

TYPE

Collet pin system with cylindrical centre mount.

CUSTOMER BENEFITS

- ⊕ Maximum plane-parallelism thanks to active draw-down using axially movable draw rod studs
- ⊕ Easy adaptation to various workpiece diameters thanks to interchangeable clamping inserts
- ⊕ Insensitive clamping system thanks to simple setup, allows machining at maximum speeds

TECHNICAL FEATURES

- Power transmission directly from the piston to the draw rod studs
- Clamping inserts hardened, adapted to the workpiece diameter

Included in the scope of delivery:

Chuck, chuck and jaw mounting screws, mounting wrench (without top jaws)



Special designs:

E.g. power operated draw bar chuck ZFM, diameter 220 mm, with clamping inserts with chip flow grooves and threads, for work stops for clamping of aluminum flanges.

ZFM - with pull-down

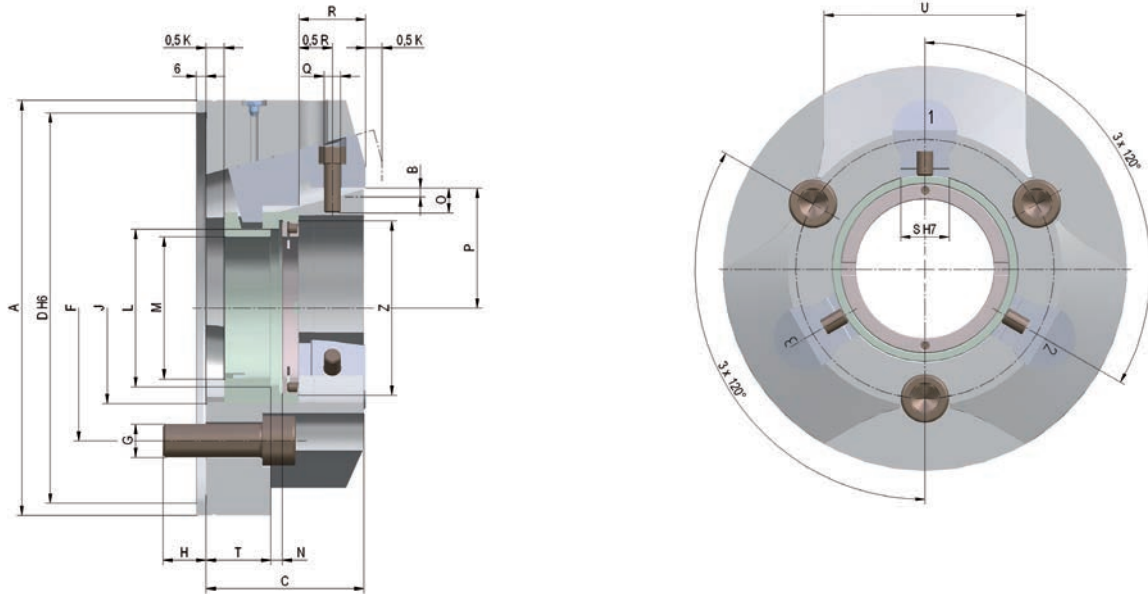

C 15
Power-operated draw bar chuck **ZFM**, with gripping inserts, cylindrical centre mount

Item No.	201980 ▲	201981 ▲	201982 ▲	201983 ▲
Size	160	200	250	315
A mm	160	200	250	315
Jaw travel B mm	5,3	5,3	5,3	5,3
C mm	75	82	95	105
D ⁶ mm	145	185	235	235
F mm	100	140	160	200
G	3 x M 12	3 x M 16	3 x M 20	3 x M 20
H mm	18	20	26	26
J mm	71	95	115	160
Wedge stroke K mm	20	20	20	20
L mm	52	72	95	136
M mm	45,5	65,5	85,5	125,5
N mm	7	7	7	7
O mm	12	15	15	15
P max.	48,15	64,65	74,65	101,65
P min.	42,85	59,35	69,35	96,35
Q mm	M 8	M 10	M 10	M 12
R mm	30	35	40	45
SH7 mm	24	30	30	35
T max.	40	40	48	53
T min.	20	20	28	33
U mm	60	85	125	125
Z	M 62 x 1,25	M 85 x 1,25	M 105 x 1,25	M 150 x 1,25
Maximum draw bar pull kN	25	35	45	50
Max. total clamping force approx. kN	46	66	84	90
Max. admissible speed min ⁻¹	8000	6300	5500	4200
Moment of inertia J kgm ²	0,026	0,072	0,183	0,508
Weight without jaw inserts approx. kg	7,5	13	21	35
Chucking capacity mm	0-40	4-70	24-80	30-130
Actuating cylinders (recommended)	OVS-85/105	OVS-105	OVS-130	OVS-150

C 21
Clamping Jaws, 3-jaw-set, prefabricated, can be hardened material: 16MnCr5



Chuck Size	3-jaw set	Jaw length mm	Jaw height mm	Jaw width mm
160	210007 ▲	42,7	30	24
200	210008 ▲	51,7	35	30
250	210009 ▲	61,7	45	30
315	210010 ▲	85,7	45	35

Power-operated draw bar chuck ZFM

KFD-AF - compensating jaws



APPLICATION

Centric or compensating clamping chuck with which the workpiece is centered either via a center or via the jaws.

TYPE

Compensating clamping power chuck with cylindrical centre mount or short taper mount.
3-jaw version with serration 90°.

CUSTOMER BENEFITS

- ③ Flexible use thanks to retrofitting to centric clamping using center inserts
- ③ Low-maintenance thanks to special sealing against dirt and cooling water

TECHNICAL FEATURES

- Proven wedge hook system
- Compensation is realized by the radially floating chucking piston
- Piston lubrication at centric clamping
- Base jaw lubrication

Note:

When ordering, please specify power chuck, center insert and mounting flange

Included in the scope of delivery:

Chuck, chuck and jaw mounting screws, slot nuts (without top jaws)

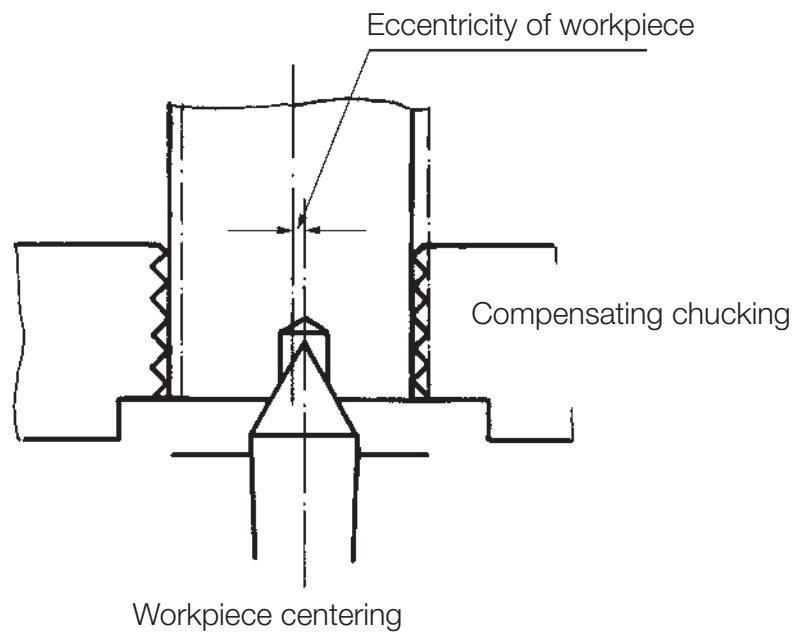

Functionality of the compensating chuck (KFD-AF):

The workpiece is taken up in the center point which is mounted in an insert, and clamped by centrally compensating jaws. Compensation is realized by the radially floating chucking piston. By simply exchanging the center insert, the chuck can be very quickly retrofit to centric clamping.

Interchangeable centering inserts:

- with spring-loaded center
- with solid center
- for self-centering chucking (no compensation)

Interchangeable mounting adapters:

- with cylindrical mount
- with short taper recess
- with option for radial fine adjustment, upon request

KFD-AF - compensating jaws

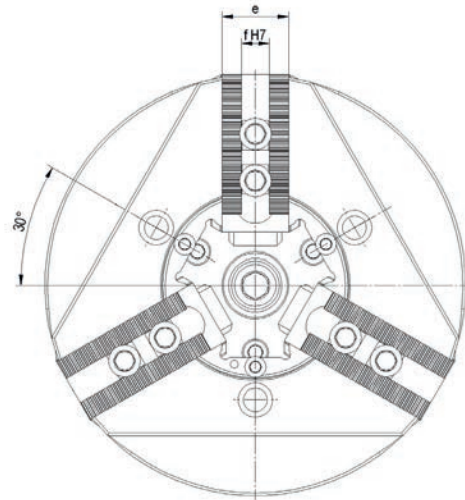
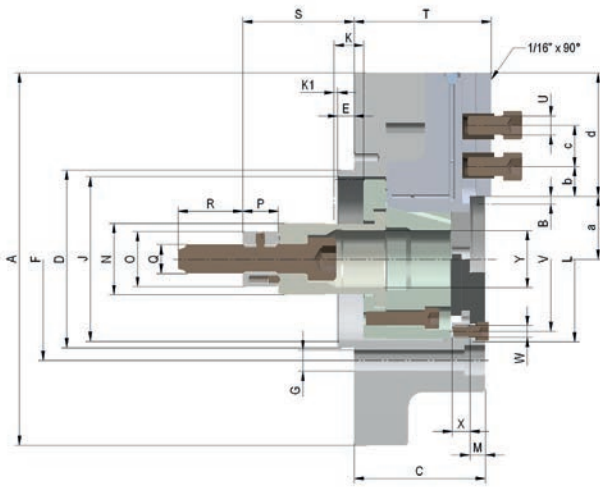

C 15
3-jaw compensation chucks **KFD-AF**, with serration 90°, center insert and chuck mount interchangeable

Item No.	144620	144621	144622	144623
Size	160	200	250	315
A mm	160	200	250	315
Jaw travel B mm	4,8	5,6	6,7	6,7
C mm	78	85	93	111
D ⁹⁶ mm	90	115	135	150
E mm	14	14	14	14
F mm	104,8	133,4	171,4	171,4
G mm	3 x ø 12	3 x ø 14	3 x ø 18	3 x ø 18
J mm	82	103	122	139
Wedge stroke K mm	18	21	25	25
K, mm	2	2	3	3
L ^{H6} mm	90	95	120	140
M mm	10	11	13	13
N ⁹⁶ mm	38	42	50	60
O mm	34	40	46	46
P mm	25	30	30	30
Q mm	M16	M20	M24	M24
R mm	40	45	55	55
S min.	56	75	94	94
S max.	74	96	119	119
T mm	82	90	98	116
U	M12	M12	M16	M16
V mm	72	80	102	102
W mm	3 x M8	3 x M8	3 x M10	3 x M10
X mm	12	15	15	15
Y ^{H6} mm	32	32	38	48
a min.	27,2	34,4	40,3	46,3
a max.	32	40	47	53
b min.	8	8	10	10
c min.	19	19	25	25
c max.	37	49	64	90
d mm	48	60	78	104,5
e mm	35	40	50	50
f ^{H7} mm	17	17	21	21
Maximum draw bar pull kN	25	36	50	65
Max. total clamping force approx. kN	50	72	110	150
Max. admissible speed min ⁻¹	3500	3200	3000	2300
Compensation on Ø mm	3	3	4	4
Moment of inertia J kgm ²	0,04	0,1	0,218	0,744
Weight without jaws approx. kg	13	20	28	60
Actuating cylinders (recommended)	OVS-85/105	OVS-105	OVS-130	OVS-150

Note: When ordering, specify power chuck, center insert and mounting flange
The diameter N⁹⁶ must be guided in the spindle

Accessories KFD-AF

C 15
Centering insert with spring-loaded centre

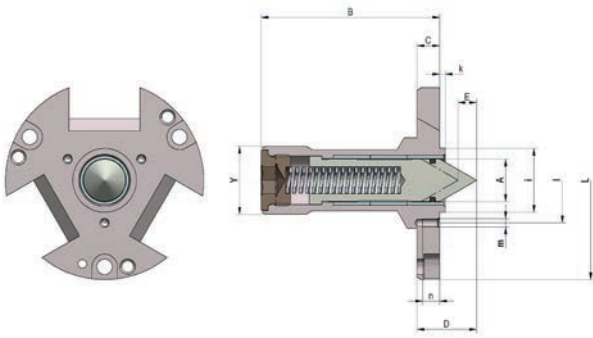

Item no.	Size	A mm	B mm	C mm	D mm	E mm	Lj6 mm	i-0,05 mm	k mm	Yg6 mm	l mm	m	n mm
144624 ▲	160	17,5	90	13	~30	6	90	30	4	32	40	M 5	8
144625 ▲	200	20,5	91	14	~33	8	95	30	4	32	40	M 5	10
144626 ▲	250	25,5	109	16	~38	10	120	40	4	38	50	M 5	10
144627 ▲	315	30,5	125	16	~42	13	140	45	4	48	60	M 6	12

C 15
Centering insert with fixed centre

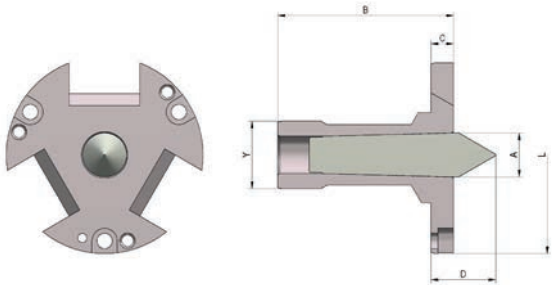

Item no.	Size	A mm	B mm	C mm	D mm	Lj6 mm	Yg6 mm
144628 ▲	160	~18	90	13	~33	90	32
144629 ▲	200	~18	91	14	~33	95	32
144630 ▲	250	~24	109	16	~38	120	38
144631 ▲	315	~32	125	16	~46	140	48

C 15
Centering insert for centric clamping

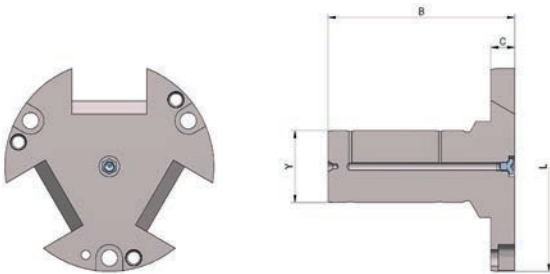

Item no.	Size	B mm	C mm	Lj6 mm	Yg6 mm
144632 ▲	160	90	13	90	32
144633 ▲	200	91	14	95	32
144634	250	109	16	120	38
144635 ▲	315	125	16	140	48

C 21
Reversible top jaws, 3-jaw set, hardened serration 90° - material: 16MnCr5



Item no.	Chuck Size	Jaw length mm	Jaw height mm	Jaw width mm	Serration
046408	160/200	68	45	34,7	1/16"x 90°
118522	160/200	75	49	36	1/16"x 90°
046414	250/315	103,5	58	50	1/16"x 90°

Additionally or later applied, hardened jaws must be ground out in the chuck.

C 21
Soft top jaws, 3-jaw set, can be hardened serration 90° - material: 16MnCr5



Item no.	Chuck Size	Jaw length mm	Jaw height mm	Jaw width mm	Serration
133152	160	66,7	53	36,5	1/16"x 90°
133153	200	75	53	36,5	1/16"x 90°
133154	250	95	54,5	45	1/16"x 90°
133155	315	103	80	50	1/16"x 90°

Further suitable jaws you can find at the KFD power chuck.

Accessories KFD-AF

C 15

Adaptor plates with cylindrical centre mount to DIN 6353 complete with mounting screws

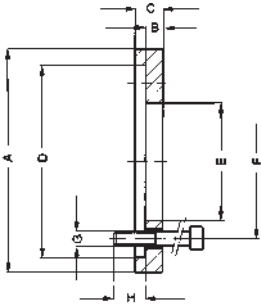

Item no.	Size	A mm	B mm	C mm	D ^ø mm	EH6 mm	F mm	G	H mm
144636▲	160	160	16	22	140	90	104,8	3 x M10	14
144637▲	200	200	16	22	170	115	133,4	3 x M12	16
144638▲	250	250	17	23	220	135	171,4	3 x M16	24
144639▲	315	280	17	23	220	150	171,4	3 x M16	24

C 15

Adaptor plates with short taper mount ISO 702-1 (DIN 55026/55021) complete with mounting studs

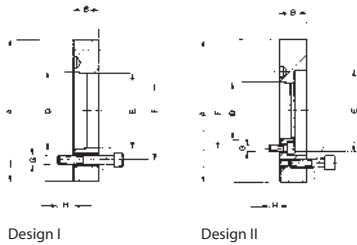

Design I

Design II

Item no.	Size	Design	A mm	B mm	D mm	EH6 mm	F mm	G	H mm
144643	160/5	I	135	29	KK 5	90	104,8	3 x M10	15
144646▲	160/6	III	165	30	KK 6	90	133,4	3 x M12	18
144649	200/5	II	165	33	KK 5	115	104,8	3 x M10	14
144652	200/6	I	165	30	KK 6	115	133,4	3 x M12	18
144655	250/6	II	210	36	KK 6	135	133,4	3 x M12	18
144658	250/8	I	210	33	KK 8	135	171,4	3 x M16	24
144661	315/8	I	210	34	KK 8	150	171,4	3 x M16	25
144664▲	315/11	III	280	46	KK 11	150	235	3 x M20	30

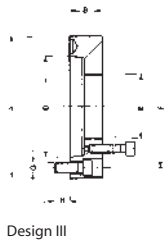

Design III

GF - for cylindrical shank DIN 69880



APPLICATION

Optimal for moving and positioning bar material and pipes in automatic production sequence.

TYPE

2-jaw gripper chuck GF for cylinder shaft DIN69880.

CUSTOMER BENEFITS

- ⊕ Simple, operationally safe system thanks to spring pretensioning with automatic jaw resetting
- ⊕ High efficiency thanks to direct placement on the tool turret without additional actuation device
- ⊕ Simple retrofitting
- ⊕ Clamping jaws can be adapted for special profiles

TECHNICAL FEATURES

- Clamping force by means of disc spring package
- With exchangeable take-up shaft

Included in the scope of delivery:

Chuck, chuck and jaw mounting screws, slot nuts (without top jaws)

GF = gripper, chuck

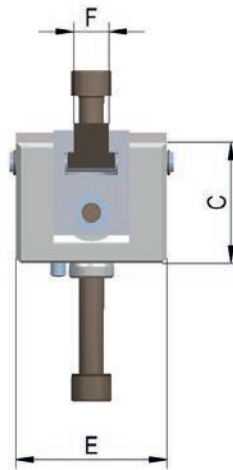
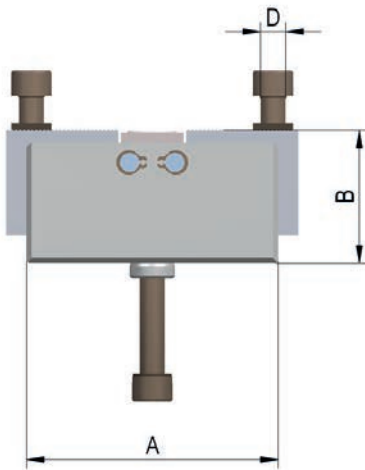
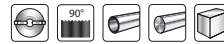

C 15
2-jaw gripper chucks GF for cylindrical shank DIN 69880, chucks without shank, without jaws

Item No.	141077	141078 ▲	141079 ▲
Size	80	100	125
A mm	80	100	125
B mm	50,8	52,8	72,8
C mm	46	48	67
D	M8	M 10	M 10
E mm	50	60	65
f ⁷ mm	12	14	14
Stroke H mm	3	4	4
U	M8	M 10	M 10
Clamping force min. kN	1,3	2	5,3
Clamping force max. kN	1,7	2,7	6

GF - for cylindrical shank DIN 69880

C 15
Cylindrical shank DIN 69880



Item no.	Initial size	Kh6 mm	L mm	M±0,05 mm
156806	25	25	48	23,5
141080 ▲	30	30	55	27
141081	40	40	63	36
141082 ▲	50	50	78	45

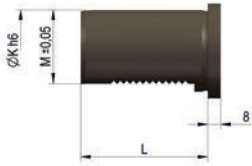

Jaws GF

C 21
Clamping jaws

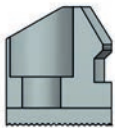

Item no.	Chuck Size	Jaw length mm	Jaw height mm	Jaw width mm
141084	80	28	26	28
141085	100/125	30	34	30

Special applications - rational clamping solutions

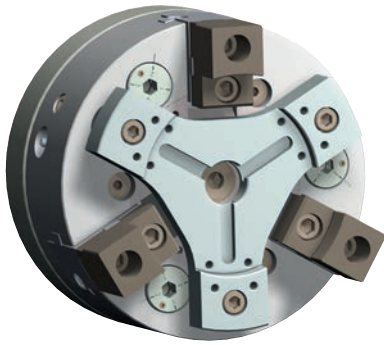

KFD-N draw-down chuck

APPLICATION

Power chucks based on KFD principle with draw-down for clamping tasks for external clamping where workpiece axial run-out errors have to be minimized.

TYPE AND FUNCTION

Retractable chuck body for drawing down the workpiece onto a rigid plane face. Built-in pressure springs put the body back into its original position.

CUSTOMER BENEFITS

- ③ High clamping precision and clamping force by means of the KFD principle
- ③ With active pull-down for maximum plane-parallelism

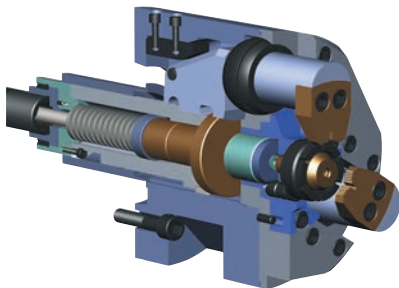

KKHFR combination chuck

APPLICATION

Optimally suited for the complete machining of workpieces, such as crankshafts and cam shafts.

TYPE AND FUNCTION

With retractable clamping jaws and face driver. The clamping jaws are retracted for finish turning; the workpiece is moved by the face driver. This way, the outer diameter can be completely machined. For the force-actuated face driver with a rigid point, the chuck is actuated via the hydraulic double piston cylinder and, in the case of a face driver with spring-loaded point, via the hydraulic clamping cylinder with enlarged stroke.

CUSTOMER BENEFITS

- ③ Efficient complete machining of shafts in one set-up



KTF indexing chuck

APPLICATION

For rationally turning of workpieces with a centric and an eccentric center of rotation (or several eccentric centers of rotation), such as crankshafts, housings or pistons.

TYPE AND FUNCTION

Force-actuated. Clamping and indexing via rotary piston cylinders with 4-way oil distributor in connection with Cardan linkage assembly. Indexing angle 180°. Eccentric dimension constant or adjustable.

CUSTOMER BENEFITS

- ③ Efficient machining of workpieces by shifting the center to be machined without reclamping

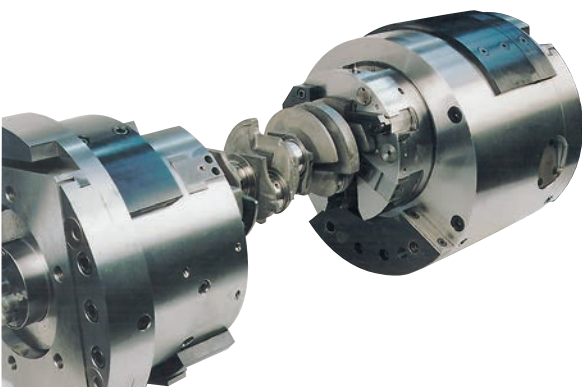

HTF indexing chuck

APPLICATION

Optimally suited for rationally turning workpieces with a centric and an eccentric center of rotation (or several eccentric centers of rotation), such as crankshafts, housings or pistons.

TYPE AND FUNCTION

Hydraulically operated. Indexing is done using 2 hydraulically actuated racks. Clamping by means of integrated hydraulic pistons. Indexing angles 180°, 4x90°, 5x72°, 6x60°.

CUSTOMER BENEFITS

- ③ Efficient machining of workpieces by shifting the center to be machined without reclamping

Special applications - rational clamping solutions



HSF indexing chuck

APPLICATION

For machining workpieces with crossing axes.

TYPE AND FUNCTION

Hydraulically actuated indexing chuck. The swivel axes lie perpendicular to the rotational axis. Oil distributor or clamping cylinder required for actuation. Equipped with a moving clamping jaw and a swivelable console jaw. The console jaws define the height of the clamping position of the inserted workpiece.

CUSTOMER BENEFITS

- Rational machining in one set-up
- Fully automated work sequence of swivel positions while the machine is running
- High workpiece precision with regard to the crossing axes, since there is no reclamping
- Long service life thanks to sturdy construction



KSFZ indexing chuck

APPLICATION

For workpieces, such as forgings and castings, where a large diameter tolerance is to be compensated during clamping.

TYPE AND FUNCTION

Force-actuated indexing chuck.

CUSTOMER BENEFITS

- Centrally clamping - raw part tolerances are compensated
- Maximum productivity thanks to rational machining option in one set-up
- High workpiece precision, since no reclamping

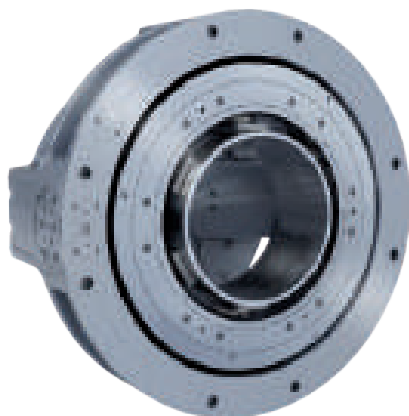

HSFZ ring indexing chuck

APPLICATION

Optimally suited for machining couplings from 2-3/8" to 20".

TYPE AND FUNCTION

Hydraulically actuated ring indexing chuck. 3-jaws centrally and 3-jaws compensating clamping.

CUSTOMER BENEFITS

- No deformation of the workpiece thanks to clamping inserts with several clamping points
- Maximum productivity thanks to rational machining option in one set-up
- High repeat positioning accuracy for maximum precision requirements

Quick-action clamping device change system

For quickly changing the clamping device

- ⊕ Easy clamping device change taking all the safety features of modern clamping technology into account
- ⊕ Use of nearly any clamping mandrels, face drivers or power chucks - they must only have the same connections - on the basic adapter, with shortest time required

Construction:

Similar to the automatic / semi-automatic clamping device change system, on the manual change system, too, an increasing number of variants can be produced in decreasing batch sizes more cost-effectively. A standard clamping cylinder without additional devices is sufficient for quickly changing the clamping device.

Particularly clamping mandrels, which often require a change in the clamping mandrel size due to its design, but also clamping systems such as face drivers or power chucks, can be quickly and safely interchanged among each other.

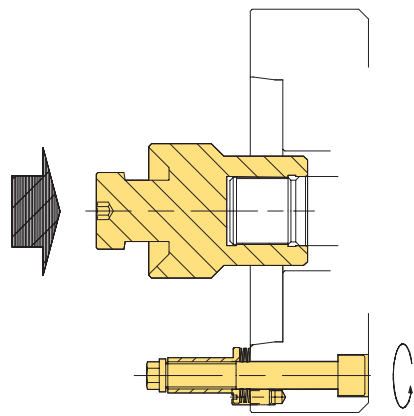
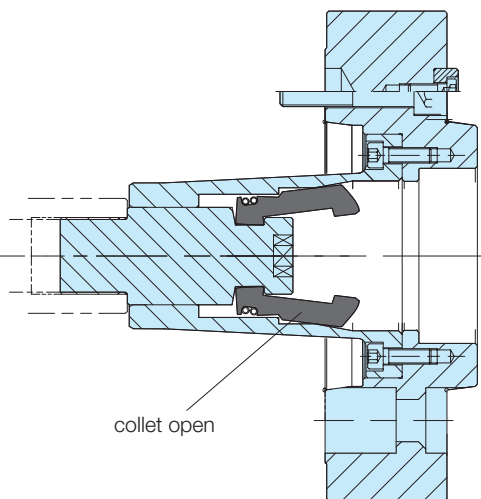
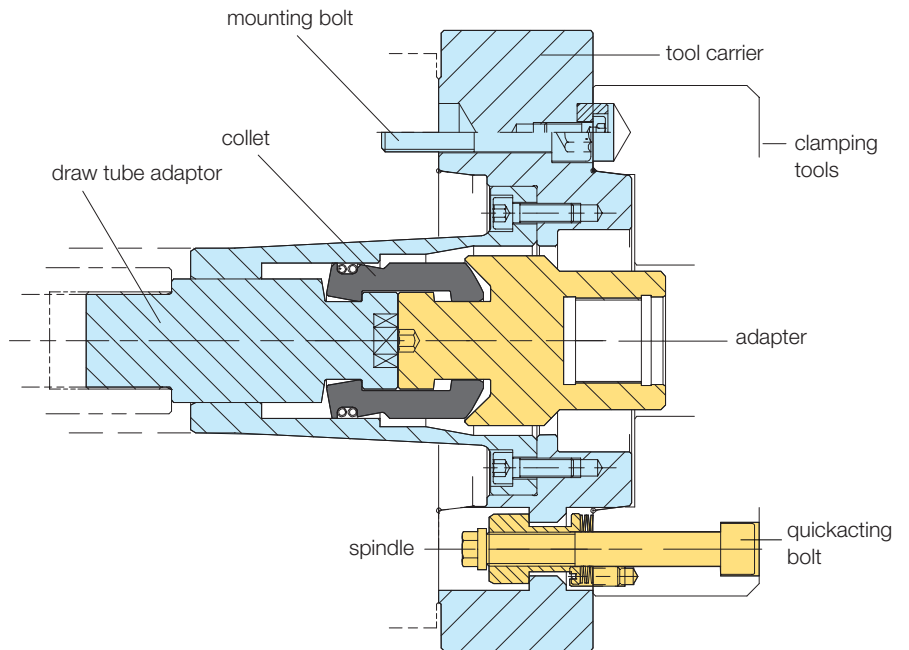

Quick-acting bolt backed off 1/2 turn

Changing the clamping device:

- ⊕ Move clamping cylinder to the front position
- ⊕ Loosen the quick-action clamping screw by 1/2 turn
- ⊕ Lift up the clamping device

Quick-action clamping device change system

Quick-action clamping device change system

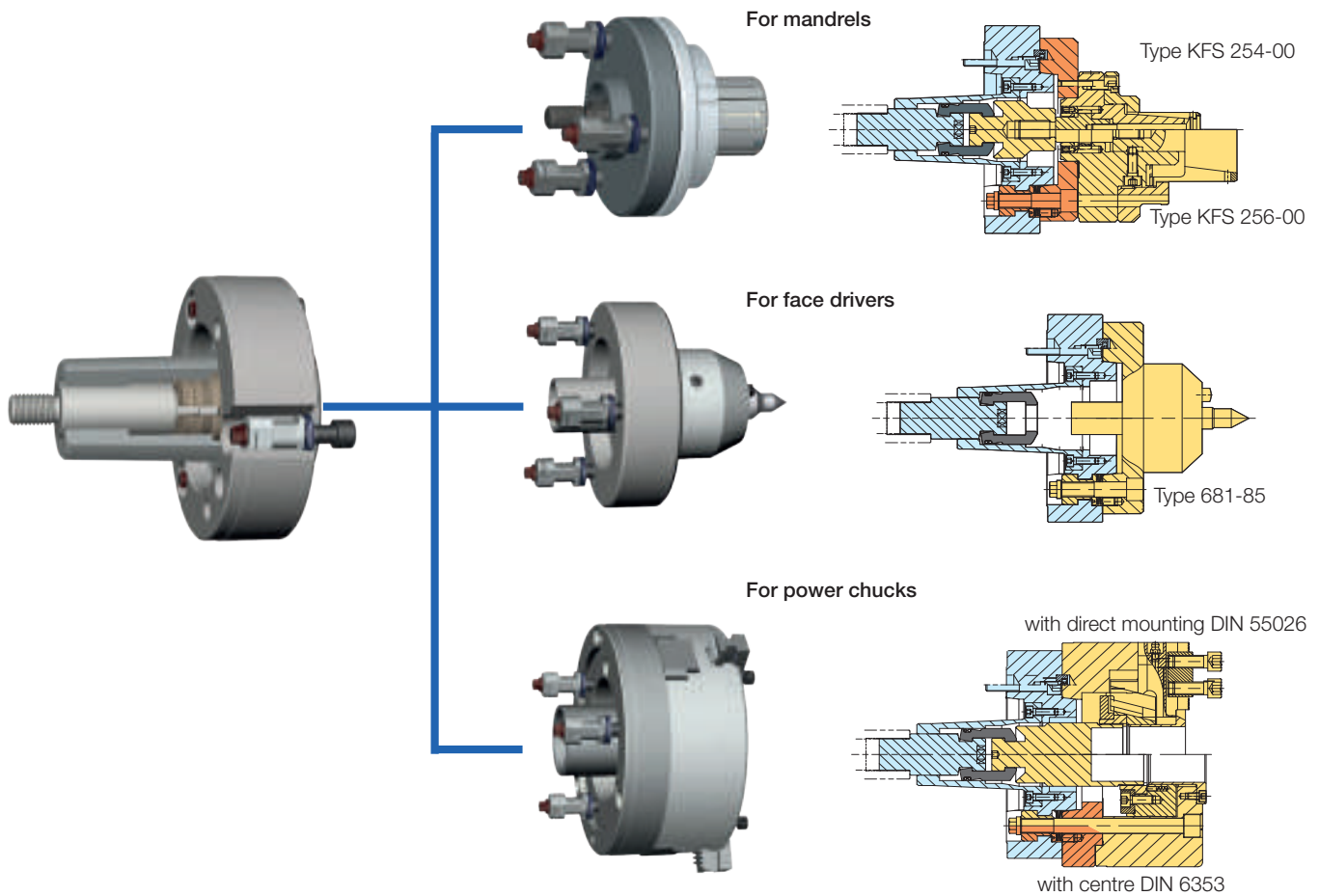

Technical features:

- ⊕ Exact take-up and positioning of the clamping device using short taper mount
- ⊕ Change precision within 0.005 mm
- ⊕ Change time approx. 30 seconds
- ⊕ Easy handling of the change operation
- ⊕ Locking the clamping device with 3 bayonet nuts and a collet chuck as intermediate piece for draw connection
- ⊕ Rotary lock of bayonet nut
- ⊕ High clamping precision
- ⊕ Clamping cylinders without additional devices
- ⊕ Stroke control on clamping cylinder
- ⊕ Central lubrication and/or air sensing possible
- ⊕ The manual quick-action clamping device change systems RMS, in combination with the RÖHM safety cylinders SZS, OVS, LHS-L, LVS, EHS and EVS, meet the guidelines of the Employer's Liability Insurance Association

Function:

A basic adapter is fastened to a turning spindle, in which a collet chuck is integrated for force transfer. The actual clamping device is adjusted on this basic adapter with quick-action clamping screws by a half turn of the wrench and then tightened. The collet chuck and clamping device are actuated via a safety clamping cylinder mounted to the end of the spindle without additional devices.

Function description:

The basic adapter with built-in collet chuck and draw piece with draw tube connection is screwed onto the spindle with 3 fastening screws. Through the positioning of the adapter of the respective clamping device (e.g. clamping mandrel, face driver, power chuck), the collet chuck is closed, thereby establishing the connection between the draw bar and actuating element (e.g. piston). The clamping device is fastened manually via 3 quick-action clamping screws by turning the wrench 1/2 turn each. The rotary lock of the bayonet nut is secured by a cylinder pin system. This guarantees equivalent fastening as compared to conventional fastening types. The clamping device is dismantled in the opposite order.

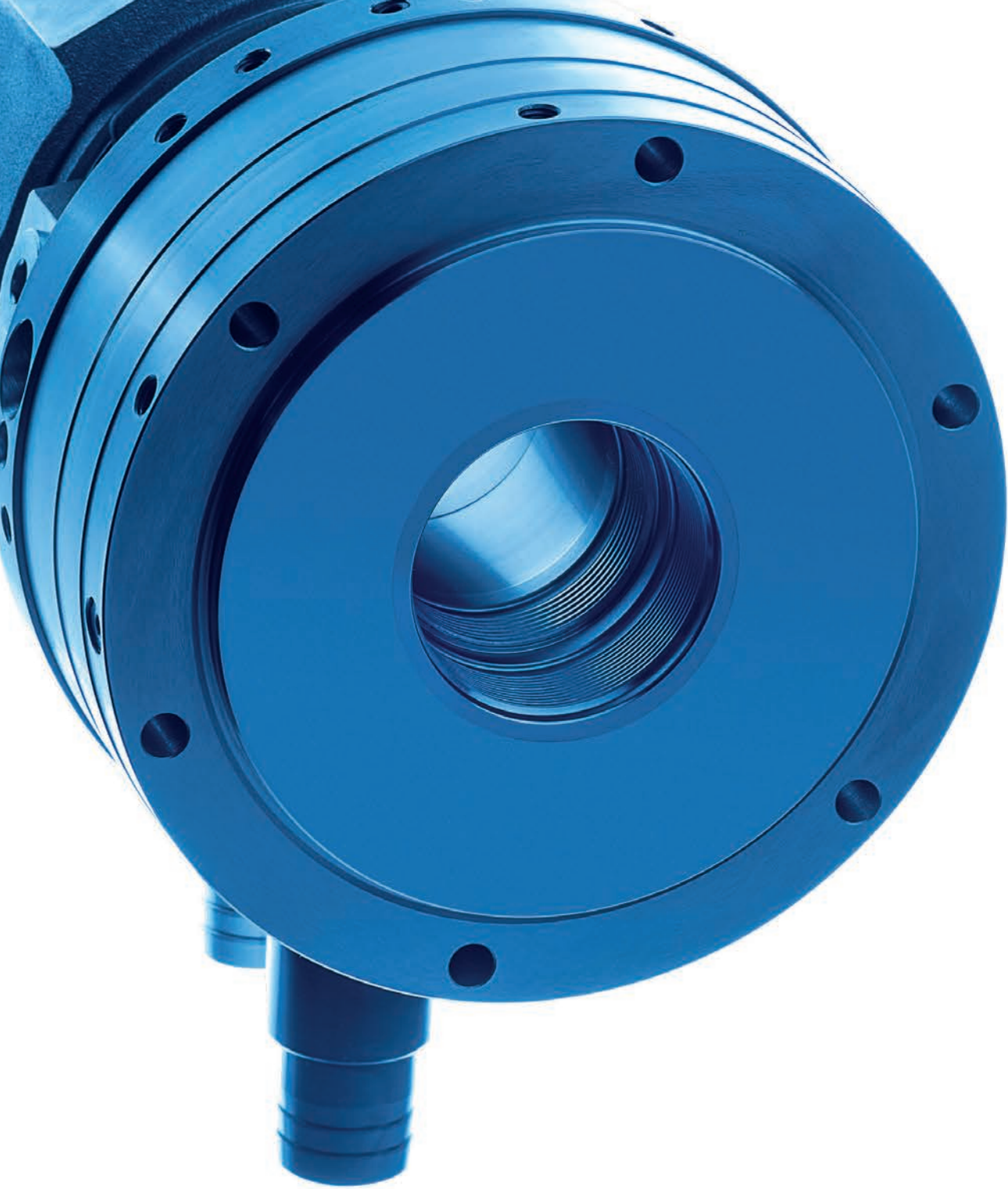

FOR EVERY APPLICATION

In order to be able to satisfy every application, RÖHM has hydraulically as well as pneumatically actuated cylinders with through-hole in their product range.



hydraulic operated



pneumatically operated

CYLINDERS WITH THROUGH-HOLE

RÖHM clamping cylinders with through-hole are optimally suited for machining different bar material thanks to their large through-hole. The short design and low weight of the clamping cylinders protect the machine spindle and the safety device ensures operational safety, even if the power fails during spindle rotation.

ADVANTAGES AT A GLANCE

- ⊕ Safe actuation of power chucks and collet chucks for hollow clamping
- ⊕ Versatile applications thanks to oil and air actuator media
- ⊕ Flexible use thanks to large strokes and forces

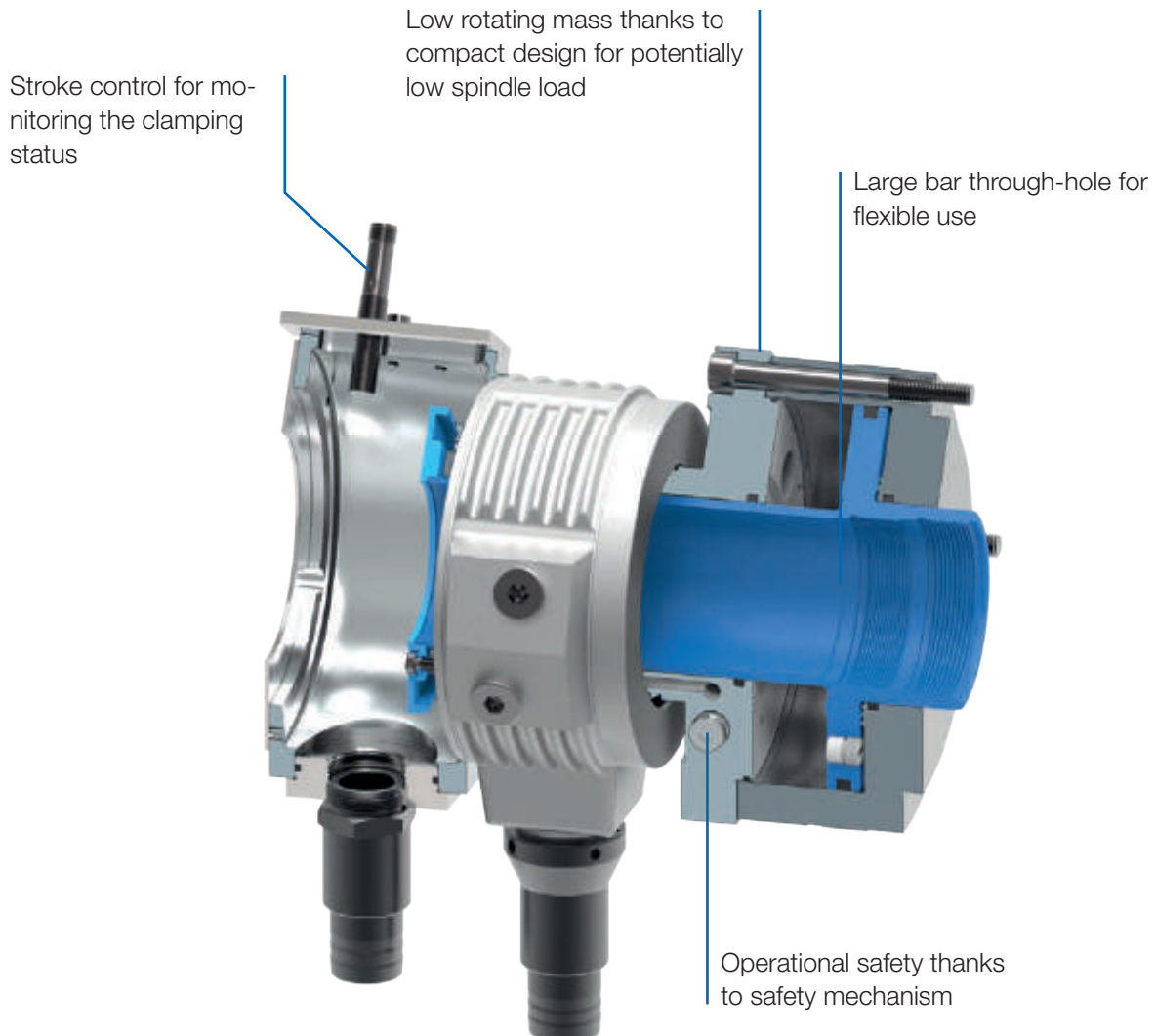

SZS



APPLICATION

Hydraulic actuation of power chucks/collet chucks with through-hole.

TYPE

Hollow clamping cylinders for actuation pressures of 8-45 bar.

CUSTOMER BENEFITS

- ⊕ Short design and low weight ensure small machine spindle load and also allow high speeds
- ⊕ Thanks to the large through-hole, optimally suited for machining bar material
- ⊕ Operational safety thanks to safety mechanism, guaranteed even if there is a pressure drop during spindle rotation

TECHNICAL FEATURES

- Stroke control by means of inductive proximity system or linear path measuring system F90 (stroke control system not included in the scope of delivery)
- Overpressure safeguard
- Coolant collector
- Fastening from the rear with through bolts
- For its actuation, we recommend hydraulic oil H-LP 32, DIN 51525 (32 centistokes at 40° Celsius)
- Insert a filter unit (10 µm) between the pump and control valve
- Can also be actuated during rotation
- Hollow clamping cylinders can usually only be used for horizontal machining axes

Note:

ROHM clamping cylinders meet the testing requirements of the Employer's Liability Insurance Association thanks to their safety system and stroke check.

SZS = clamping, cylinder, with safety mechanism

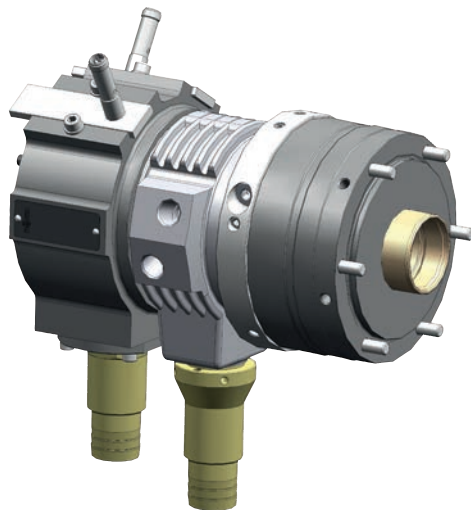

Standard:

Prepared for inductive proximity system

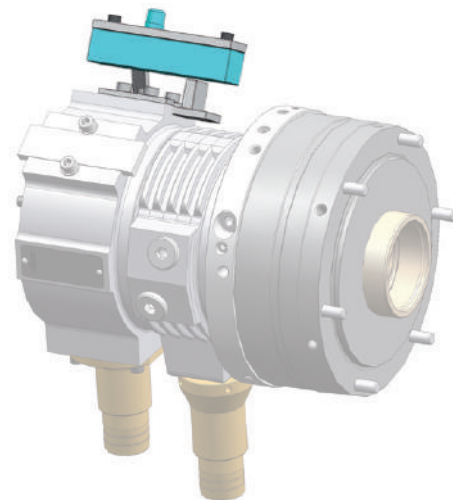

Optional stroke monitoring with F 90:

High resolution, minimal temperature drift, contactless, teachable, inductive effect principle

Oil-operated actuating cylinders with through-hole

SZS up to 45 bar, short design

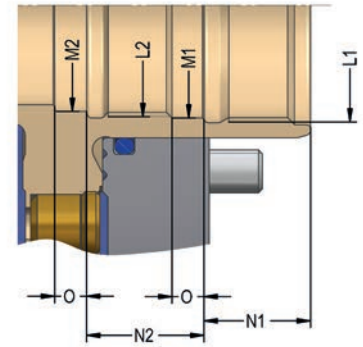
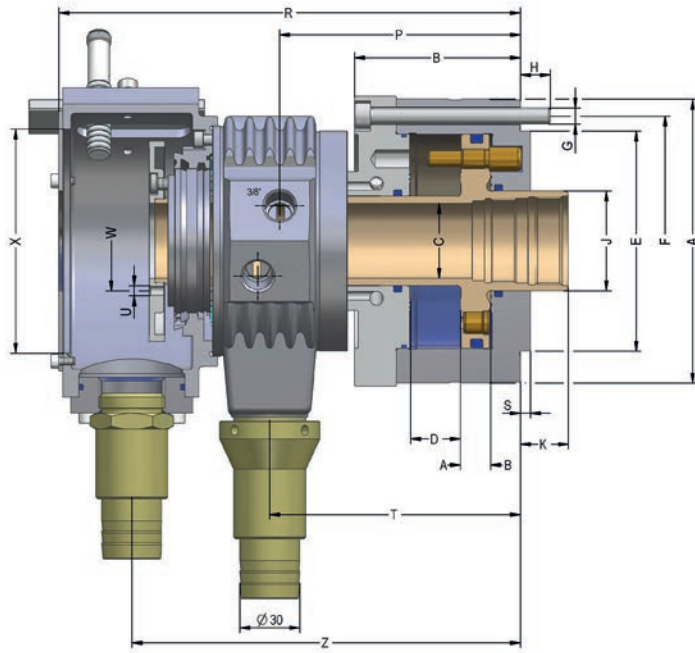

C 15
Oil operated cylinders **SZS**, basic model up to 45 bar, short design for high speeds

Item No.	432765	432766	432767	432768	432769 ▲	432770 ▲	435766 ▲	433217 ▲
Size	46/103	52/130	67/150	77/170	86/200	95/225	110/250	127/325
A mm	162	182	197	212	228	245	264	295
B mm	83	83	94	94	104	104	104	127
C mm	46,5	52,5	67,5	77	86,5	95,5	110,5	127,5
Stroke D mm	25	25	30	30	35	35	35	40
Eh6 mm	130	140	160	160	180	210	210	250
F mm	147	165	180	195	210	227	240	270
G	6xM8	6xM8	6xM10	6xM10	6xM10	6xM10	6xM10	6xM12
H mm	15	15	15	15	15	15	16	20
J mm	61	70	85	95	105	115	130	145
K max.	22	22	25	25	31	31	31	44
K min.	-3	-3	-5	-5	-4	-4	-4	4
L1	M55x2	M60x1,5	M75x2	M85x2	M95x2	M105x2	M120x2	M135x2
L2	M50x1,5	M55x2	M72x1,5	M80x2	M90x2	M100x2	M115x2	-
M1 mm	52,5	57,5	72,5	82	92	102,5	117,5	132
M2 mm	47	52,5	69	77	87	97	112	-
N1 mm	25	25	25	25	32	32	32	30
N2 mm	25	28	28	28	30	30	30	-
O mm	6	6	6	6	6	6	6	6
P mm	120,5	120,5	138,5	138,5	155	159	166,3	196
R mm	231	231	269	269	292	302	321	355
S mm	5	5	8	8	8	8	8	5
T mm	125,75	125,75	142,75	142,75	159,25	163,25	171,5	201,5
U	2xM6	2xM6	2xM6	2xM6	2xM6	2xM6	4xM6	2xM6
W mm	68	76	91	91	116	120	135	150
X mm	122	122	135	145	167	177	116	131
Z mm	195,5	195,5	225	226	249	259	275	307
Piston area A cm ²	109,8	142,4	164,5	184	212,6	243,5	267	337
Piston area B cm ²	103,5	131	152	170	197	226,2	247,4	325,7
Eff. draw bar pull (F=45 bar) kN	46	58	68	76	88	100	110	145
Max. admissible speed min ⁻¹	7000	6300	5500	5000	4500	4000	3500	3200
Oil leakage rate (30 bar 50° C - n max.) l/min	3	3,5	4	4,5	5	5	5	6
Moment of inertia J kgm ²	0,03	0,045	0,07	0,13	0,17	0,3	0,35	0,58
Weight approx. kg	16	18	22	30	35	38	48	66

Oil-operated cylinders with through-hole

LHS-L

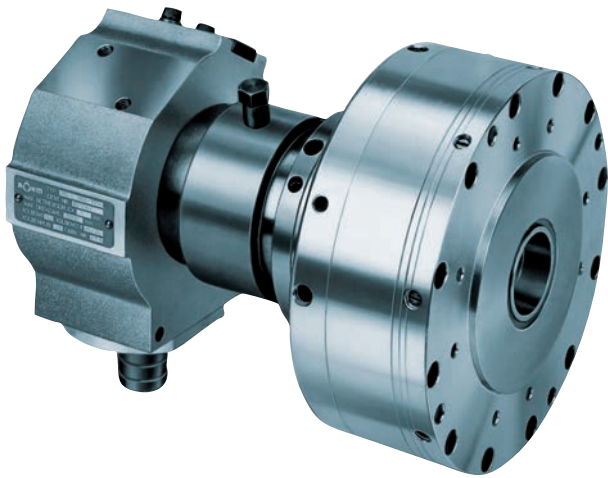

APPLICATION

Pneumatic actuation of power chucks/collet chucks with through-hole.

TYPE

Hollow clamping cylinders for actuation pressures from 1.5-8 bar.

CUSTOMER BENEFITS

- ⊕ Short design and low weight ensure small machine spindle load and also allow high speeds
- ⊕ Thanks to the large through-hole, optimally suited for machining bar material
- ⊕ Operational safety thanks to safety mechanism, guaranteed even if there is a pressure drop during spindle rotation

TECHNICAL FEATURES

- Stroke control via inductive proximity switches (not included in the scope of delivery)
- Coolant collector
- Can also be actuated during rotation

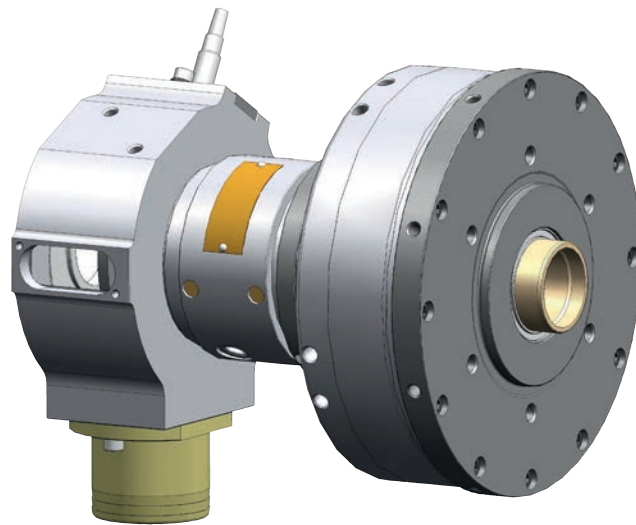
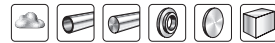

Air-operated cylinders with through-hole

Accessories:

Connection for supply and drain hoses

Special accessories:

2 inductive proximity switches piece/item no. 381551 (opener)
or 2 inductive proximity switches piece/item no. 202759 (closer)

With tandem piston on request.

LHS-L

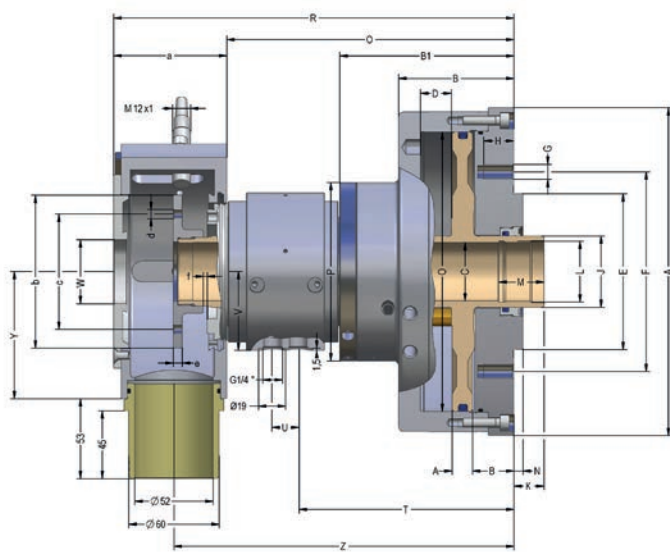

stroke control size 42 and 62

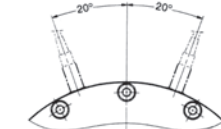
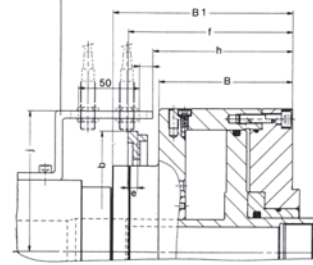

with tandem piston on request

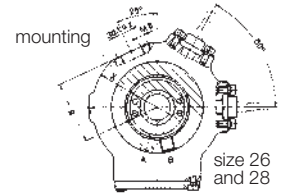

C 15

 Air actuating cylinders with through-hole **LHS-L with safety valve**

The coolant collection shell (sizes 26 and 38) must be held centrally by a bracket on the machine

Item No.	417310 ▲	417311 ▲	417312 ▲
Size	26/190	38/251	42/289
A mm	187	215	235
B mm	76	78	109,7
B1 mm	110	110	147,5
C mm	26,2	38,2	42
Stroke D mm	20	20	32
E-0,01 mm	70	103	103
F mm	105	132	145
G	6 x M 8	6 x M 10	8 x M 8
H mm	15	20	20
J mm	38	50	57
K max.	20	20	20
K min.	0	0	-12
L	M 32 x 1,25	M 44 x 1,5	M 52 x 1,5
M mm	25	30	30
N mm	5	6	6
O mm	160	185	200
P mm	106	118	140
Q mm	197	198	263,7
R mm	275	273	337,7
S mm	210	211	283,5
T mm	141	140	188
U mm	23	23	28,5
V mm	46	52	60
W mm	42	42	51
X mm	130	151	151
Y mm	73,5	84	84
Z mm	233,5	233	297,7
a mm	78	75	74
b mm	77	101	197
c mm	61	76	-
d	4 x M 6	4 x M 6	-
e mm	7,5	7,5	8
f max.	22,5	22,5	135
f min.	2,5	2,5	167
g mm	62	72	-
h mm	-	-	114,7
j mm	-	-	115
Piston area A cm ²	189,7	249,1	288,6
Piston area B cm ²	190,9	251,4	291,3
Eff. draw bar pull (F=6 bar) kN	10,47	13,75	15,90
Max. admissible speed min ⁻¹	6500	6500	4000
Volume for full double stroke l	0,762	1	1,9
Moment of inertia J kgm ²	0,03	0,06	0,102
Weight approx. kg	11,8	16	25,5

When working with high and low pressure, the release of the safety valve is guaranteed for clamping pressure: unclamping pressure ≤ 2:1

Special solutions - on request

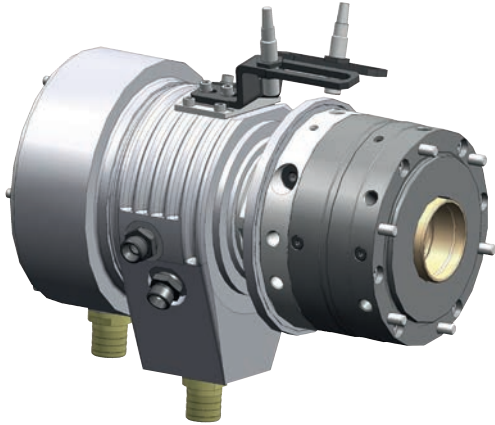

SZS (80 bar) Hollow clamping cylinder

APPLICATION

For the hydraulic actuation of power chucks/collet chucks with through-hole.

TYPE

Hollow clamping cylinders for actuation pressures up to 80 bar.

CUSTOMER BENEFITS

- ⌚ Stroke control outside of the coolant collection bowl
- ⌚ Operational safety thanks to safety valve, guaranteed even if there is a pressure drop during spindle rotation
- ⌚ Low mass moment of inertia and required installation space thanks to reduced external diameter
- ⌚ Flexible application: Low draw forces thanks to reduced piston surface, and nevertheless maximum draw forces thanks to high maximum actuation pressure

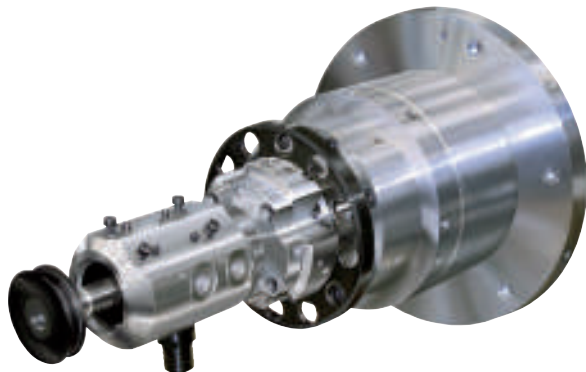

OVUSHH Double piston cylinder

APPLICATION

For hydraulic actuating of power chucks with additional functions (ejector, retractable center points, etc.).

TYPE

With 4-way oil supply.

CUSTOMER BENEFITS

- ⌚ Different strokes, piston surfaces and arbitrary safety requirements can be realized thanks to modular system
- ⌚ Feed-through of another medium (coolant, oil, air, etc.) through the cylinder axis by installing an additional rotary feed-through



Notes



FOR EVERY APPLICATION

In order to be able to satisfy every application, RÖHM has hydraulically as well as pneumatically actuated cylinders without through-hole in their product range.



hydraulic operated



pneumatically operated

CYLINDER WITHOUT THROUGH-HOLE

RÖHM clamping cylinders without through-hole are optimally suited for actuating power chucks or special clamping devices for full or partial hollow clamping. Thanks to the possibility of a horizontal or vertical installation position, the clamping cylinders can be used flexibly and the safety mechanism guarantees operational safety, even if the power fails during spindle rotation.

ADVANTAGES AT A GLANCE

- ⊕ Safe actuation of power chucks or special clamping devices for full or partial hollow clamping
- ⊕ Versatile applications thanks to oil and air actuator media
- ⊕ Flexible use thanks to large strokes and forces

Stroke control for monitoring the clamping status

Low rotating mass thanks to compact design for potentially low spindle load

Safety mechanism to guarantee operational safety

Prepared for media feed-through via optional rotary feed-through (except for LVS)

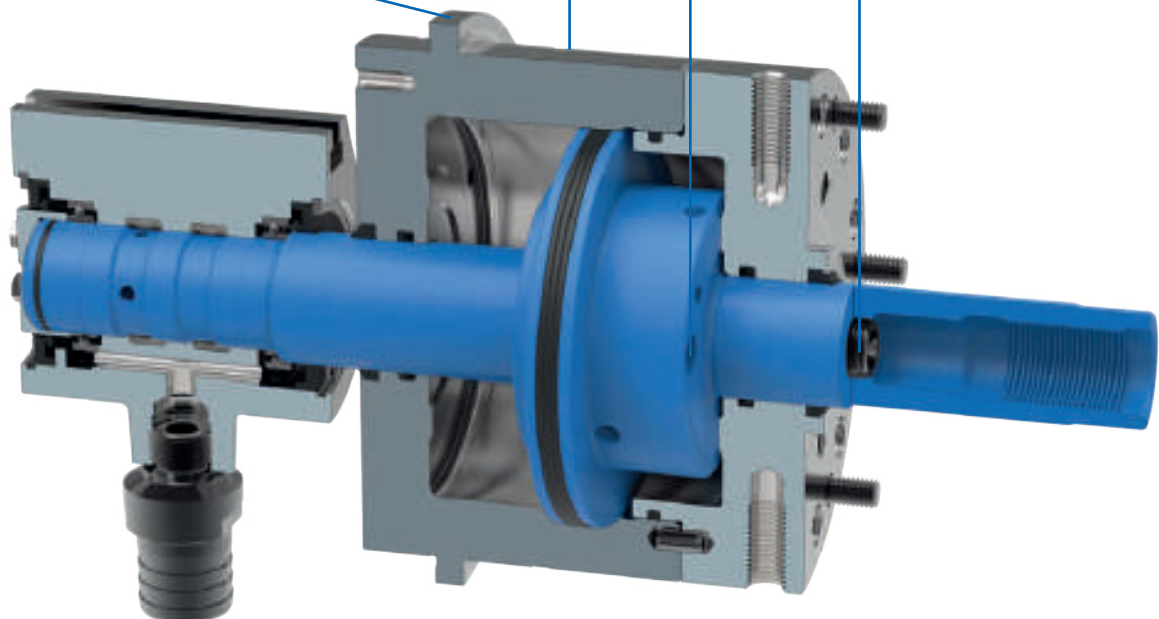

Cylinder without through-hole



APPLICATION

Hydraulic actuation of power chucks (full or partial hollow clamping).

TYPE

Clamping cylinders without through-hole for actuation pressures from 8-80 bar.

CUSTOMER BENEFITS

- ⊕ Compact design and low mass moment of inertia for low machine spindle load
- ⊕ Operational safety thanks to safety mechanism, guaranteed even if there is a pressure drop during spindle rotation
- ⊕ Flexible use thanks to possible horizontal or vertical installation position

TECHNICAL FEATURES

- Stroke control by means of inductive proximity system or linear path measuring system F90 (stroke control system not included in the scope of delivery)
- Through-hole for media feed-through
- For its actuation, we recommend hydraulic oil H-LP 32, DIN 51525 (32 centistokes at 40° Celsius)
- Insert a filter unit (10 μm) between the pump and control valve

OVS = oil-operated, without through-hole, with safety mechanism

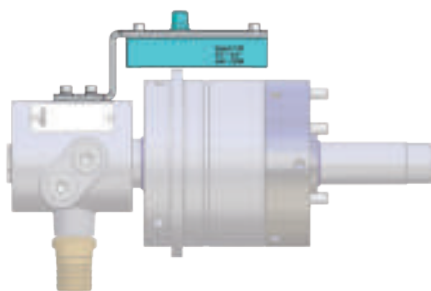

Stroke control with monitoring system F 90:

- High resolution and accuracy
- Minimal temperature drift
- Contactless
- Teaching mode
- Inductive principle of operation

With high and low pressure chucking the change-over of the safety valve is guaranteed when:
 chucking pressure : releasing pressure =< 5,5 : 1 (Size 85 - 130)
 chucking pressure : releasing pressure =< 3,8 : 1 (Size 150 - 200)

OVS

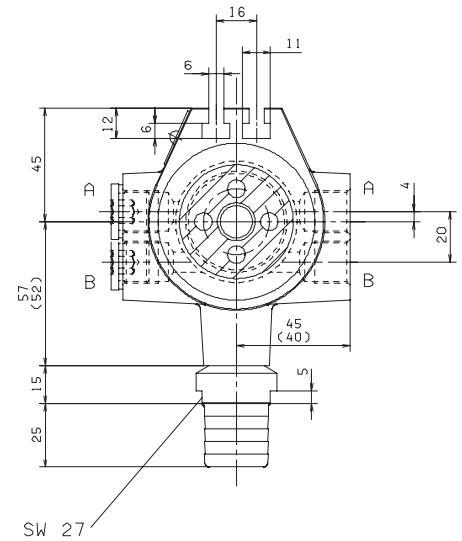
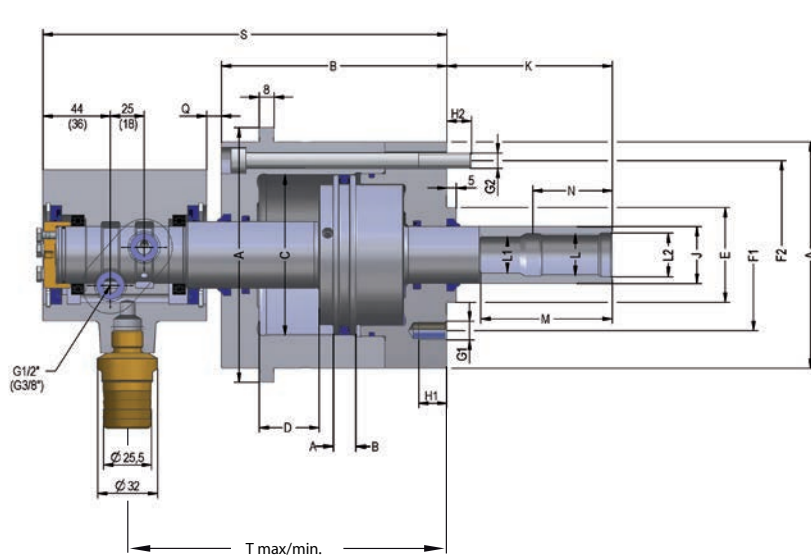

C 15
Oil-operated actuating cylinders without through-hole **OVS, basic model, with safety device, up to 80 bar - Steel design** for high speed, fastening from the rear, central through-hole

Item No.	438261	438262	438263	438264	438265
Size	85	105	130	150	200
Design	steel	steel	steel	steel	steel
A mm	120	140	165	193	245
A1 mm	135	155	180	208	260
B mm	120	120	120	147	164
C mm	85	105	130	150	200
Stroke D mm	32	32	32	45	50
Eh6 mm	50	50	80	95	125
F1 mm	80	80	105	145	170
F2 mm	100	120	145	170	220
G1	M10 (3x120°)	M10 (4x90°)	M12 (4x90°)	M16 (4x90°)	M16 (6x60°)
G2	M8 (6x60°)	M8 (6x60°)	M8 (8x45°)	M10 (8x45°)	M12 (8x45°)
H1 mm	15	15	18	24	29
H2 mm	13	13	13	14	19
J mm	30	32	42	50	70
K max.	88	88	82	98	108
K min.	56	56	50	53	58
L mm	M 22 x 1,5	M 22 x 1,5	M 30 x 2	M 36 x 2	M 48 x 2
L1 mm	19	19	26	30	42
L2 mm	23	23	32	38	50
M mm	70	70	88	105	125
Min. reach of draw bar N mm	43	43	65	78	90
Q max.	40	40	40	53	58
Q min.	8	8	8	8	8
S max.	252	247	247	307	329
S min.	220	215	215	262	279
T max.	202	202	202	250	272
T min.	170	170	170	205	222
Piston area A cm ²	47,1	77	116,8	160,8	298,2
Piston area B cm ²	49,7	78,6	118,9	157,1	275,7
Eff. draw bar pull (F=60 bar) kN	29,50	47	71,3	94	165,4
Max. admissible speed min ⁻¹	8000	8000	5000	5500	4500
Volume for full double stroke l	0,31	0,5	0,775	1,43	2,87
Moment of inertia J kgm ²	0,018	0,03	0,066	0,142	0,36
Weight approx. kg	10	12,7	17,7	31,4	49
Suitable connecting flange for Duoflow Rotating Unions	1022186	1022186	1022187	1022187	1022187

Oil-operated cylinders without through-hole

Stroke Monitors OVS

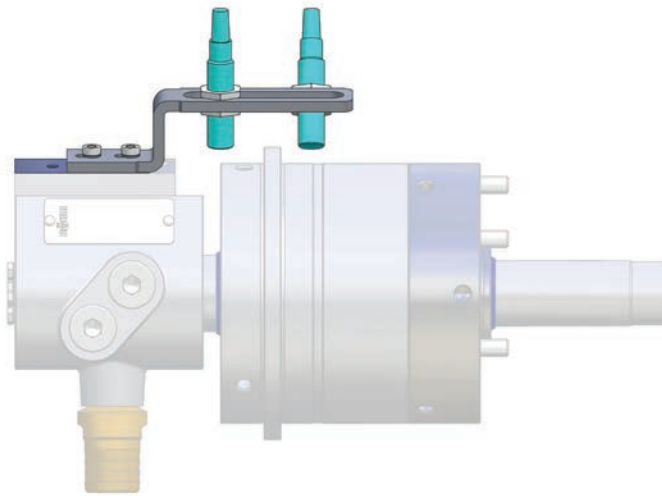

C 15

OVS-stroke monitoring by inductive proximity switches (Limit switch not included in the scope of delivery)

Item no.	Size
1159712	OVS 85
1159713	OVS 105
1159714	OVS 130
1159715	OVS 150
1159716	OVS 200

Order cylinder separately
External rotary feed-throughs fitting Deublin/Rotoflux

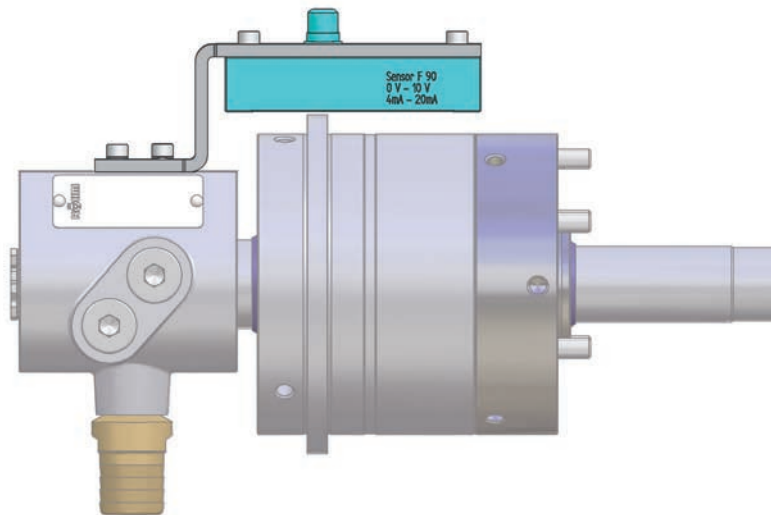

C 15

OVS-stroke monitoring linear, inductive F90 (F90 system included)

Item no.	Size
1159707	OVS 85
1159708	OVS 105
1159709	OVS 130
1159710	OVS 150
1159711	OVS 200

Order cylinder separately
External rotary feed-throughs fitting Deublin/Rotoflux
Linear stroke monitoring sensors with IO-Link on request

Oil-operated cylinders
without through-hole

Accessories

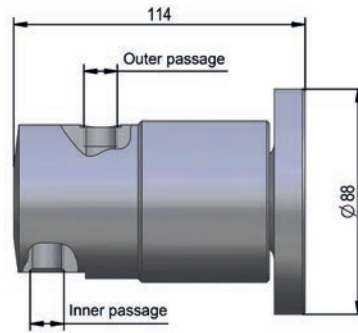

C 15
2-Through-hole rotating unions

Item no.	Inner passage			Outer passage		
	Connection	Media	Max. Pressure	Connection	Media	Max. Pressure
1118078	1/4	Oil	100	1/4	Oil	30
1118079	1/4	Oil	70	1/4	Air	10
1118080	1/4	Coolant	70	1/4	Air	10
1118081	3/8	Air	10	1/8	Air	10
1118082	1/4	Air	10	1/4	Oil	40
1118083	1/4	Air	10	1/4	Coolant	40

Optional: 1-Through-hole Rotating Union for OVS Size 85-105 Item No.: 10003958
 Optional: 1-Through-hole Rotating Union for OVS Size 130-150 Item No.: 10003959
 Optional: 1-Through-hole Rotating Union for OVS Size 200 Item No.: 611172
 Connecting flange complete for 2-passage rotating union size 85-105 Item no.: 1022186
 Connecting flange complete for 2-passage rotating union size 130-200 Item No.: 1022187



APPLICATION

Pneumatic actuation of power chucks or special clamping devices (full or partial hollow clamping).

TYPE

Clamping cylinders without through-hole for actuation pressure 2-10 bar.

CUSTOMER BENEFITS

- ⊕ Operational safety thanks to standard safety mechanism, guaranteed even if there is a pressure drop during spindle rotation
- ⊕ Flexible use thanks to possible horizontal or vertical installation position

TECHNICAL FEATURES

- Stroke control by means of inductive proximity system or linear path measuring system F90, fastened on the machine side (stroke control system not included in the scope of delivery)
- The maximum permissible speed can be run in continuous operation (100% ED)
- Can also be actuated during rotation
- On request with central media feed-through

LVS = air-operated, without through-hole, with safety mechanism

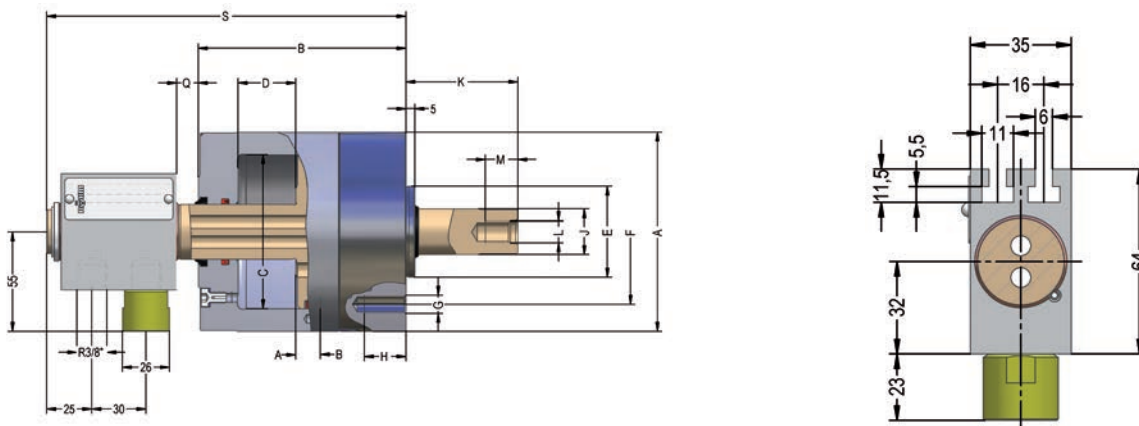

C 15
LVS Air actuating cylinders without through-hole with safety mechanism and stroke control

Item No.	096553	096554	096555	096556	096557	096558	096560 ▲
Size	85	105	130	150	200	250	350
A mm	110	130	155	180	240	287	387
B mm	115	115	117	128	125	125	148
C mm	85	105	130	150	200	250	350
Stroke D mm	32	32	32	32	32	32	45
Eh6 mm	50	50	80	95	95	125	125
F mm	80	80	105	145	145	170	170
G	3 x M 10	3 x M 10	3x M 12	4 x M 16	4 x M 16	6 x M 16	6 x M 16
H mm	23	23	27	35	35	35	35
J mm	25	25	25	25	35	35	35
K max.	62	88	79	74	87	87	82
K min.	30	56	47	42	55	55	37
L	M 12	M 12	M 16	M 16	M 24	M 24	M 24
M mm	18	18	24	24	36	36	36
Q max.	44	44	44	44	44	44	57
Q min.	12	12	12	12	12	12	12
S max.	231	231	233	244	241	241	277
S min.	199	199	201	212	209	209	232
Piston area A cm ²	49,7	79,5	125,7	169,6	307,1	483,8	955
Piston area B cm ²	51,8	81,7	127,8	171,8	304,5	481,5	952,5
Eff. draw bar pull (F=6 bar) kN	3	4,80	7,50	10	18	28,50	56,50
Max. admissible speed min ⁻¹	5000	5000	5000	5000	4500	4000	3200
Air consumption for full double stroke at 6 bar NL	2,8	4,6	6,5	7,5	12,5	18	50
Moment of inertia J kgm ²	0,007	0,009	0,03	0,06	0,09	0,10	0,45
Weight approx. kg	5,3	6,5	9	12,5	19,5	23	32,5

Air operated cylinders without through-hole



Notes

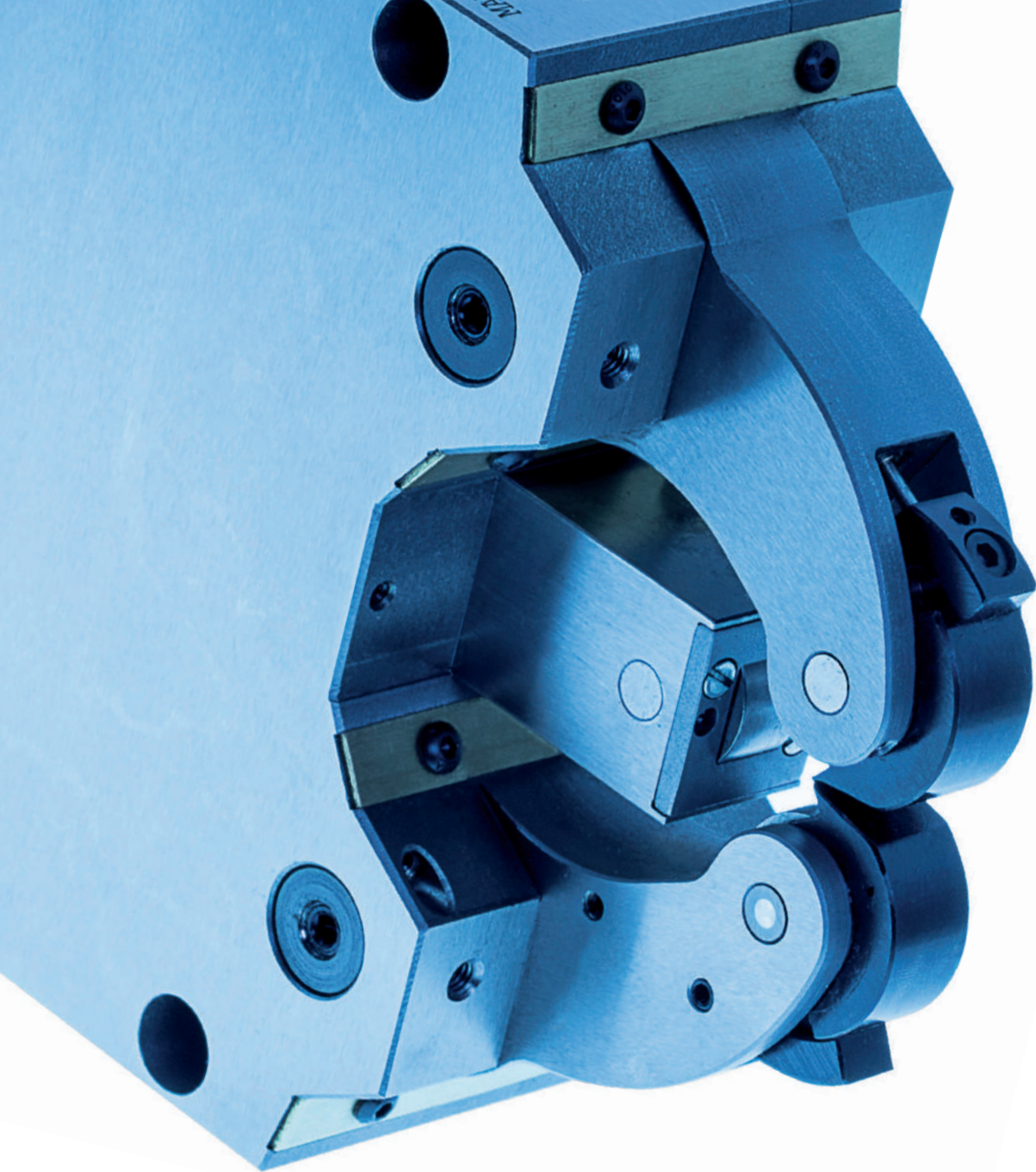

OPTIMAL COMPONENT SUPPORT

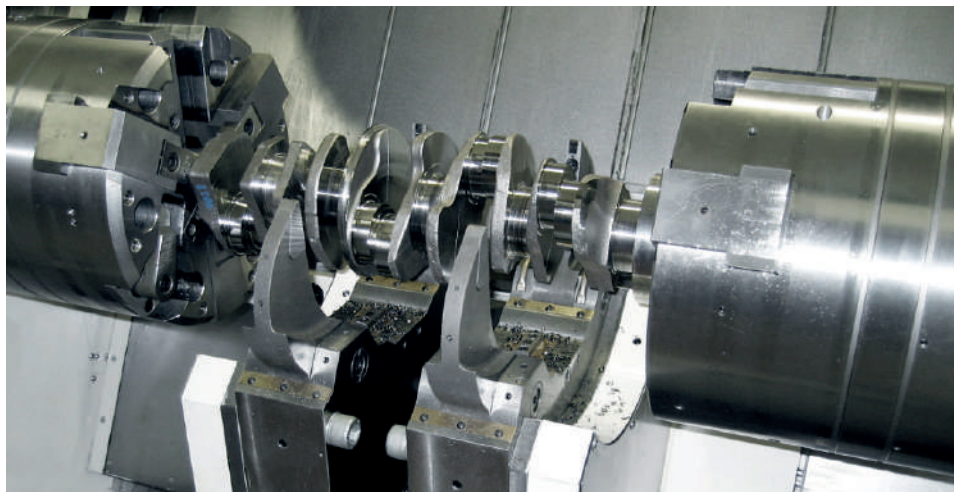

Optimal support of components for every application, e.g. crankshaft machining

SELF-CENTERING STEADY RESTS

With self-centering steady rests, RÖHM makes an important contribution toward the support of slender turned parts on lathes and meets all requirements for a large clamping range without change elements, a short and sturdy design, high centering precision and repeatability, as well as precision stability for clamping pressure changes and central lubrication.

ADVANTAGES AT A GLANCE

- ⊕ Support of components with extreme center precision and repeatability thanks to optimized cam lever system
- ⊕ Standardized equipped with central lubrication for use under difficult conditions and with high dirt accumulation
- ⊕ Large clamping range without change elements thanks to special curved geometry

Simple attachment of a safety valve and dosing valves for the central lubrication system to increase maintenance friendliness for SLZN or SLZN-B

Safety valve for guaranteeing operational safety in the event of a pressure drop (optionally for SLZ-047)

Hydraulic or pneumatic actuation possible

Central lubrication or manual lubrication possible, depending on the application

All versions available with and without chip protection

Depending on the application, round or cylindrical rollers available (except for SLZK)

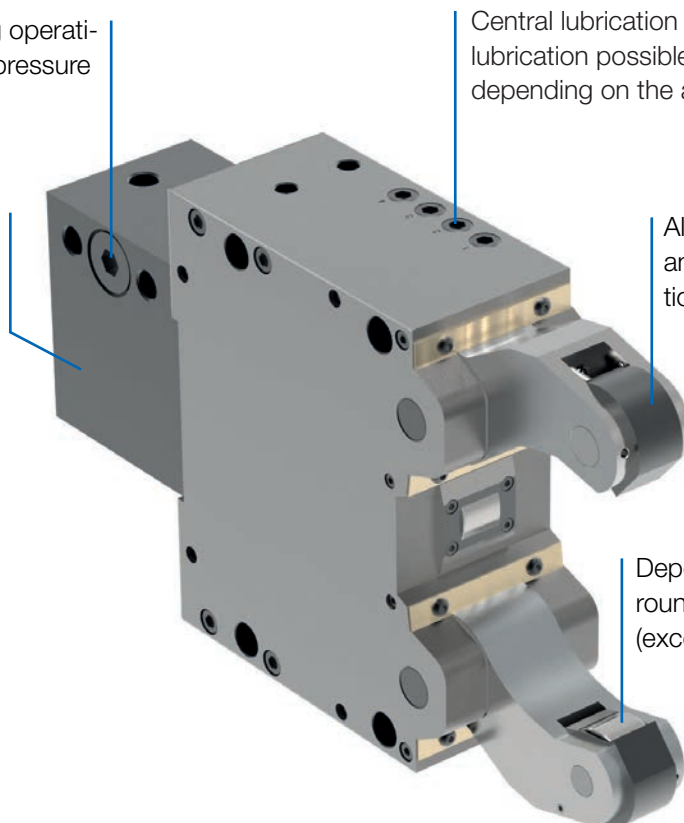

Function description

Different attachment options allow possible use for turning, facing, centering, drilling, internal machining, copy turning, etc., both as a stationary as well as a rotating steady rest in any angular position relative to the lathe tool.

Also in the case of a stationary steady rest, the shaft can be machined along the entire length since, on the one hand, the opening between the rollers leaves room for tools and on the other hand, the rollers reclamp self-centering. Here, 2 supporting steady rests are to be provided so that one of these can support the workpiece over the entire width of the roller.

The cylinder installed to actuate the steady rest can be selected for hydraulic or pneumatic actuation. The only difference is the size of the piston surfaces.

List of abbreviations

SP	=	Air purge connection
ZS	=	Central lubrication of the steady rest
HN	=	Check via steady rest proximity switch (not included in delivery) in the open position
HK	=	Stroke control rod
RZ	=	Rollers, cylindrical
RB	=	Rollers, convex

Standard configuration

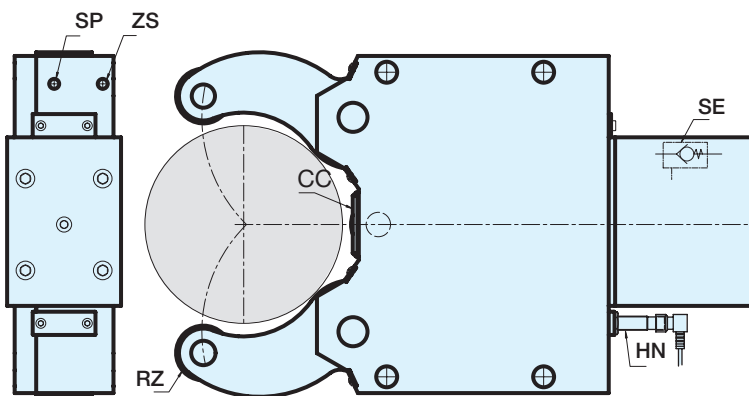

The standard steady rest is configured as follows:

- Cylindrical rollers
- Pressurization
- Central lubrication
- Axially extended cylinder with safety valve (except SLZ-047)
- Proximity switch component (open steady rest) for possible using of HN
- Device for manual lubrication via grease cup or oiler

Function description

Lubrication

Only one connection is required for the central lubrication system. The dosing units for the rollers are integrated in the steady rest body and ensure sufficient lubrication in the corresponding time interval.

Oil central lubrication (standard)

RÖHM steady rests are standard-equipped with a central lubrication system. The dosing valves required for lubrication are built into the steady rest body. Lubrication intervals (depending on load) 2-5 minutes at an operating pressure of 16-50 bar.

Manual lubrication (option)

Steady rest for moderate load and low dirt accumulation. Lubrication points and rollers are supplied with grease via grease nipples and grease gun. Lubrication intervals every 4 to 8 operating hours, depending on application.

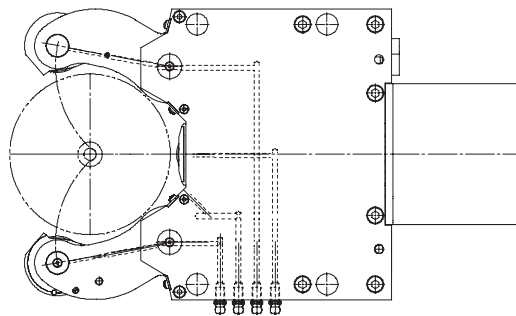
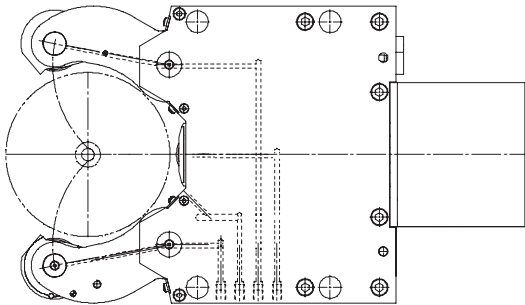

Rollers

The rollers are supported by roller bearings radially and axially. In the standard version, these are cylindrical or convex. In the case of conical workpieces and for follower rests arrangement, convex rollers are to be used. Here, too, customized designs on request supplement the product range.

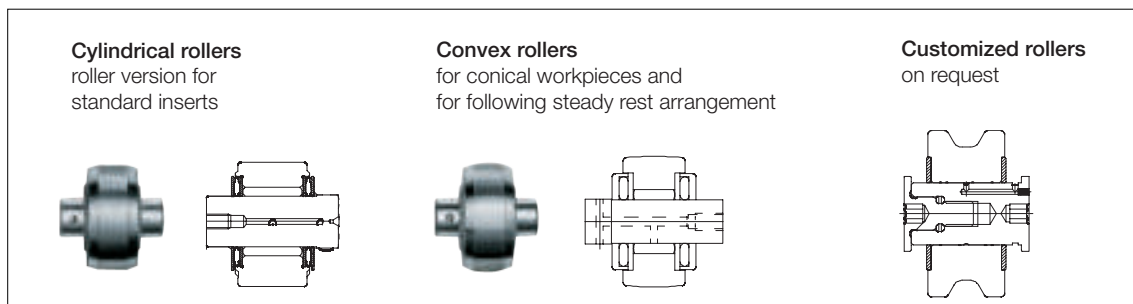

Standard accessories of SLZN series

Clamping arm control system SLZ-HN

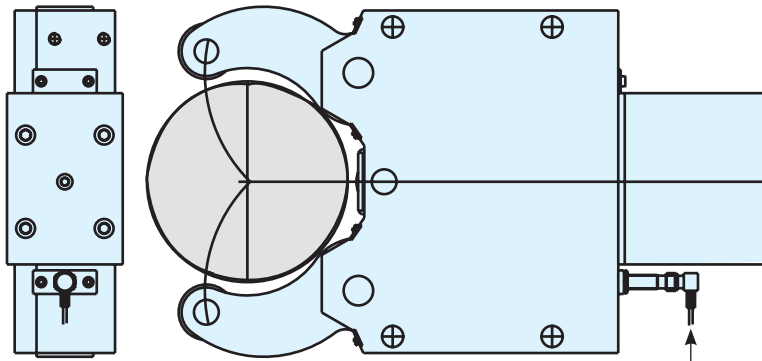

There is the option of attaching a sensor (proximity switch) to the steady rests as standard, which measures the position of the opened steady rest. This option is not available for the steady rest of type SLZ-047. The proximity switch is not included in the delivery of the steady rest.

Not included in the scope of delivery

Control system of the clamping arms SLZ-HK

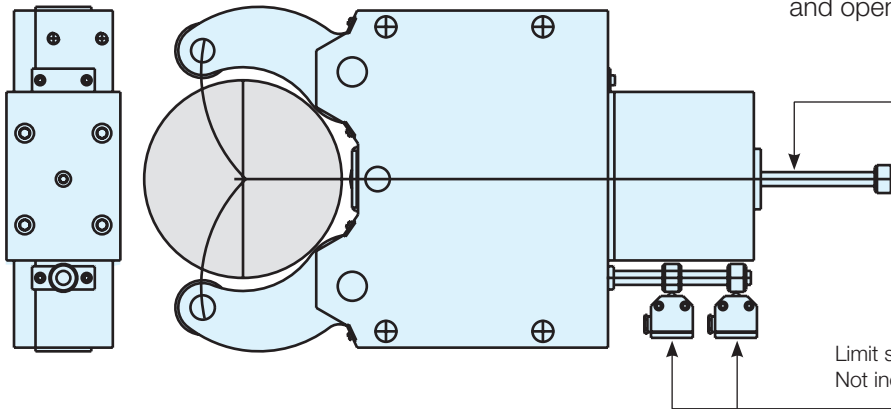

All steady rests of type SLZN and SLZNB can be equipped with holders and rods or only with rods, in order to be able to control the clamping position and open position using limit switches.

Position only for SLZ-047

Limit switches/path measuring system
Not included in the scope of delivery

Standard accessories of SLZN series

Safety valve SE

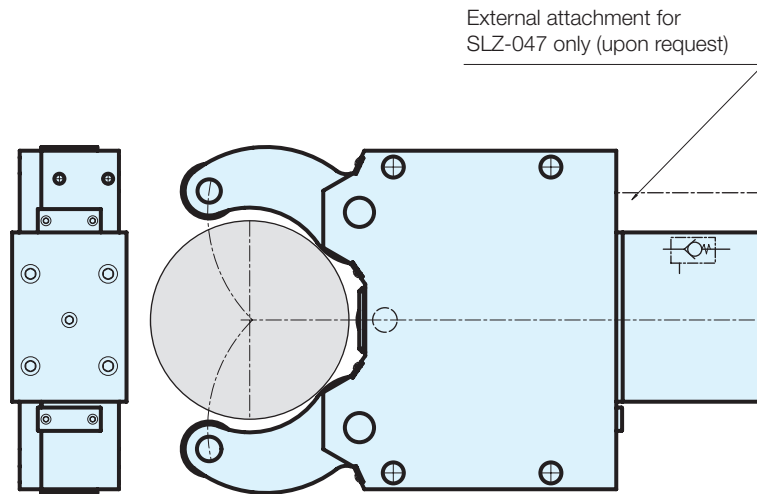

All standard steady rests are equipped with a safety valve integrated in the cylinder. If the clamping pressure in the cylinder should be interrupted, the valve prevents the steady rest from opening. With moving applications, the safety valve isn't necessary. We would be happy to help you if need be. This device is available as an option for the SLZ-047 series.

Pressurization

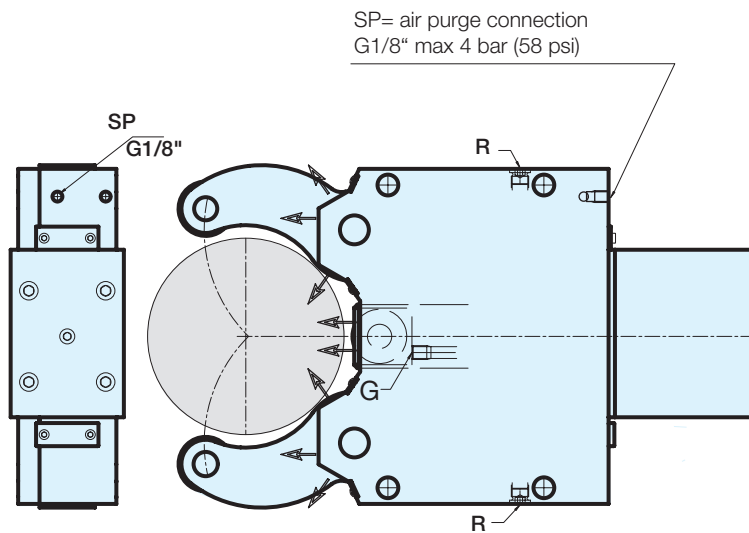

All RÖHM steady rests have a G 1/8" air purge connection; This system protects the body of the steady rest from chip and dust penetration. When the steady rest is completely open, the air consumption is automatically reduced, but not completely interrupted to prevent unnecessary air consumption. The system includes the cleaning of the middle roller bearings. To activate this option, the screw „G“, which is located in the housing floor, must be removed. The pressure can vary between a minimum of 2 bar and maximum of 4 bar (58 psi). The steady rest can also be used without the air purge. Drain holes are on the top and bottom part of the steady rest housing. It is recommended that the lower one of the two seals be loosened to allow the cooling water to drain and to prevent penetration of contaminants into the body of the steady rest.

Set-up princicple SLZN

All steady rests have an engraved identification number. This number must be be provided when ordering replacement parts.

Components SLZN/SLZNB

- | | |
|-------------------------|----------------------|
| 1. Body | 10. Scraper band |
| 2. Carm segment | 11. Axle and rollers |
| 3. Clamping arm outside | 12. Cover |
| 4. Clamping arm center | 13. Cylinder housing |
| 5. Bolt and roller | 14. Cylinder flange |
| 6. Clamping arm arbore | 15. Piston |
| 7. Return lever | 16. Piston rod |
| 8. Roller center | 17. Pressure sleeve |
| 9. Roller | 18. Scraper center |

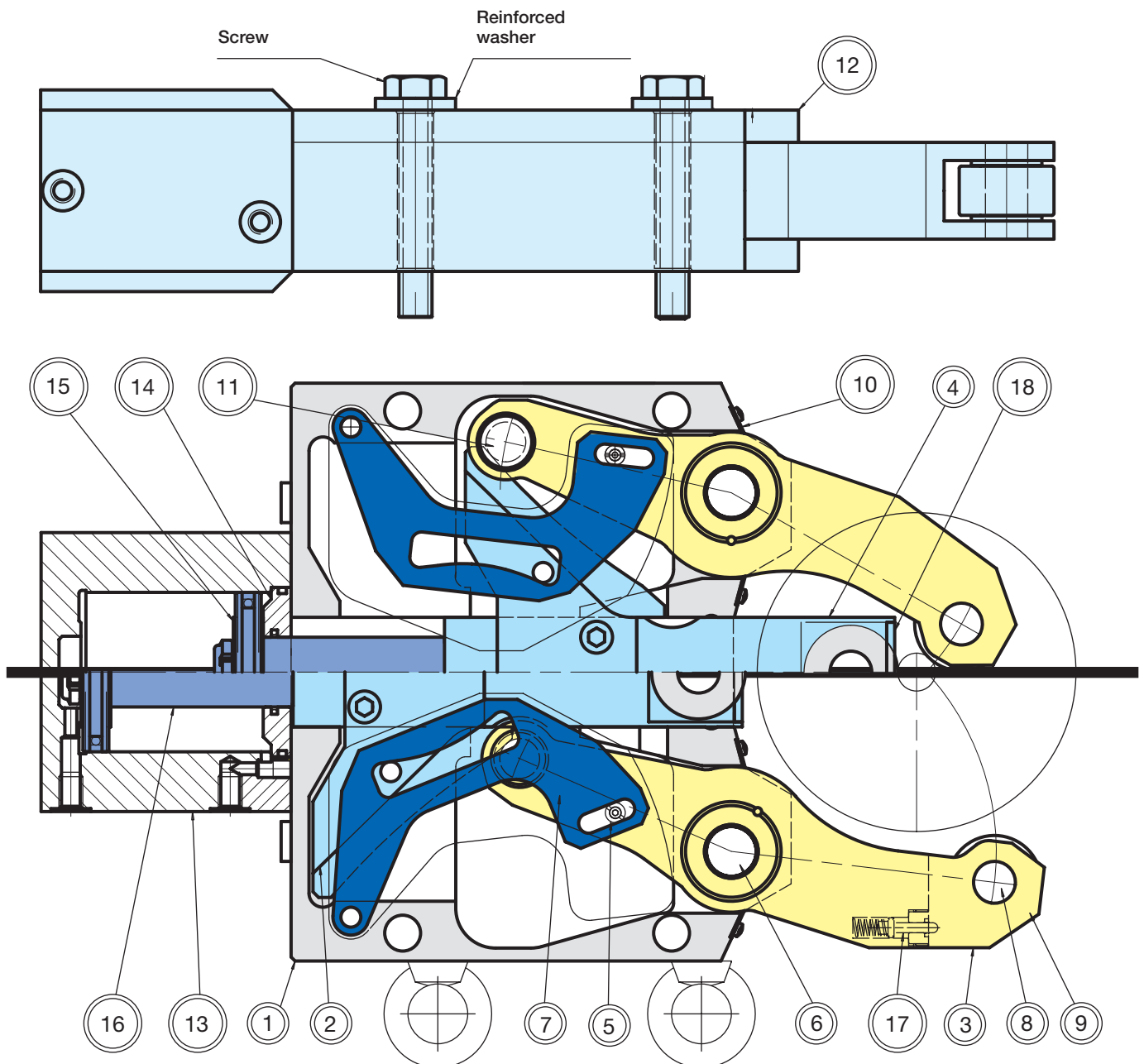



Notes

SLZN - standard design

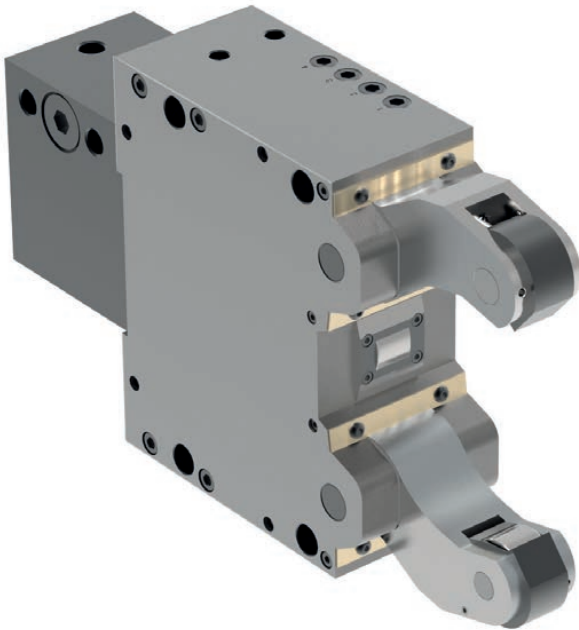

APPLICATION

Support of slender shafts for rational turning and end machining.

TYPE

Standard version with cylinder mounted at rear.

CUSTOMER BENEFITS

- ⊕ Large clamping range without change elements
- ⊕ Operational safety thanks to safety valve, even if pressure drops (SLZ-047 optional)
- ⊕ Compact and sturdy design for variable use
- ⊕ High centering precision and repeatability thanks to proven cam lever system
- ⊕ Resilient chip protection for optimal workpiece wiping (for version „with chip protection“)
- ⊕ Purge air connection to prevent penetration of dirt inside the steady rest

TECHNICAL FEATURES

- Central lubrication or manual lubrication possible, depending on the operating conditions
- Standard version available with cylindrical or convex rollers
- Available with and without chip protection
- Prepared for end position check, except SLZ-047 (limit switch not included in the scope of delivery)

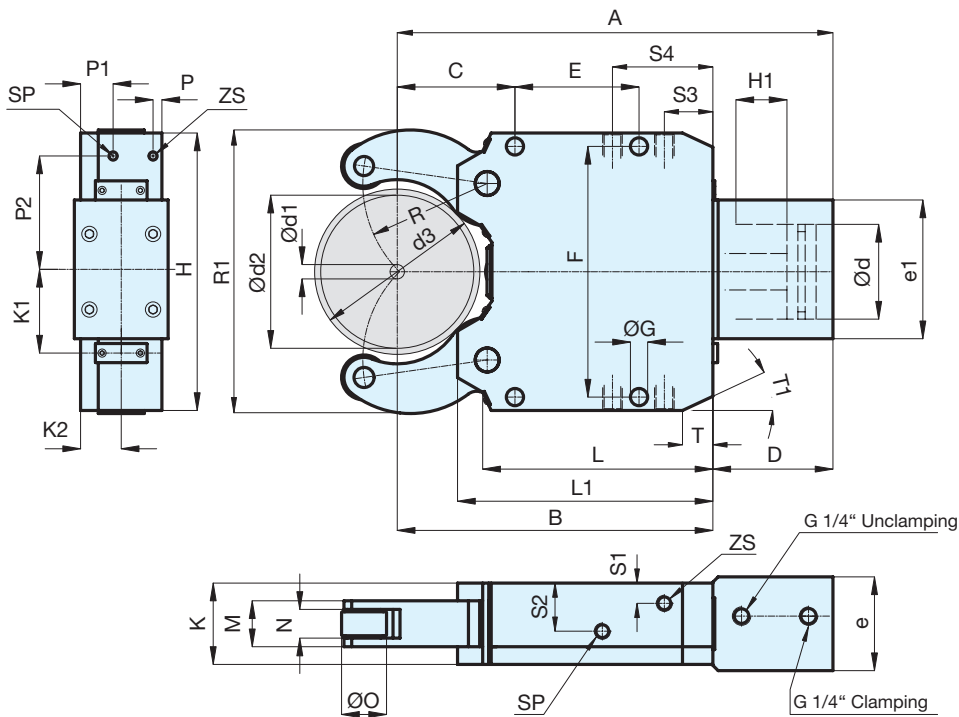

SLZN - standard design

C 15

Self-centering steady rests **SLZN** - oil or air operated with mounted cylinder

Spannbereiche Typ	SLZ 047	SLZN 067	SLZN 08105	SLZN 1152	SLZN 1517	SLZN 40200	SLZN 325	SLZN 50315	SLZN 85350
Clamping range - with chip protection mm	15-62	11-70	16-101	22-140	25-158	40-195	40-240	50-305	85-345
Clamping range - without chip protection mm	4-70	6-75	8-105	11-152	15-170	40-200	30-250	50-315	85-350
Max. radial clamping range - d ₃ mm	70	79	105	161	170	200	250	320	350
With chip protectors RZ	685751	1685567	1685571	1685575 ▲	1685579 ▲	1685583 ▲	1685587 ▲	1685591 ▲	1685595 ▲
With chip protectors RB	-	1685568	1685572	1685576 ▲	1685580 ▲	1685584 ▲	1685588 ▲	1685592 ▲	1685596 ▲
Without chip protectors RZ	685753	1685569	1685573	1685577 ▲	1685581 ▲	1685585 ▲	1685589 ▲	1685593 ▲	1685597 ▲
Without chip protectors RB	-	1685570	1685574	1685578 ▲	1685582 ▲	1685586 ▲	1685590 ▲	1685594 ▲	1685598 ▲
d1 mm	4	6	8	11	15	40	30	50	85
d2 mm	70	75	105	152	170	200	250	315	350
d3 mm	70	79	105	161	170	200	250	315	350
A mm	206	214	279,5	432,5	440,5	459,5	617,5	699	716,5
B mm	137	149	197	306	314	333	448	510	530
C mm	51	52	70	115	123	138	146	203	198
D mm	69	65	82,5	126,5	126,5	126,5	162	186,5	186,5
E mm	64	66	85	135	135	135	240	270	270
F mm	118	140	170	262	262	262	365	400	400
G mm	11	11	14	18	18	18	23	23	23
H mm	132	160	190	290	290	290	400	440	440
K mm	54	63	75	85	85	85	110	145	145
L mm	102	108,5	146	223	223	223	328,5	353,5	353,5
L1 mm	115,5	125,5	164	251	251	251	361	394,5	394,5
Clamping arm width M mm	20	28	35	48	48	48	60	75	75
Roller width N mm	11,5/9	17,5/14	20,5/18	30/25	30/25	30/25	40/35	45/40	45/40
O mm	19	24	35	47	47	47	52	60	60
P mm	-	9,75	-	9,5	9,5	9,5	12,5	21,5	21,5
P1 mm	-	8,75	-	34	34	34	12,5	68,5	68,5
P2 mm	-	51,5	-	117,5	117,5	117,5	160	183	183
R mm	48,5	55	74,5	122	130	143,5	178,5	209	229
S1 mm	8	-	10	-	-	-	-	-	-
S2 mm	23	-	40	-	-	-	-	-	-
S3 mm	10	-	28	-	-	-	-	-	-
S4 mm	34,5	-	28	-	-	-	-	-	-
K ₁ mm	-	51,5	59,5	85	85	85	110	140	140
K2 mm	-	31	36,5	42,5	42,5	42,5	55	59,5	59,5
d mm	40	35	50	80	80	80	100	100	100
e mm	60	62	68	98	98	98	124	142	143
e1 mm	87	22	92	145	145	145	136	156	175
T mm	-	-	-	-	-	-	45	31,5	54,5/22
T1	-	-	-	-	-	-	30°	30°	18°/40°
R1 mm	121	144	190	291	303	326	394	483	512
Weight kg	7	10	14,5	47	47	48	115	185	188
ZS	M 10x1	G 1/8"	G 1/8"	G 1/8"	G 1/8"	G 1/8"	G 1/8"	G 1/8"	G 1/8"
SP	G 1/8"	G 1/8"	G 1/8"	G 1/8"	G 1/8"	G 1/8"	G 1/8"	G 1/8"	G 1/8"
Cylinder-Ø	C40	C 35	C50	C80	C80	C80	C100	C100	C100
Cylinder surface area cm ²	12,5	9,6	19,6	50	50	50	78,5	78,5	78,5
Max. operating pressure bar	25	54	53	62	68	40	57	80	61
Operating pressure bar	6-20	6-30	8-30	8-40	8-44	8-25	8-42	8-58	8-40
Clamping force per roller at max. operating pressure N	830	960	1960	6500	6500	4160	11000	15000	10460
Max. permissible clamping force per roller N	1040	1700	3500	10000	10000	6670	15000	20000	16000
Clamping force per roller at 20 bar N	830	640	1300	3300	3300	3300	5200	5200	5200
Centering accuracy over the entire clamping range mm	0,02*	0,02*	0,02*	0,04*	0,04*	0,04*	0,05*	0,06*	0,06*
Repeat accuracy for the same clamping-Ø at the same operating pressure mm	0,005	0,005	0,005	0,005	0,005	0,005	0,005	0,01	0,01
Max. roller peripheral speed m/min	800	800	800	725	725	725	715	700	700
Max. roller peripheral speed at half the max. clamping force per roller m/min	900	900	950	875	875	875	860	850	850
Displacement of the geometrical workpiece center in the event of a 20-70% change in the operating pressure /at constant force) mm	0,02	0,02	0,02	0,03	0,03	0,03	0,03	0,03	0,03

*1) At constant pressure and clamping force

Self-centering steady rests SLZN

Accessories SLZN

C 15 Cylindrical rollers



Item no.	For	A mm	B mm	Ø F mm	Ø O mm	Ø E mm	R mm
735120	SLZ 047	20	11,5	6	19	6	500
1835444 ▲	SLZN 067	28	17,5	8	24	8	500
1835388	SLZN/SLZNB 08105	31	20,5	15	35	15	500
649513	SLZN/SLZNB 1152, SLZN/SLZNB 1517, SLZN/SLZNB 40200	48	30	20	47	21	1000
649514	SLZN/SLZNB 325	60	40	20	52	21	3000
381420	SLZN/SLZNB 50315, SLZN/SLZNB 85350	75	45	20,1	60	21	3000

Rollers SLZ 047 and SLZNB 08105 without axle

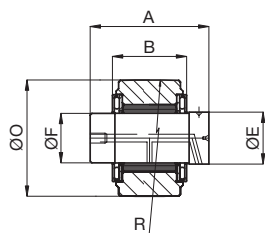

C 15 Convex rollers

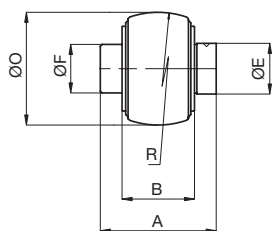

Item no.	For	A mm	B mm	Ø F mm	Ø O mm	Ø E mm	R mm
1835572 ▲	SLZN 067	28	17,5	8	24	8	100
1835513	SLZN/SLZNB 08105	31	20,5	15	35	15	100
649515	SLZN/SLZNB 1152, SLZN/SLZNB 1517, SLZN/SLZNB 40200	48	30	20	47	21	100
649516	SLZN/SLZNB 325	60	40	20	52	21	100
381426	SLZN/SLZNB 50315, SLZN/SLZNB 85350	75	45	20,1	60	21	500

C 15 Central scraper RZ

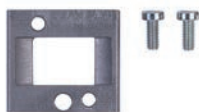

Item no.	For	Clamping ranges D1C mm	Clamping ranges D2C mm
836591	SLZ 047	15	62
1835423	SLZN 067	11	70
1835391	SLZN/SLZNB 08105	16	101
1831222	SLZN/SLZNB 1152	22	140
1831134	SLZN/SLZNB 1517, SLZN/SLZNB 40200	25/40	158/195
735005	SLZN/SLZNB 325	40	240
836584	SLZN/SLZNB 50315, SLZN/SLZNB 85350	50/85	305/345

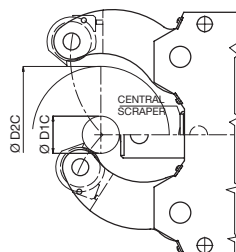

Accessories SLZN

C 15
Central scraper RB

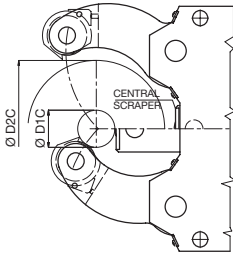

Item no.	For	Clamping ranges D1C mm	Clamping ranges D2C mm
1835573	SLZN/SLZNB 067	11	70
1835606	SLZN/SLZNB 08105	16	101
1831220	SLZN/SLZNB 1152	22	140
1831282	SLZN/SLZNB 1517, SLZN/SLZNB 40200	25/40	158/195
1831403	SLZN/SLZNB 325	40	240
836820	SLZN 50315, SLZN 85360	50/85	305/345

C 15
Chip protector outer Set = 2 Pieces



Item no.	For	Clamping ranges D1C mm	Clamping ranges D2C mm
836609	SLZ 047	15	62
1835435 ▲	SLZN 067	11	70
836610	SLZN/SLZNB 08105	16	101
836611	SLZN/SLZNB 1152, SLZN/SLZNB 1517, SLZN/SLZNB 40200	22/25/40	140/158/195
836612	SLZN/SLZNB 325	40	240
836613	SLZN/SLZNB 50315, SLZN/SLZNB 85350	50/85	305/345

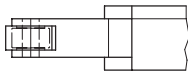
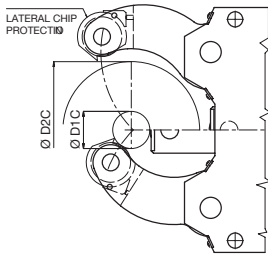

SLZNB - with side mounted cylinder

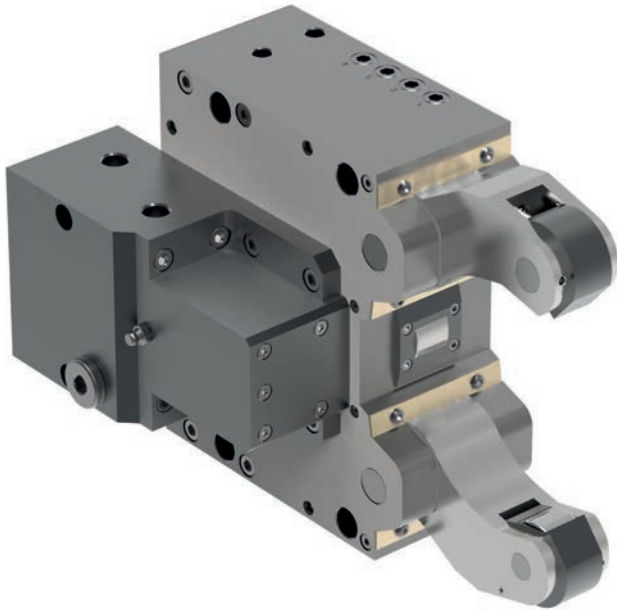

APPLICATION

Support of slender shafts for rational turning and end machining.

TYPE

Standard version with side mounted cylinder.

CUSTOMER BENEFITS

- ⊕ Flexible use when less back-space available
- ⊕ Large clamping range without change elements
- ⊕ Operational safety thanks to safety valve, even if pressure drops
- ⊕ High centering precision and repeatability thanks to proven cam lever system
- ⊕ Resilient chip protection for optimal workpiece wiping (for version „with chip protection“)
- ⊕ Purge air connection to prevent penetration of dirt inside the steady rest

TECHNICAL FEATURES

- Central lubrication or manual lubrication possible, depending on the operating conditions
- Standard version available with cylindrical or convex rollers
- Available with and without chip protection
- Prepared for end position check (limit switch not included in the scope of delivery)

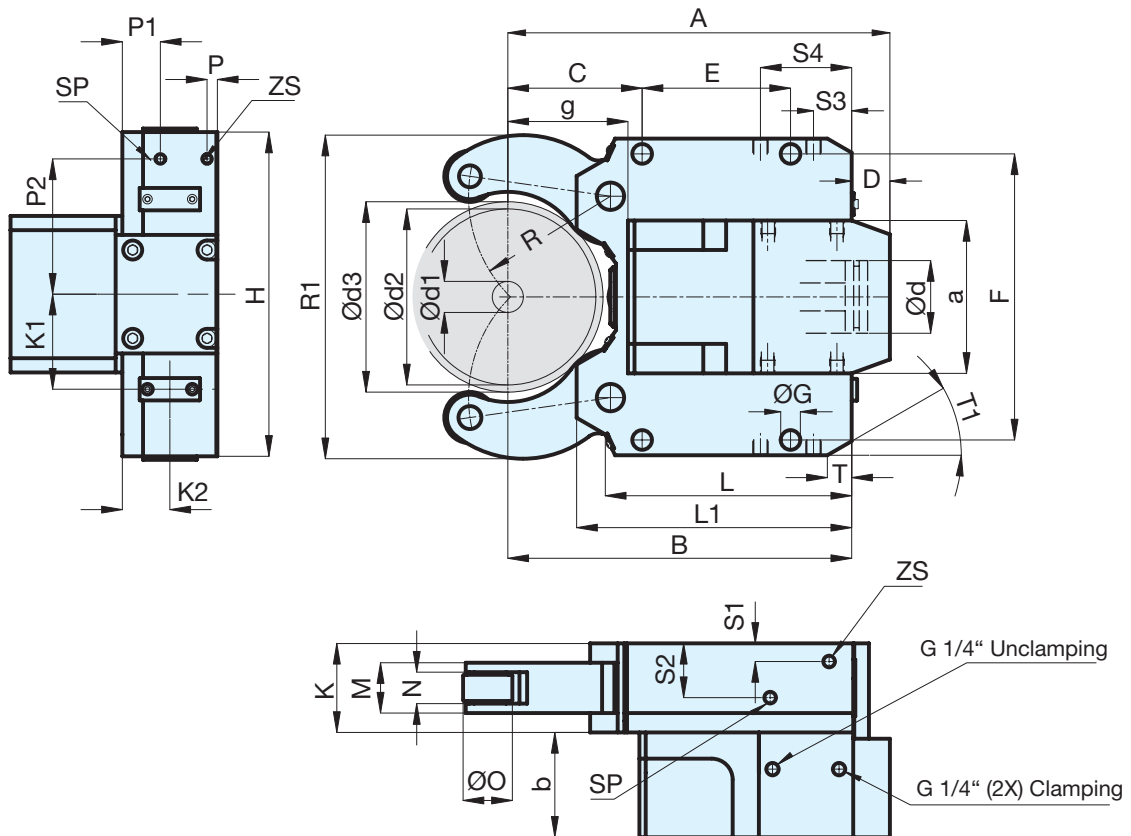

SLZNB - with side mounted cylinder

C 15

 Self-centering steady rests **SLZNB** - oil or air operated, with side mounted cylinder

Spannbereiche Typ	SLZNB 08105	SLZNB 1152	SLZNB 1517	SLZNB 40200	SLZNB 325	SLZNB 50315	SLZNB 85350
Clamping range - with chip protection mm	16-101	22-140	25-158	40-195	40-240	50-305	85-345
Clamping range - without chip protection mm	8-105	11-152	15-170	40-200	30-250	50-315	85-350
Max. radial clamping range - d ₃ mm	105	161	170	200	250	320	350
With chip protectors RZ	1685539 ▲	1685543 ▲	1685547 ▲	1685551 ▲	1685555 ▲	1685559 ▲	1685563 ▲
With chip protectors RB	1685540 ▲	1685544 ▲	1685548 ▲	1685552 ▲	1685556 ▲	1685560 ▲	1685564 ▲
Without chip protectors RZ	1685541 ▲	1685545 ▲	1685549 ▲	1685553 ▲	1685557 ▲	1685561 ▲	1685565 ▲
Without chip protectors RB	1685542 ▲	1685546 ▲	1685550 ▲	1685554 ▲	1685558 ▲	1685562 ▲	1685566 ▲
d1 mm	8	11	15	40	30	50	85
d2 mm	105	152	170	200	250	315	350
d3 mm	105	161	170	200	250	320	350
A mm	228	341	349	368	483,5	574	594
B mm	197	306	314	333	448	510	530
C mm	70	115	123	138	146	178	198
D mm	31	35	35	35	35,5	64	64
E mm	85	135	135	135	240	270	270
F mm	170	262	262	262	365	400	400
G mm	14	18	18	18	23	23	23
H mm	190	290	290	290	400	440	440
K mm	75	85	85	85	110	145	145
L mm	146	223	223	223	328,5	353,5	353,5
L1 mm	164	251	251	251	361	394,5	394,5
Clamping arm width M mm	35	48	48	48	60	75	75
Roller width N mm	20,5/18	30/25	30/25	30/25	40/35	45/40	45/40
O mm	35	47	47	47	52	60	60
P mm	-	9,5	9,5	9,5	12,5	21,5	21,5
P1 mm	-	34	34	34	12,5	68,5	68,5
P2 mm	-	117,5	117,5	117,5	160	183	183
R mm	74,5	122	130	143,5	178,5	209	229
S1 mm	10	-	-	-	-	-	-
S2 mm	40	-	-	-	-	-	-
S3 mm	28	-	-	-	-	-	-
S4 mm	28	-	-	-	-	-	-
K ₁ mm	59,5	85	85	85	110	140	140
K2 mm	36,5	42,5	42,5	42,5	55	59,5	59,5
a mm	95	140	140	140	180	180	180
b mm	71	98	98	98	124	143	143
d mm	50	80	80	80	100	100	100
g mm	68	102	110	129	169	196	216
T mm	-	-	-	-	48	54,5/22	54,5/22
T1	-	-	-	-	30°	18°/40°	18°/40°
R1 mm	192	291	303	326	403	486	512
Weight kg	14,5	51	51	52	134	194	198
ZS	G 1/8"	G 1/8"	G 1/8"	G 1/8"	G 1/8"	G 1/8"	G 1/8"
SP	G 1/8"	G 1/8"	G 1/8"	G 1/8"	G 1/8"	G 1/8"	G 1/8"
Cylinder-Ø	C50	C80	C80	C80	C100	C100	C100
Cylinder surface area cm ²	19,6	50	50	50	78,5	78,5	78,5
Max. operating pressure bar	53	62	68	40	57	80	61
Operating pressure bar	8-30	8-40	8-44	8-25	8-42	8-58	8-40
Clamping force per roller at max. operating pressure N	1960	6500	7000	4160	11000	15000	10460
Max. permissible clamping force per roller N	3500	10000	10000	6670	15000	20000	16000
Clamping force per roller at 20 bar N	1300	3300	3300	3300	5200	5200	5200
Centering accuracy over the entire clamping range mm	0,02*	0,04*	0,04*	0,04*	0,05*	0,06*	0,06*
Repeat accuracy for the same clamping-Ø at the same operating pressure mm	0,005	0,005	0,005	0,005	0,01	0,01	0,01
Max. roller peripheral speed m/min	800	725	725	725	715	700	700
Max. roller peripheral speed at half the max. clamping force per roller m/min	950	875	875	875	860	850	850
Displacement of the geometrical workpiece center in the event of a 20-70% change in the operating pressure /at constant force) mm	0,02	0,03	0,03	0,03	0,03	0,03	0,03

*) At constant pressure and clamping force

Accessories SLZNB

C 15 Cylindrical rollers



Item no.	For	A mm	B mm	Ø F mm	Ø O mm	Ø E mm	R mm
1835388	SLZN/SLZNB 08105	31	20,5	15	35	15	500
649513	SLZN/SLZNB 1152, SLZN/SLZNB 1517, SLZN/SLZNB 40200	48	30	20	47	21	1000
649514	SLZN/SLZNB 325	60	40	20	52	21	3000
381420	SLZN/SLZNB 50315, SLZN/SLZNB 85350	75	45	20,1	60	21	3000

Rollers SLZNB 08105 without axle

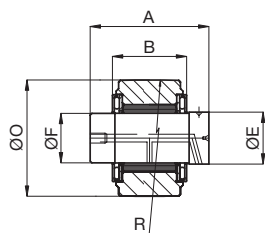

C 15 Convex rollers

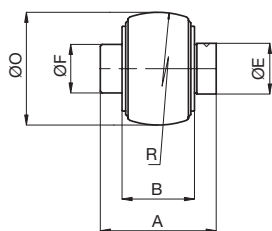

Item no.	For	A mm	B mm	Ø F mm	Ø O mm	Ø E mm	R mm
1835513	SLZN/SLZNB 08105	31	20,5	15	35	15	100
649515	SLZN/SLZNB 1152, SLZN/SLZNB 1517, SLZN/SLZNB 40200	48	30	20	47	21	100
649516	SLZN/SLZNB 325	60	40	20	52	21	100
381426	SLZN/SLZNB 50315, SLZN/SLZNB 85350	75	45	20,1	60	21	500

C 15 Central scraper RZ



Item no.	For	Clamping ranges D1C mm	Clamping ranges D2C mm
1835391	SLZN/SLZNB 08105	16	101
1831222	SLZN/SLZNB 1152	22	140
1831134	SLZN/SLZNB 1517, SLZN/SLZNB 40200	25/40	158/195
735005	SLZN/SLZNB 325	40	240
836584	SLZN/SLZNB 50315, SLZN/SLZNB 85350	50/85	305/345

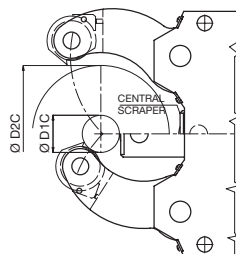

Accessories SLZNB

C 15
Central scraper RB

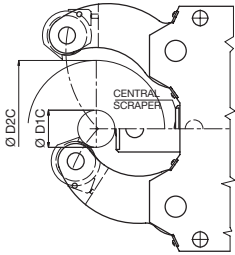

Item no.	For	Clamping ranges D1C mm	Clamping ranges D2C mm
1835606	SLZN/SLZNB 08105	16	101
1831220	SLZN/SLZNB 1152	22	140
1831282	SLZN/SLZNB 1517, SLZN/SLZNB 40200	25/40	158/195
1831403	SLZN/SLZNB 325	40	240
836820	SLZN 50315, SLZN 85360	50/85	305/345

C 15
Chip protector outer Set = 2 Pieces

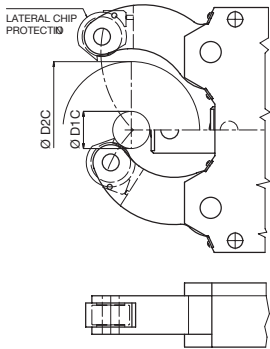

Item no.	For	Clamping ranges D1C mm	Clamping ranges D2C mm
836610	SLZN/SLZNB 08105	16	101
836611	SLZN/SLZNB 1152, SLZN/SLZNB 1517, SLZN/SLZNB 40200	22/25/40	140/158/195
836612	SLZN/SLZNB 325	40	240
836613	SLZN/SLZNB 50315, SLZN/SLZNB 85350	50/85	305/345

SLZ - heavy design

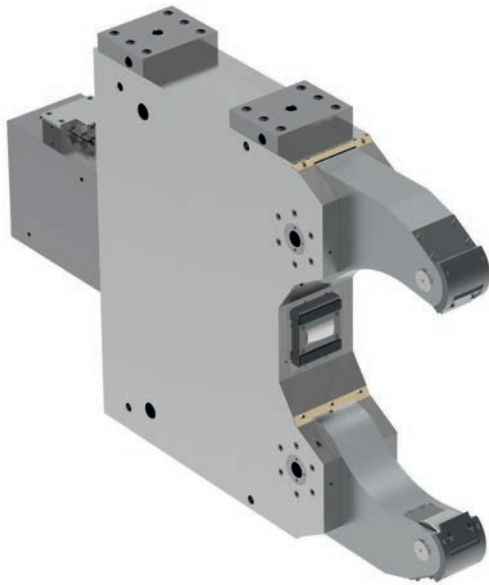

APPLICATION

Support of shafts for rational turning and end machining preferential for heavy solid materials.

TYPE

Heavy design for high loads.

CUSTOMER BENEFITS

- ⊕ Large clamping range without change elements
- ⊕ Operational safety thanks to safety valve, even if pressure drops
- ⊕ Sturdy design for variable use - Increased stability thanks to steady rest fastened with clamping arm axis
- ⊕ High centering precision and repeatability thanks to proven cam lever system
- ⊕ Resilient chip protection for optimal workpiece wiping (for version „with chip protection“)
- ⊕ Purge air connection to prevent penetration of dirt inside the steady rest

TECHNICAL FEATURES

- Central lubrication or manual lubrication possible, depending on the operating conditions
- Standard version available with cylindrical or convex rollers
- Available with and without chip protection
- Prepared for end position check (limit switch not included in the scope of delivery)
- Recommendation: Higher precision in case of vertical installation of the steady rest

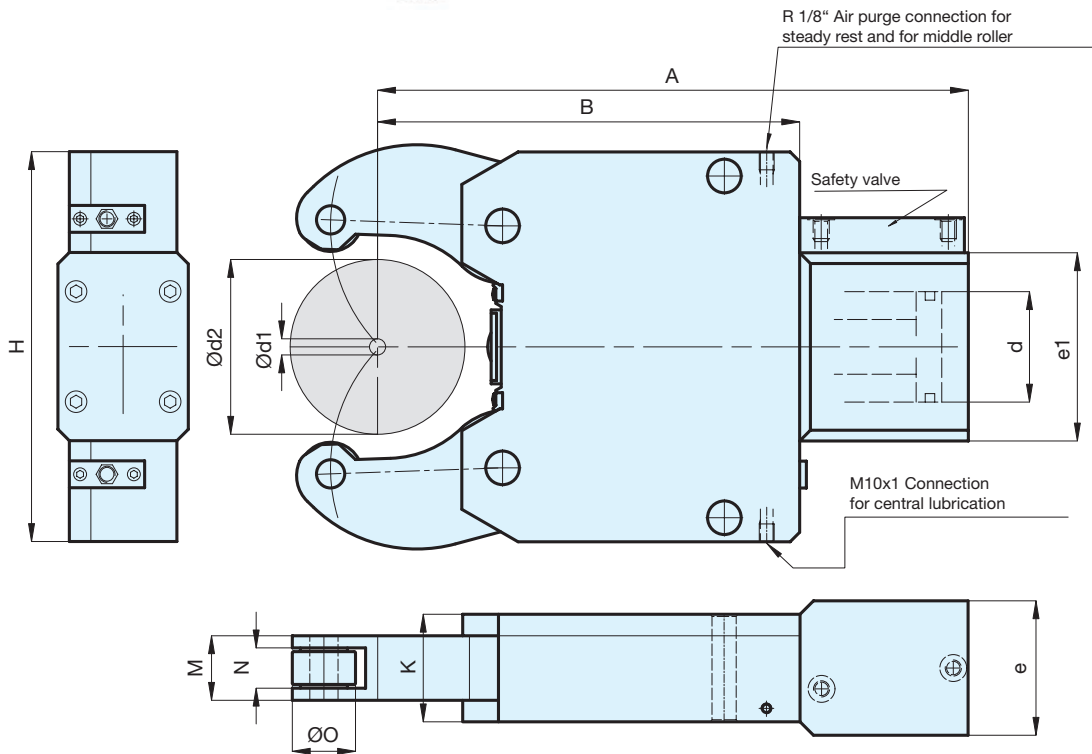

Self-centering steady rests SLZ - heavy design

SLZ - heavy design

C 15

Self-centering steady rests **SLZ heavy design** - oil or air operated, heavy design for high loads

Spannbereiche Typ	SLZ 437	SLZ 5040	SLZ 1546	SLZ 1060	SLZ 3580
Clamping range - with chip protection mm	75-350	75-380	150-430	100-590	350-770
Clamping range - without chip protection mm	40-375	50-400	150-460	100-600	350-800
With chip protectors RZ	685899 ▲	1685722 ▲	685897 ▲	685896 ▲	685895 ▲
With chip protectors RB	685894 ▲	685893 ▲	685892 ▲	685891 ▲	685890 ▲
Without chip protectors RZ	685889 ▲	685888 ▲	685887 ▲	685886 ▲	685885 ▲
Without chip protectors RB	685884 ▲	685883 ▲	685882 ▲	685881 ▲	685880 ▲
d1 mm	40	50	150	100	350
d2 mm	370	400	460	600	800
A mm	1086	1100	1110	1465	1810
B mm	762	800	800	1105	1340
H mm	730	730	730	1020	1270
K mm	170	170	170	270	440
Clamping arm width M mm	90	90	90	170	240
Roller width N mm	60/50	60/50	60/50	104/95	150/138
O mm	80	80	80	160	220
d mm	120	120	120	150	180
e mm	150	150	150	260	370
e1 mm	240	240	240	280	320
Weight kg	490	500	570	2000	4000
Cylinder-Ø	C120	C120	C120	C150	C180
Cylinder surface area cm ²	113	113	113	176	254
Max. operating pressure bar	100	100	85	90	98
Operating pressure bar	10-40	10-40	10-40	10-40	10-40
Clamping force per roller at max. operating pressure N	15000	15000	15000	23000	32000
Max. permissible clamping force per roller N	35000	35000	40000	50000	80000
Centering accuracy over the entire clamping range mm	0,04*	0,04*	0,04*	0,04*	0,06*
Repeat accuracy for the same clamping-Ø at the same operating pressure mm	0,01	0,01	0,01	0,01	0,01
Max. roller peripheral speed m/min	725	725	725	725	715
Max. roller peripheral speed at half the max. clamping force per roller m/min	875	875	875	875	860
Displacement of the geometrical workpiece center in the event of a 20-70% change in the operating pressure /at constant force) mm	0,06	0,06	0,06	0,06	0,06

¹⁾ At constant pressure and clamping force

SLZC - extremely compact design

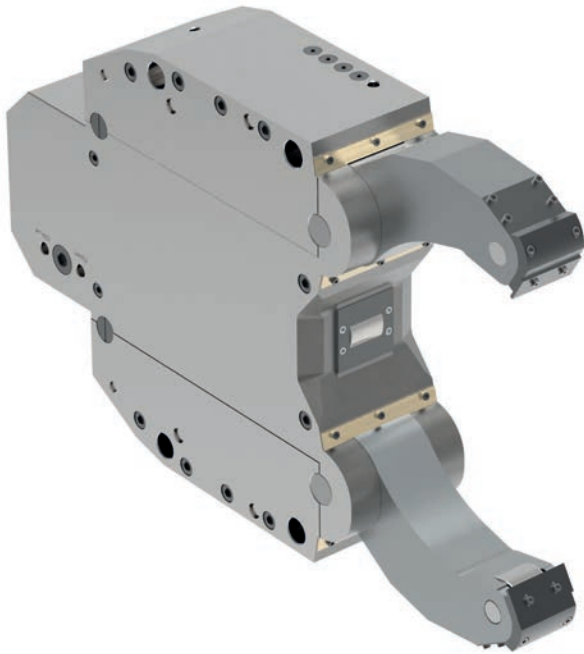

APPLICATION

Support of shafts for rational turning and end machining optimal for pipe materials.

TYPE

Compact series with extra large clamping ranges.

CUSTOMER BENEFITS

- ⊕ Extra large clamping range without change elements
- ⊕ Integrated channels for rinsing the workpiece in the contact area with coolant connection on the rear side
- ⊕ Operational safety thanks to safety valve, even if pressure drops
- ⊕ Extremely compact and sturdy design for variable use
- ⊕ High centering precision and repeatability thanks to proven cam lever system
- ⊕ Resilient chip protection for optimal workpiece wiping (for version „with chip protection“)
- ⊕ Purge air connection to prevent penetration of dirt inside the steady rest

TECHNICAL FEATURES

- Central lubrication or manual lubrication possible, depending on the operating conditions
- Standard version available with cylindrical or convex rollers
- Available with and without chip protection
- Prepared for end position check (limit switch not included in the scope of delivery)

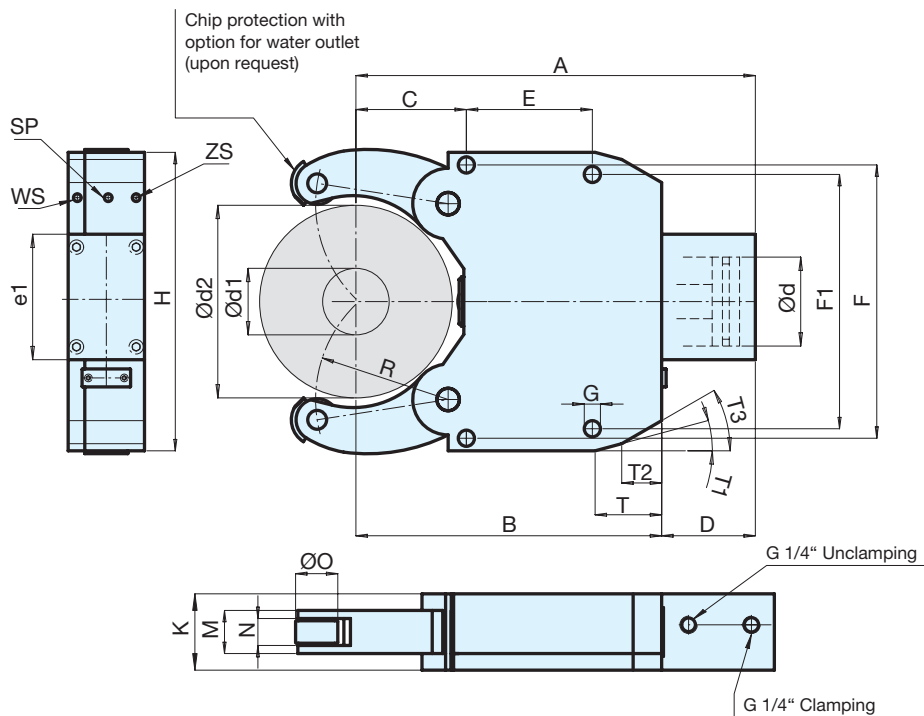

SLZC - extremely compact design

C 15

 Self-centering steady rests **SLZC** - oil or air operated, extremely compact design, developed for minimum mounting dimensions

Spannbereiche Typ	SLZC 60280	SLZC 80390	SLZC 100410	SLZC 135460	SLZC 215510
Clamping range - without chip protection mm	60-280	80-390	100-410	135-460	215-520
With chip protectors RZ	1685616 ▲	1685620 ▲	1685624 ▲	1685628 ▲	1685632 ▲
With chip protectors RB	1685617 ▲	1685621 ▲	1685625 ▲	1685629 ▲	1685633 ▲
Without chip protectors RZ	1685618 ▲	1685622 ▲	1685626 ▲	1685630 ▲	1685634 ▲
Without chip protectors RB	1685619 ▲	1685623 ▲	1685627 ▲	1685631 ▲	1685635 ▲
d1 mm	60	80	100	135	215
d2 mm	280	390	410	460	520
A mm	580	755	763	816	817
B mm	450	607	617	670	685
C mm	168	230	240	215	245
D mm	130	148	146	146	132
E mm	180	240	240	330	300
F mm	360	445	445	640	640
F1 mm	360	445	445	610	610
G mm	23	23	23	27	27
H mm	400	485	485	680	680
K mm	125	150	150	150	150
Clamping arm width M mm	60	75	75	75	75
Roller width N mm	40/35	45/40	45/40	29	29
O mm	52	60	60	80	80
R mm	200	265	275	290	310
d mm	90	100	100	120	120
e1 mm	184	194	194	215	215
T mm	100	130	130	150	150
T1	15°	15°	15°	15°	20°
T2 mm	61	50	50	77	85
T3 mm	30°	30°	30°	30°	30°
Weight kg	85	170	170	390	380
ZS	G 1/8"	G 1/8"	G 1/8"	G 1/8"	G 1/8"
SP	G 1/8"	G 1/8"	G 1/8"	G 1/8"	G 1/8"
WS	G 1/4"	G 1/4"	G 1/4"	G 1/4"	G 1/4"
Operating pressure bar	8-70	8-80	8-80	8-80	8-80
Max. permissible clamping force per roller N	14500	20000	20000	25000	25000
Centering accuracy over the entire clamping range mm	0,05*	0,06*	0,06*	0,06*	0,06*
Repeat accuracy mm	0,007*	0,01*	0,01*	0,01*	0,01*
Max. roller peripheral speed m/min	715	700	700	700	700

* At constant pressure and clamping force

Water connection (WS) on request

SLZK - slim clamping arms

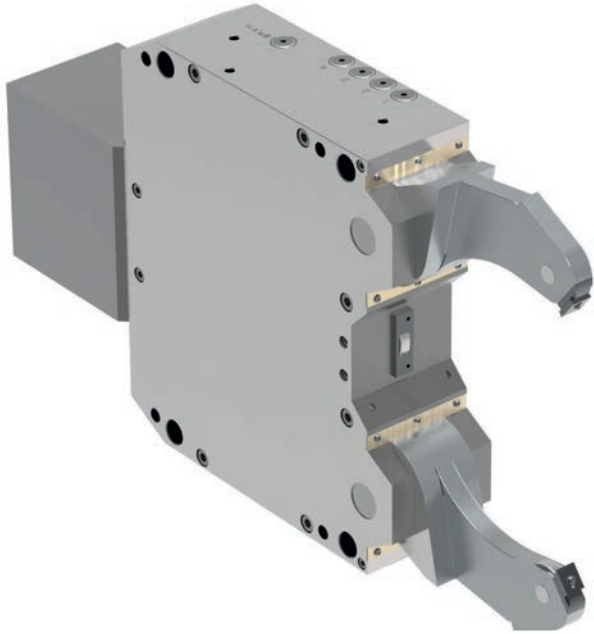

APPLICATION

Support of slender shafts with narrow intermediate distances for rational turning and end machining optimal for crankshafts and cam shafts.

TYPE

Version with extra slim clamping arms.

CUSTOMER BENEFITS

- ⊕ Can be flexibly used thanks to support option in narrow in-between spaces
- ⊕ Large clamping range without change elements
- ⊕ Operational safety thanks to safety valve, even if pressure drops
- ⊕ Compact and sturdy design for variable use
- ⊕ High centering precision and repeatability thanks to proven cam lever system
- ⊕ Resilient chip protection for optimal workpiece wiping (for version „with chip protection“)
- ⊕ Purge air connection to prevent penetration of dirt inside the steady rest

TECHNICAL FEATURES

- Central lubrication or manual lubrication possible, depending on the operating conditions
- Standard version available with cylindrical rollers
- Available with and without chip protection
- Prepared for end position check (limit switch not included in the scope of delivery)

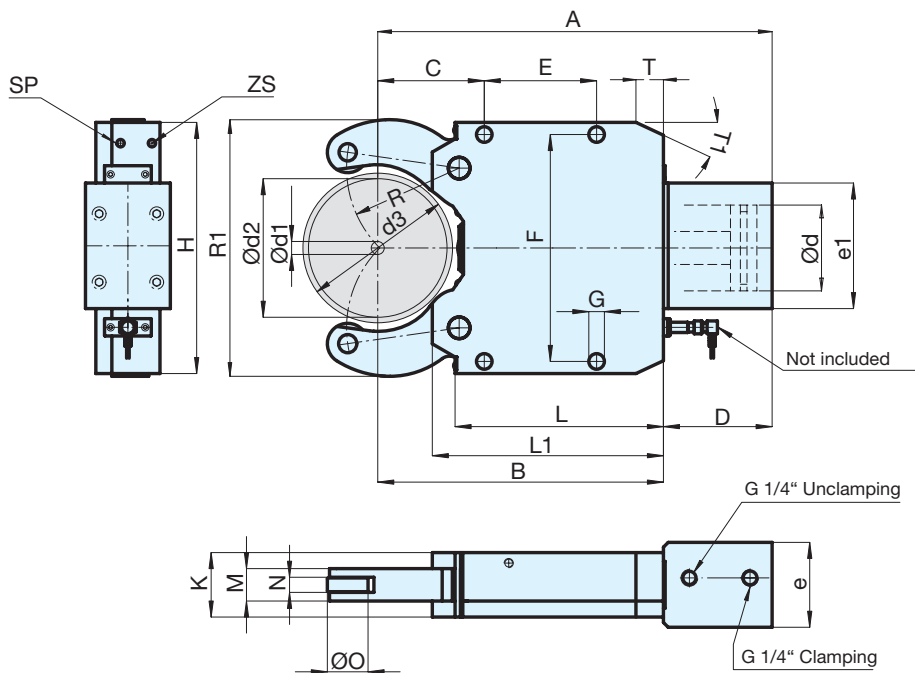

SLZK - slim clamping arms

C 15

 Self-centering steady rests **SLZK** - oil or air operated, with slender clamping arms, for machining crankshafts

Spannbereiche Typ	SLZK 08101-15	SLZK 08101-19	SLZK 08101-22	SLZK 40200-18	SLZK 40200-22	SLZK 325-19	SLZK 325-22	SLZK 325-29
Clamping range - with chip protection mm	16-101	16-101	16-101	30-185	30-185	35-248	35-248	35-248
Clamping range - without chip protection mm	8-105	8-105	8-105	30-185	30-185	35-250	35-250	35-250
With chip protectors RZ	1685636 ▲	1685638 ▲	1685640 ▲	1685642 ▲	1685644 ▲	1685646 ▲	1685648 ▲	1685650 ▲
Without chip protectors RZ	1685637 ▲	1685639 ▲	1685641 ▲	1685643 ▲	1685645 ▲	1685647 ▲	1685649 ▲	1685651 ▲
d1 mm	8	8	8	30	30	35	35	35
d2 mm	105	105	105	185	185	250	250	250
d3 mm	106	106	106	190	190	254	254	254
Max. Ø opening range d4sw mm	113	113	113	200	200	263	263	263
A mm	279,5	279,5	279,5	458,5	458,5	617,5	617,5	617,5
B mm	197	197	197	333	333	451	451	451
C mm	70	70	70	138	138	146	146	146
D mm	82,5	82,5	82,5	125,5	125,5	166,5	166,5	166,5
E mm	85	85	85	135	135	240	240	240
F mm	170	170	170	262	262	365	365	365
G mm	14	14	14	18	18	23	23	23
H mm	190	190	190	290	290	400	400	400
K mm	50	50	50	85	85	110	110	110
L mm	143	143	143	223	223	331,5	331,5	331,5
L1 mm	164	164	164	251	251	364	364	364
Clamping arm width M mm	15	18	22	18	22	19	22	29
Roller width N mm	8	10	13	11	13	11	13	16
O mm	35	35	35	47	47	52	52	52
R mm	74,5	74,5	74,5	143,5	143,5	183	183	183
d mm	50	50	50	60	60	60	60	60
e mm	68	68	68	98	98	124	124	124
e1 mm	92	92	92	145	145	156	156	156
T mm	-	-	-	-	-	45	45	45
T1	-	-	-	-	-	30°	30°	30°
R1 mm	190	190	190	320	320	394	394	394
Weight kg	11,5	11,5	11,5	40	40	80	80	80
ZS	G 1/8"	G 1/8"	G 1/8"	G 1/8"	G 1/8"	G 1/8"	G 1/8"	G 1/8"
SP	G 1/8"	G 1/8"	G 1/8"	G 1/8"	G 1/8"	G 1/8"	G 1/8"	G 1/8"
Operating pressure bar	8-32	8-40	8-50	8-60	8-75	8-70	8-80	8-80
Max. permissible clamping force per roller N	2100	2700	3350	5600	7000	6600	7500	7500
Centering accuracy over the entire clamping range mm	0,03*	0,03*	0,03*	0,05*	0,05*	0,06*	0,06*	0,06*
Repeat accuracy mm	0,007*	0,007*	0,007*	0,007*	0,007*	0,01*	0,01*	0,01*
Max. roller peripheral speed m/min	750	750	750	715	715	700	700	700

*) At constant pressure and clamping force

Grinding steady rest SLVZ



Grinding steady rest SLVZ - with retractable arms

APPLICATION

Grinding machining on CNC grinding machines. As support for long shafts, for internal machining or grinding directly on the seat of the steady rest.

TYPE

Equipped with fine adjustment in X and Y axes. Standard version with carbide jaws. With PKD (diamond) jaws on request.

CUSTOMER BENEFITS

- ⊕ Free work area and automatic workpiece loading thanks to retractable arms in the steady rest body
- ⊕ Small dimensions and high positioning accuracy and repeatability by means of fine adjustment in the X and Y axes

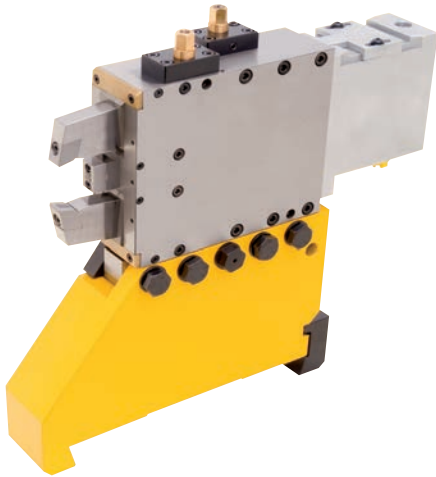

Grinding steady rest SLVZ with extended arms

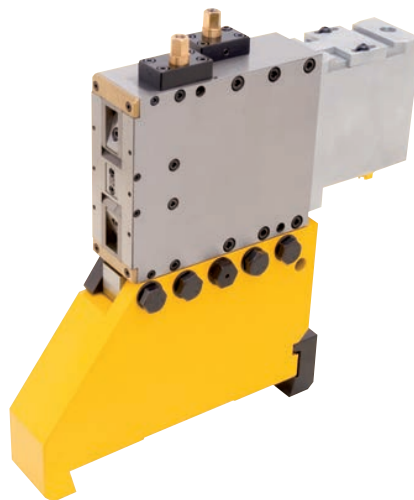

Grinding steady rest SLVZ with retracted arms

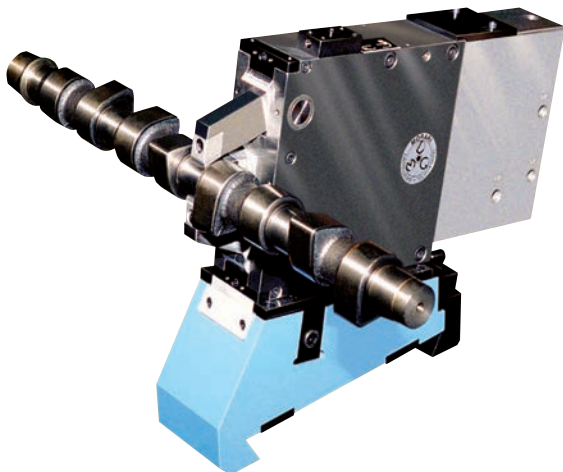

Steady rest SLVZ in use

Grinding steady rest SLVZ

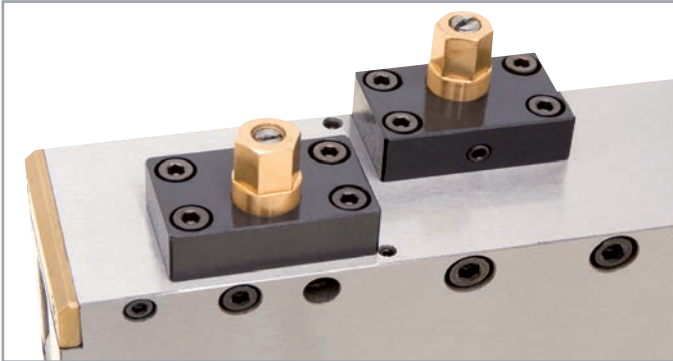

Main features:

- ⌚ Carbide jaws (CBN) or PKD on request (polycrystalline diamond)
- ⌚ Hydraulic or pneumatic actuation
- ⌚ High centering precision
- ⌚ Allows grinding machining on the seat of the steady rest
- ⌚ High repeatability
- ⌚ Stroke control for clamping and open positions
- ⌚ Compact, rigid structure
- ⌚ Customized versions on request

μ-exact fine adjustment for exactly setting up the steady rests. This system allows an easy and quick set-up, if several steady rests are used for the same workpiece. The control system for opening and closing is included in the standard version for all steady rests. The hydraulic or pneumatic connections can be attached according to customer requirements. It is recommended that no pressure changes occur during operation.

Steady rest solutions - on request

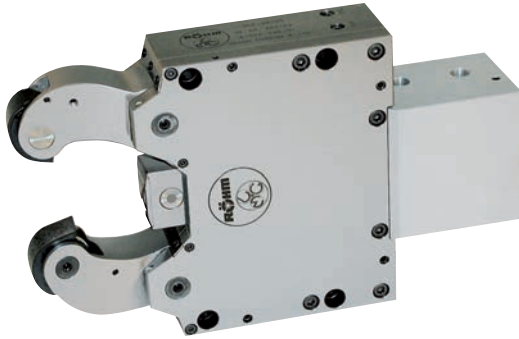

SLZW - One extra opening clamping arm

APPLICATION

For applications where simple loading is decisive.

TYPE

Hydraulically or pneumatically actuated one extra opening clamping arm.

CUSTOMER BENEFITS

- Simple loading of the workpiece

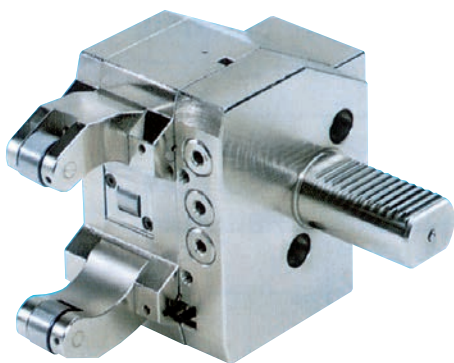
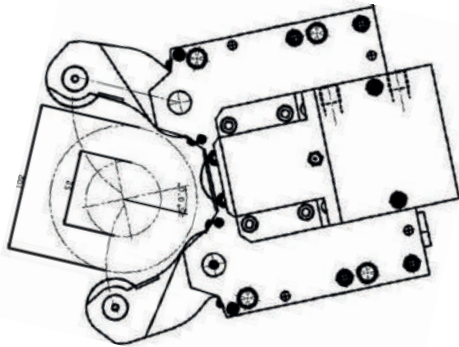

SLZR

APPLICATION

For turret discs of CNC lathes with 4 axes.

TYPE

Hydraulically or pneumatically actuated. Take-up shaft in acc. with DIN 69880.

CUSTOMER BENEFITS

- Rational machining of shaft-type components in 4-axis CNC lathes

Mounting examples

Reaming: crank shafts

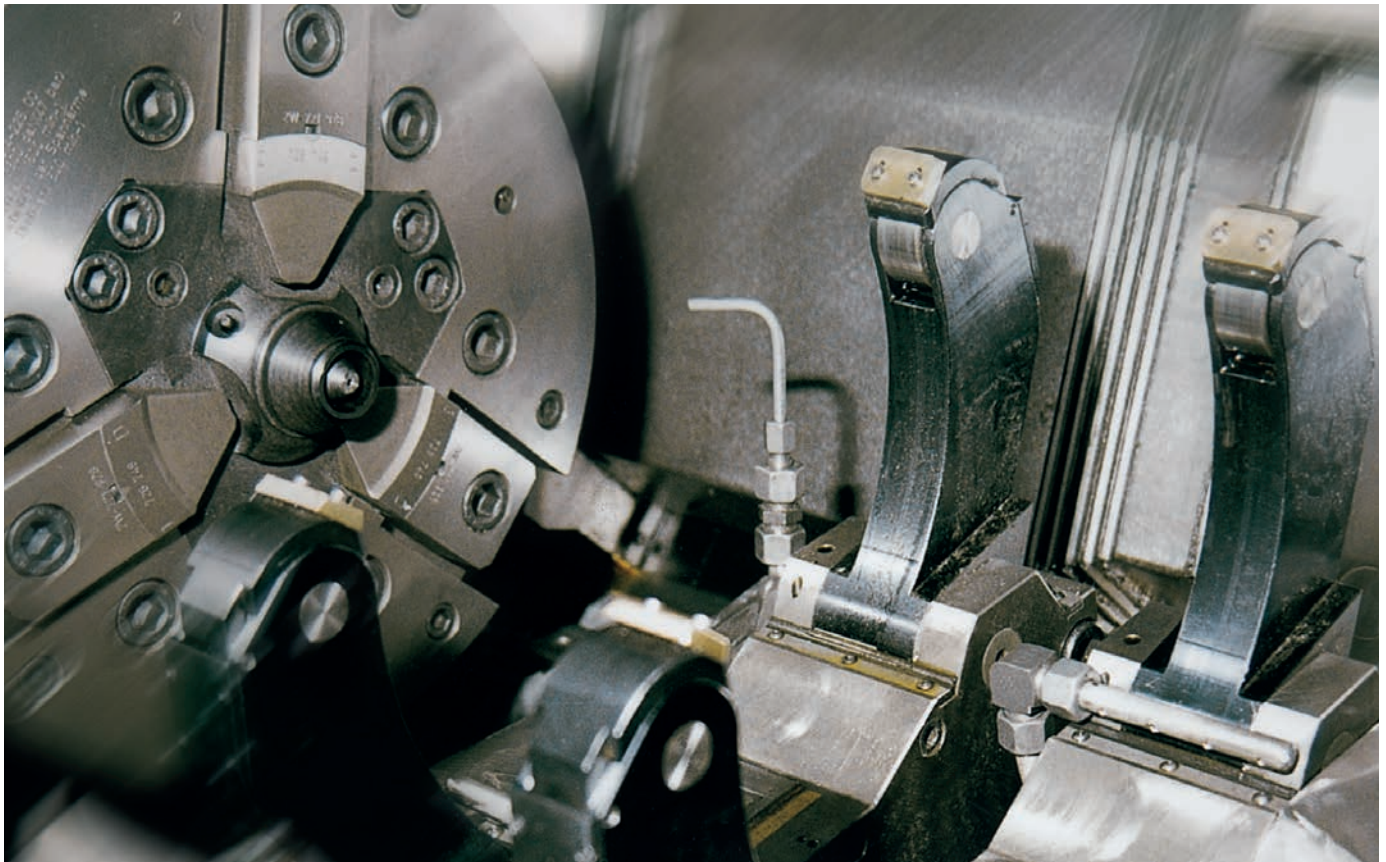

Turning: sleeves

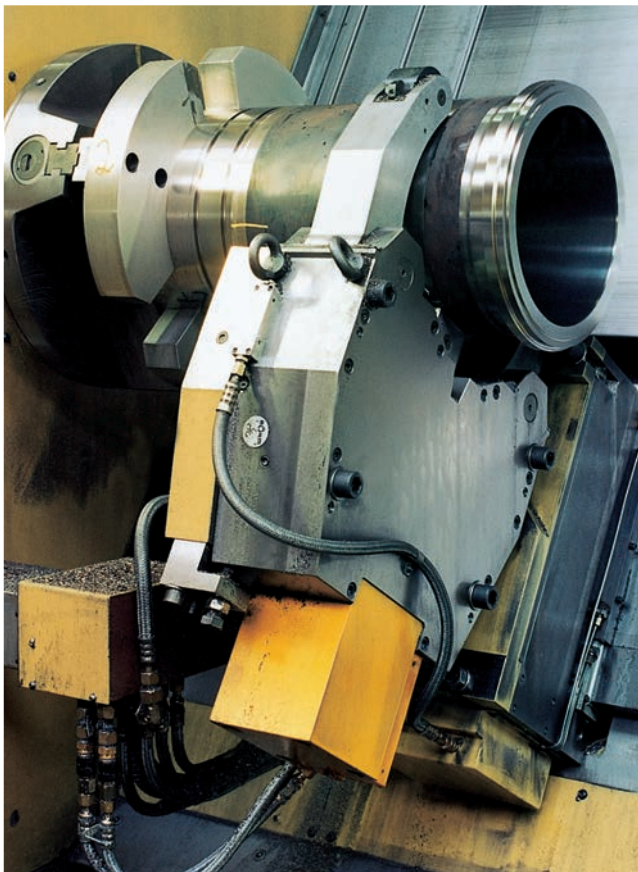

Turning: load hooks

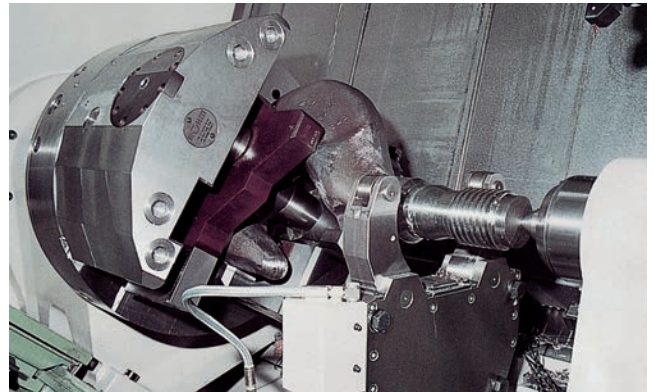

Turning: adaptor cages

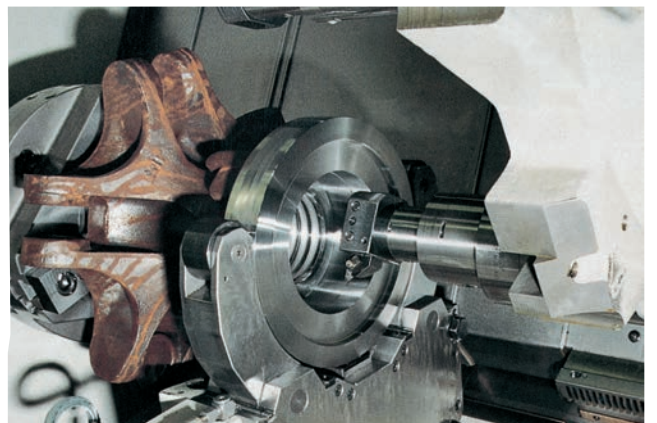

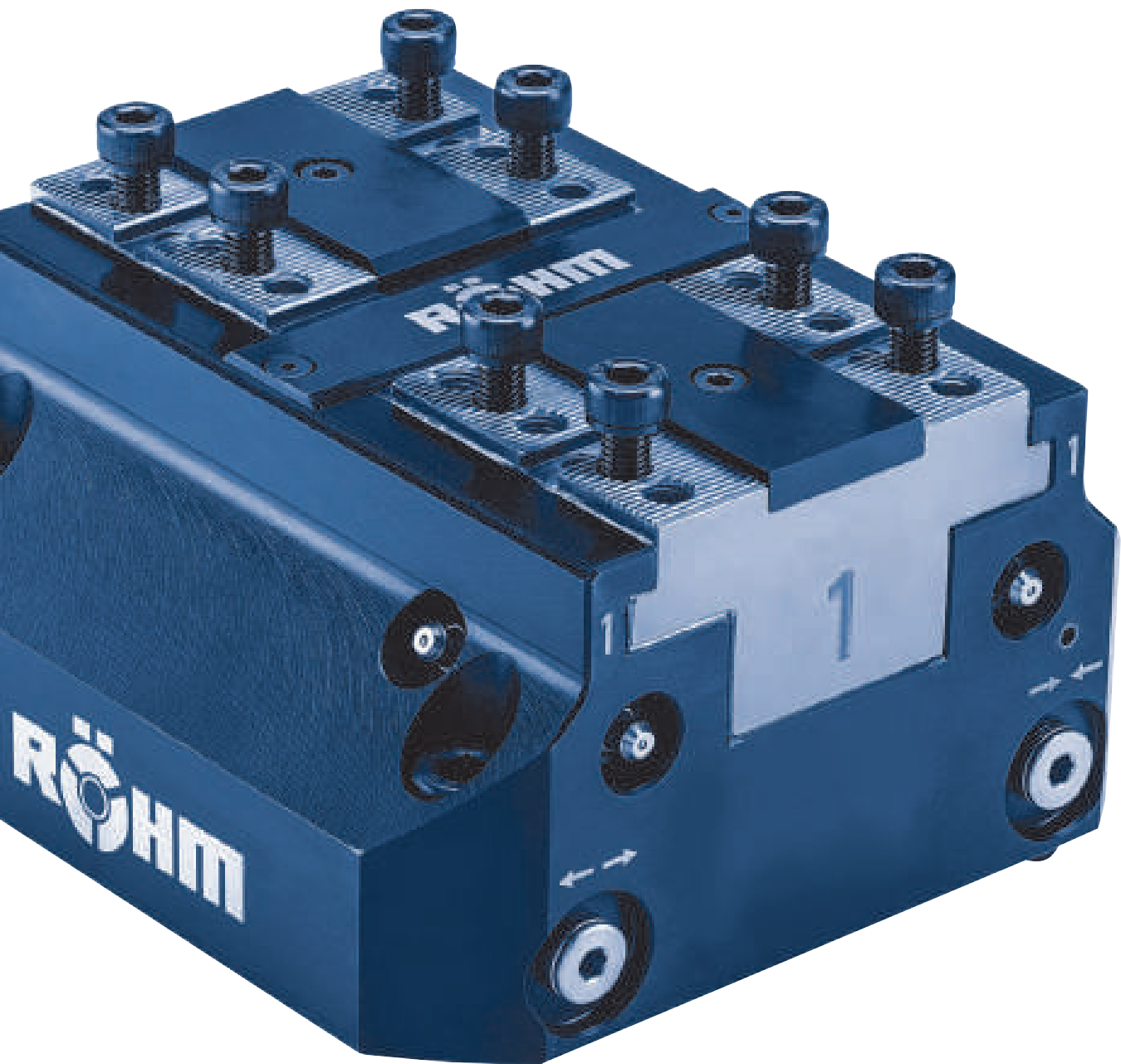

IDEAL FOR STATIONARY USE

The stationary power clamping devices from RÖHM are predestined for stationary, centric clamping of round and angular workpieces on milling machines or machining centers or for the rational clamping in automated work sequences.



Stationary application

STATIONARY POWER CLAMPING DEVICES

Stationary power clamping devices are characterized by many product advantages, which are essential for stationary, centric clamping on milling machines or machining centers or for the rational clamping in automated work sequences: Compact design for best possible work area utilization, high repeatability and constant clamping force at the same pressure, as well as maximum flexibility thanks to the centric clamping of round and angular workpieces.

ADVANTAGES AT A GLANCE

- ⊕ High efficiency thanks to automated and fast clamping in stationary use
- ⊕ Wedge hook system for high load capacity and clamping precision
- ⊕ Flexible use thanks to centric clamping of angular and round components

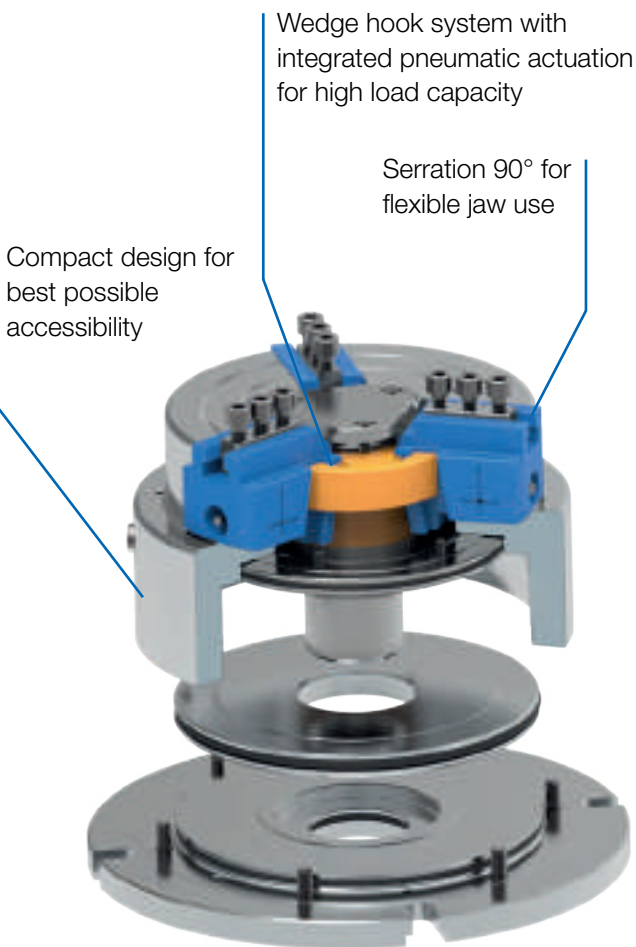

Stationary power chuck SSP

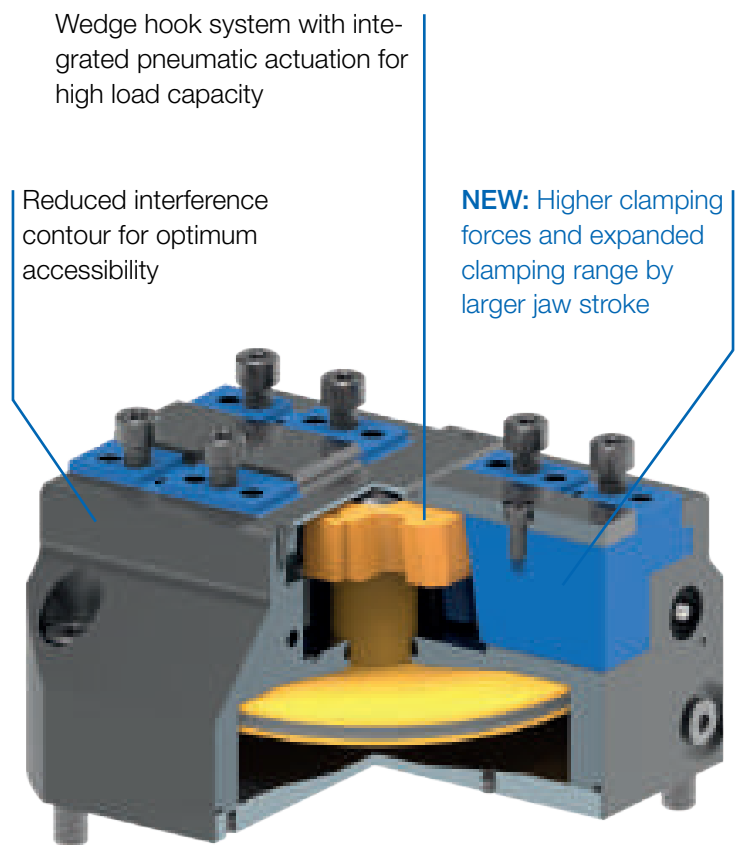

Pneumatically-operated centering vice KZS-P

KZS-P



APPLICATION

Optimally suited for use in 3-, 4- and 5-axis machining centers as well as on all common zero-point clamping systems

TYPE

Pneumatically actuated centering vice in standard design. Optionally with inductive sensors. 2-jaws version.

CUSTOMER BENEFITS

- ⊕ Jaw stroke expanded by up to 20% for a larger clamping range
- ⊕ Highest clamping forces of up to 55 kN, optimal results and process reliability through precision wedge hook system
- ⊕ Optimized lubrication system for constantly high clamping forces
- ⊕ Compact design with reduced interfering contours for optimum workpiece accessibility, ideal working space utilization and optimum chip flow
- ⊕ Sturdy and low-backlash jaw guides for high repeatability

TECHNICAL FEATURES

- Jaws with cross tenon and serration

KZS-P = power-operated, centering, vice, pneumatically



The power-operated centering vices are also available with integrated stroke sensor, which serves for clamping control and ensures optimum process monitoring and thus optimal process reliability.



KZS-P

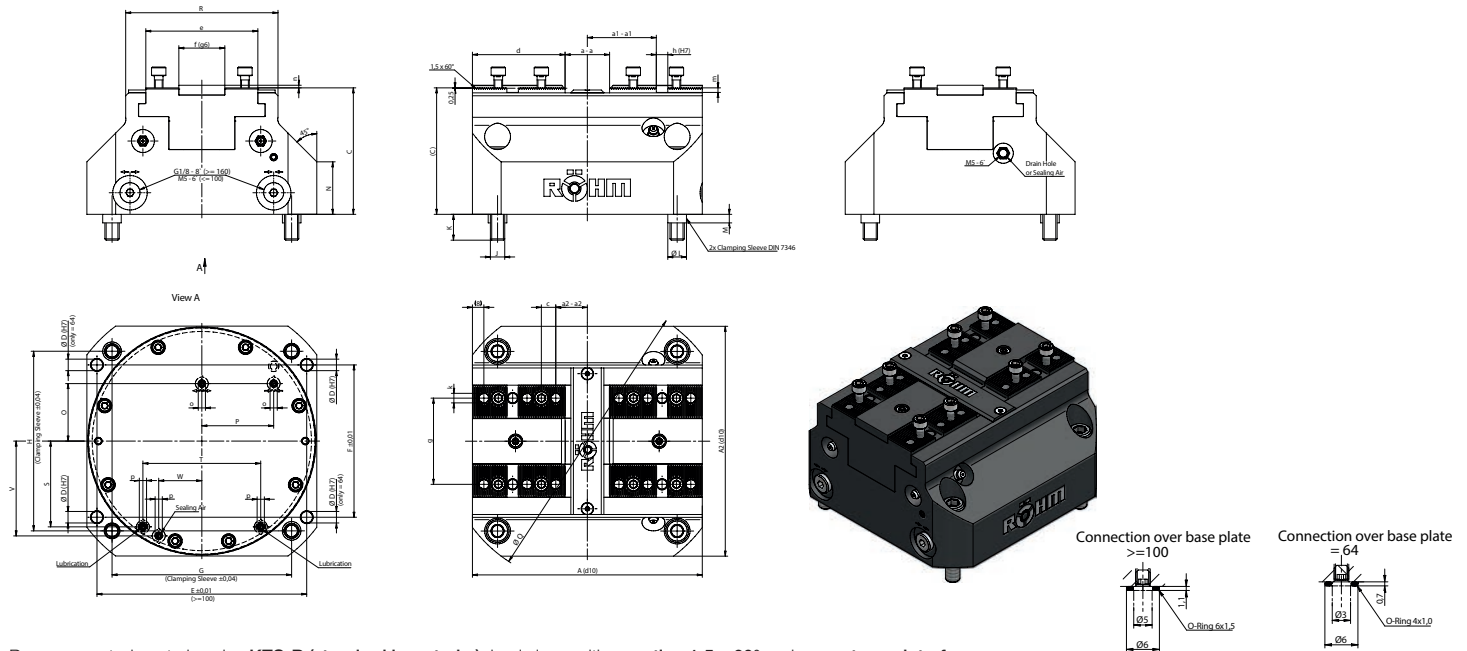

Power-operated centering vice KZS-P (standard jaw stroke), basic jaws with serration 1.5 x 60° and cross-tenon interface

Item No.	181480	181482	181486	181490	181494
Item No. with inductive sensors	181580 ▲	181582 ▲	181586 ▲	181590 ▲	181594 ▲
Size	KZS-P 64	KZS-P 100	KZS-P 160	KZS-P 200	KZS-P 250
A1 mm	64	100	160	200	250
Jaw stroke B mm	2.3	2.3	3.5	4.8	6
C mm	50.7	69.2	82.2	90.2	98.2
D H7 mm	4 - 7.5T	6 - 12T	8 - 14T	8 - 14T	10 - 20T
E±0.01 mm	36	90	146	184	230
F±0.01 mm	56	64	106	146	154
G±0.04 mm	50	80	125	160	200
H±0.04 mm	50	80	125	160	200
J mm	M6	M8	M10	M10	M12
K mm	12	15	18	18	20
L mm	8	11	13	13	16
M mm	4	4.5	6	6	6
N mm	26.2	34.8	31.5	34.2	35.7 (50°)
O mm	17	32	40	50	64
P mm	17	29.5	50	65	75
Q mm	84	130	200	250	310
R mm	45	68	106	140	166
S mm	21.1	34.5	59.7	72.5	92.6
T mm	33.6	55	82	110	139.6
V mm	-27.5	44	74	817.7	110.8
W mm	0	25.5	32	48	60
a mm	12.8 - 17.4	20.4 - 25	24 - 31	34.4 - 44	34 - 46
a1 mm	12.9 - 15.2	25.7 - 28	44.5 - 48	53.2 - 58	55 - 61
a2 mm	9.9 - 12.2	14.7 - 17	18.5 - 22	32 - 27.2	24 - 30
b mm	4.8	5	8	8	11
c mm	5	7	10	10	12
d mm	23.3	37.5	64.5	78	102
e mm	30	47	78	102	125
f ⁹⁰ mm	14	20	32	40	50
g mm	24	35	60	80	90
h ^{H7} mm	4	6	8	8	10
k	M4 - 7T	M6 - 9T	M8 - 12T	M8 - 16T	M10 - 19T
k1	4	5	6	7	8
m mm	2.7	2.7	3.2	3.2	4
n mm	1.8	1.8	1.8	2.3	2.3
o mm	M3	M4	M5	M6	M6
p mm	M3	M4	M5	M5	M5
Max. operating pressure bar	9	9	9	9	6
Max. total clamping force kN	4.6	18	45	52	55
Weight kg	1.15	3.6	10.3	18.5	30.4
Cylinder volume (double stroke) cm ³	38	180	600	900	1760
Closing time s	0.1	0.25	0.5	0.6	1.1
Clamping repeatability mm	0.01	0.01	0.02	0.03	0.03

KZS-PG - large jaw stroke



APPLICATION

Optimally suited for use in 3-, 4- and 5-axis machining centers as well as on all common zero-point clamping systems

TYPE

Pneumatically actuated centering vice with large jaw stroke. Optionally with inductive sensors. 2-jaws version.

CUSTOMER BENEFITS

- ③ Jaw stroke expanded by up to 20% for a larger clamping range
- ③ Highest clamping forces of up to 55 kN, optimal results and process reliability through precision wedge hook system
- ③ Optimized lubrication system for constantly high clamping forces
- ③ Compact design with reduced interfering contours for optimum workpiece accessibility, ideal working space utilization and optimum chip flow
- ③ Sturdy and low-backlash jaw guides for high repeatability

TECHNICAL FEATURES

- Jaws with cross tenon and serration

KZS-PG = power-operated, centering, vice, pneumatically, large jaw stroke



The power-operated centering vices are also available with integrated stroke sensor, which serves for clamping control and ensures optimum process monitoring and thus optimal process reliability.



KZS-PG - large jaw stroke

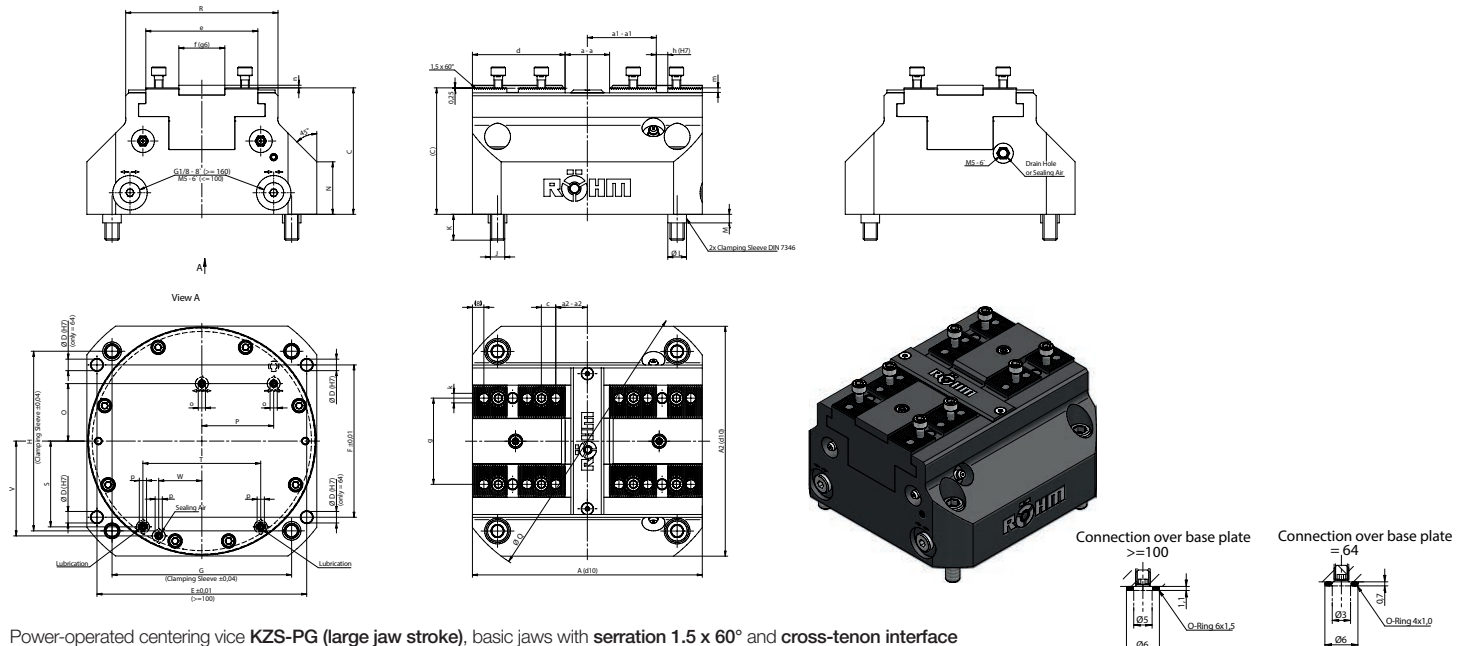

Power-operated centering vice **KZS-PG (large jaw stroke)**, basic jaws with serration 1.5 x 60° and cross-tenon interface

Item No.	181483	181487	181491	181495
Item No. with inductive sensors	181583 ▲	181587 ▲	181591 ▲	181595 ▲
Size	KZS-PG 100	KZS-PG 160	KZS-PG 200	KZS-PG 250
A1 mm	100	160	200	250
Jaw stroke B mm	7	9.5	12.1	17.6
C mm	69.2	82.2	90.2	98.2
D H7 mm	6 - 12T	8 - 14T	8 - 14T	10 - 20T
E±0.01 mm	90	146	184	230
F±0.01 mm	64	106	146	154
G±0.04 mm	80	125	160	200
H±0.04 mm	80	125	160	200
J mm	M8	M10	M10	M12
K mm	15	18	18	20
L mm	11	13	13	16
M mm	4.5	6	6	6
N mm	34.8	31.5	34.2	35.7 (50°)
O mm	32	40	50	64
P mm	29.5	50	65	75
Q mm	130	200	250	310
R mm	68	106	140	166
S mm	34.5	59.7	72.5	92.6
T mm	55	82	110	139.6
V mm	44	74	817.7	110.8
W mm	25.5	32	48	60
a mm	20.2 - 33	25 - 44	32 - 56.2	41 - 76.2
a1 mm	25.5 - 32.5	44.8 - 54.3	54.5 - 66.6	51.5 - 69.1
a2 mm	14.5 - 21.5	18.8 - 28.3	28.5 - 40.6	32.5 - 50.1
b mm	7.5	11.2	11.5	15
c mm	7	10	10	12
d mm	40.5	67.5	81	99
e mm	47	78	102	125
f ⁹⁶ mm	20	32	40	50
g mm	35	60	80	90
h ^{H7} mm	6	8	8	10
k	M6 - 9T	M8 - 12T	M8 - 16T	M10 - 19T
k1	5	6	7	7
m mm	2.7	3.2	3.2	4
n mm	1.8	1.8	2.3	2.3
o mm	M4	M5	M6	M6
p mm	M4	M5	M5	M5
Max. operating pressure bar	9	9	9	6
Max. total clamping force kN	8	20	24	21
Weight kg	3.65	10.5	18.9	30.4
Cylinder volume (double stroke) cm ³	180	600	900	1760
Closing time s	0.25	0.5	0.6	1.1
Clamping repeatability mm	0.01	0.02	0.03	0.03

Power-operated centering vices KZS-PG

Jaws KZS-P / KZS-PG

C 21

Soft top jaws, 2-jaw set, can be hardened serration 60° - material: 16MnCr5



Item no.	Size	Jaw length mm	Jaw height mm	Jaw width mm
166138	64	25	20	34
166140	100	42	25	55
166142	160	60	40	80
166144	200	75	45	100
166146	250	90	50	125

C 21

Soft top jaws, 2-jaw set tongue and groove, high design, material: 16MnCr5



Item no.	Size	Jaw length mm	Jaw height mm	Jaw width mm
166126	64	28,5	35	34
166128	100	47	48	55
166130	160	76	77,5	80
166132	200	96	85	100
166134	250	120	100	125

Accessories KZS-P / KZS-PG

A09 Special grease F80 for lathe chucks

For lubrication and conservation of chucking power



Item no.	Design	Contents
308555	Cartridge (DIN 1284) Ø 53.5x235mm	0,5 kg
028975	Tin	1 kg

C15 Grease gun DIN1283

Item no.	Connection	Contents of delivery
329093	M10x1	150 mm nozzle tube bent, needlepoint mouthpiece, top mouthpiece, 300 mm high pressure hose with 4 jaw hydraulics cross mouthpiece

KZS-H



APPLICATION

Optimally suited for use in 3-, 4- and 5-axis machining centers as well as on all common zero-point clamping systems

TYPE

Hydraulically actuated centering vice in standard design. Optionally with inductive sensors. 2-jaws version.

CUSTOMER BENEFITS

- ⊕ Jaw stroke expanded by up to 20% for a larger clamping range
- ⊕ Highest clamping forces of up to 55 kN, optimal results and process reliability through precision wedge hook system
- ⊕ Optimized lubrication system for constantly high clamping forces
- ⊕ Compact design with reduced interfering contours for optimum workpiece accessibility, ideal working space utilization and optimum chip flow
- ⊕ Sturdy and low-backlash jaw guides for high repeatability

TECHNICAL FEATURES

- Jaws with cross tenon and serration

KZS-H = power-operated, centering, vice, hydraulically



The power-operated centering vices are also available with integrated stroke sensor, which serves for clamping control and ensures optimum process monitoring and thus optimal process reliability.



KZS-H

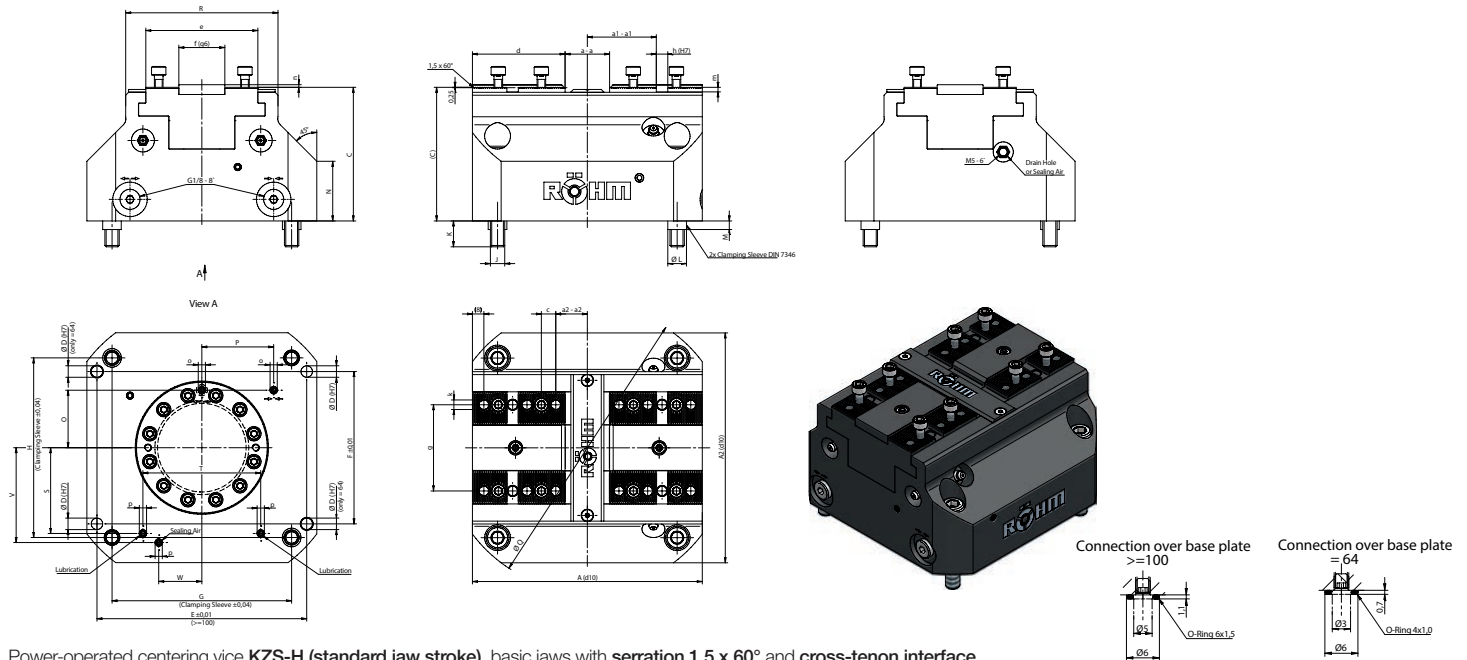

Power-operated centering vice KZS-H (standard jaw stroke), basic jaws with serration 1.5 x 60° and cross-tenon interface

Item No.	181481	181484	181488
Item No. with inductive sensors	181581 ▲	181584 ▲	181588 ▲
Size	KZS-H 64	KZS-H 100	KZS-H 160
A1 mm	64	100	160
Jaw stroke B mm	2.3	2.3	3.5
C mm	55.7	74.2	87.2
D H7 mm	4 - 7.5T	6 - 12T	8 - 14T
E±0.01 mm	36	90	146
F±0.01 mm	56	64	106
G±0.04 mm	50	80	125
H±0.04 mm	50	80	125
J mm	M6	M8	M10
K mm	12	15	18
L mm	8	11	13
M mm	4	4.5	6
N mm	31.2	39.8	36.5
O mm	17	32	40
P mm	17	29.5	50
Q mm	84	130	200
R mm	45	68	106
S mm	21.1	34.5	59.7
T mm	33.6	55	82
V mm	-27.5	44	74
W mm	0	25.5	32
a mm	12.8 - 17.4	20.4 - 25	24 - 31
a1 mm	12.9 - 15.2	25.7 - 28	44.5 - 48
a2 mm	9.9 - 12.2	14.7 - 17	18.5 - 22
b mm	4.8	5	8
c mm	5	7	10
d mm	23.3	37.5	64.5
e mm	30	47	78
f ⁹⁶ mm	14	20	32
g mm	24	35	60
h ¹⁷ mm	4	6	8
k	M4 - 7T	M6 - 9T	M8 - 12T
k1	4	5	6
m mm	2.7	2.7	3.2
n mm	1.8	1.8	1.8
o mm	M3	M4	M5
p mm	M3	M4	M5
Max. operating pressure bar	60	60	60
Max. total clamping force kN	4.5	18	45
Weight kg	1.45	4.55	13.3
Cylinder volume (double stroke) cm ³	7	30	100
Closing time s	0.4	1.1	1.6
Clamping repeatability mm	0.01	0.01	0.02

KZS-HG - large jaw stroke



APPLICATION

Optimally suited for use in 3-, 4- and 5-axis machining centers as well as on all common zero-point clamping systems

TYPE

Hydraulically actuated centering vice with large jaw stroke. Optionally with inductive sensors. 2-jaws version.

CUSTOMER BENEFITS

- ③ Jaw stroke expanded by up to 20% for a larger clamping range
- ③ Highest clamping forces of up to 55 kN, optimal results and process reliability through precision wedge hook system
- ③ Optimized lubrication system for constantly high clamping forces
- ③ Compact design with reduced interfering contours for optimum workpiece accessibility, ideal working space utilization and optimum chip flow
- ③ Sturdy and low-backlash jaw guides for high repeatability

TECHNICAL FEATURES

- Jaws with cross tenon and serration

KZS-HG = power-operated, centering, vice, hydraulically, large jaw stroke



The power-operated centering vices are also available with integrated stroke sensor, which serves for clamping control and ensures optimum process monitoring and thus optimal process reliability.



KZS-HG - large jaw stroke

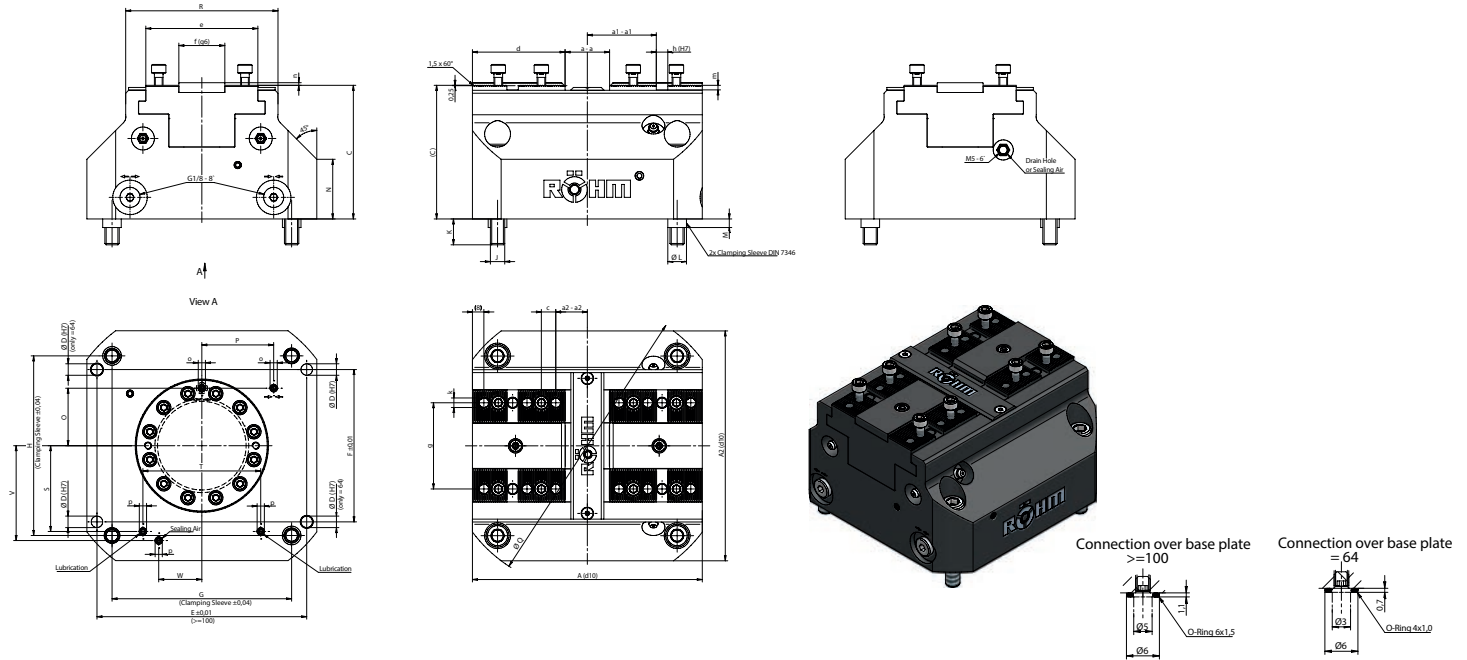

Power-operated centering vice **KZS-HG (large jaw stroke)**, basic jaws with **serration 1.5 x 60°** and **cross-tenon interface**

Item No.	181485	181489	181493	181497
Item No. with inductive sensors	181585 ▲	181589 ▲	181593 ▲	181597 ▲
Size	KZS-HG 100	KZS-HG 160	KZS-HG 200	KZS-HG 250
A1 mm	100	160	200	250
Jaw stroke B mm	7	9.5	12.1	17.6
C mm	74.2	87.2	95.2	103.2
D H7 mm	6 - 12T	8 - 14T	8 - 14T	10 - 20T
E ±0.01 mm	90	146	184	180
F ±0.01 mm	64	106	146	200
G ±0.04 mm	80	125	160	180
H ±0.04 mm	80	125	160	200
J mm	M8	M10	M10	M12
K mm	15	18	18	20
L mm	11	13	13	16
M mm	4.5	6	6	6
N mm	39.8	36.5	39.2	57.5 (50°)
O mm	32	40	50	80
P mm	29.5	50	65	45
Q mm	130	200	250	310
R mm	68	106	140	166
S mm	34.5	59.7	72.5	50
T mm	55	82	110	140
V mm	44	74	87.7	70
W mm	25.5	32	48	50
a mm	20.2 - 33	25 - 44	32 - 56.2	41 - 76.2
a1 mm	25.5 - 32.5	44.8 - 54.3	54.5 - 66.6	51.5 - 69.1
a2 mm	14.5 - 21.5	18.8 - 28.3	28.5 - 40.6	32.5 - 50.1
b mm	7.5	11.2	11.5	15
c mm	7	10	10	12
d mm	40.5	67.5	81	99
e mm	47	78	102	125
f ⁹⁶ mm	20	32	40	50
g mm	35	60	80	90
h ¹¹⁷ mm	6	8	8	10
k	M6 - 9T	M8 - 12T	M8 - 16T	M10 - 19T
k1	5	6	7	7
m mm	2.7	3.2	3.2	4
n mm	1.8	1.8	2.3	2.3
o mm	M4	M5	M6	M6
p mm	M4	M5	M5	M5
Max. operating pressure bar	120	120	60	60
Max. total clamping force kN	16	40	50	50
Weight kg	4.65	13.5	22.9	35.2
Cylinder volume (double stroke) cm ³	30	100	300	420
Closing time s	1.1	1.6	2.1	3
Clamping repeatability mm	0.01	0.02	0.03	0.03

Jaws KZS-H / KZS-HG

C 21

Soft top jaws, 2-jaw set, can be hardened serration 60° - material: 16MnCr5



Item no.	Size	Jaw length mm	Jaw height mm	Jaw width mm
166138	64	25	20	34
166140	100	42	25	55
166142	160	60	40	80
166144	200	75	45	100
166146	250	90	50	125

C 21

Soft top jaws, 2-jaw set tongue and groove, high design, material: 16MnCr5



Item no.	Size	Jaw length mm	Jaw height mm	Jaw width mm
166126	64	28,5	35	34
166128	100	47	48	55
166130	160	76	77,5	80
166132	200	96	85	100
166134	250	120	100	125

Accessories KZS-H / KZS-HG

A09 Special grease F80 for lathe chucks

For lubrication and conservation of chucking power



Item no.	Design	Contents
308555	Cartridge (DIN 1284) Ø 53.5x235mm	0,5 kg
028975	Tin	1 kg

C15 Grease gun DIN1283

Item no.	Connection	Contents of delivery
329093	M10x1	150 mm nozzle tube bent, needlepoint mouthpiece, top mouthpiece, 300 mm high pressure hose with 4 jaw hydraulics cross mouthpiece



APPLICATION

For stationary centric clamping of workpieces on milling machines or machining centers.

TYPE

Clamping system consisting of a 3-jaw chuck, including an integrated pneumatic cylinder.
Serration 90°.

CUSTOMER BENEFITS

- ⊕ Compact design
- ⊕ Large variety of applications is possible by using different clamping jaws
- ⊕ Centric clamping of round and angular workpieces
- ⊕ High repeatability thanks to sturdy chuck construction and constant clamping force at same pressure
- ⊕ Purge air connection possible to prevent contamination

TECHNICAL FEATURES

- Wedge hook system with pneumatic actuation
- Clamping force can be regulated by changing the pressure

Note:

Hydraulic actuation on request

SSP = stationary, power chuck, pneumatically



Stationary power chuck SSP

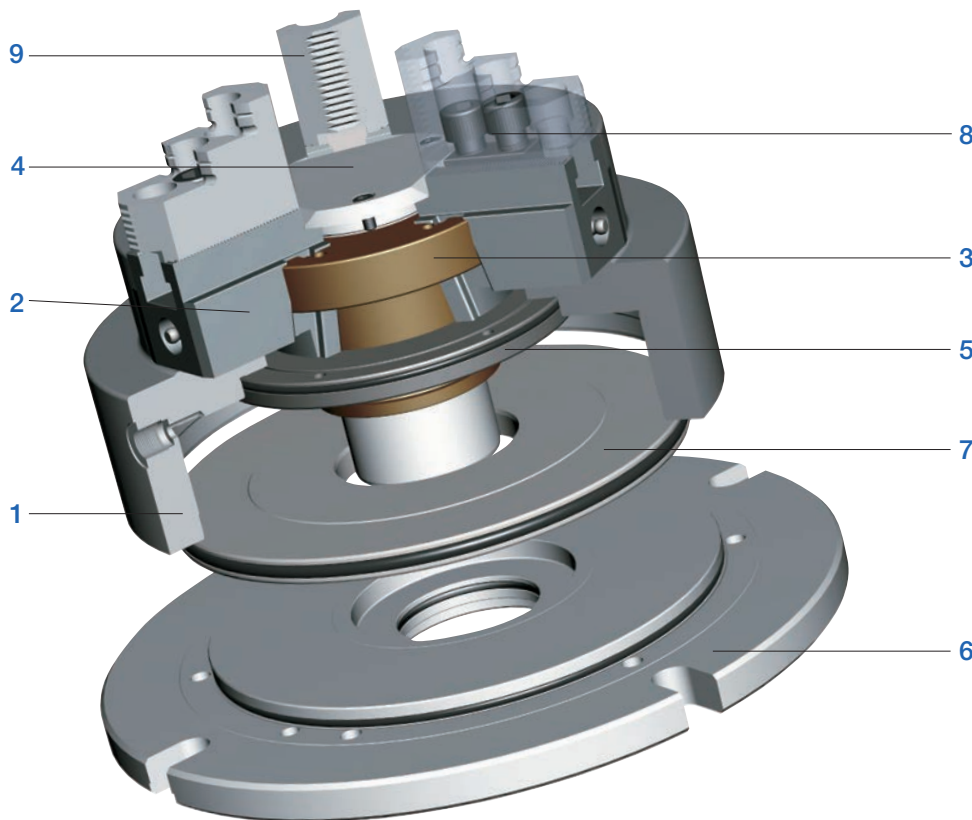

Components:

1. Body
2. Base jaw
3. Piston
4. Protective bushing
5. Intermediate disc
6. Mount
7. Piston disc
8. T-nut
9. Top jaws

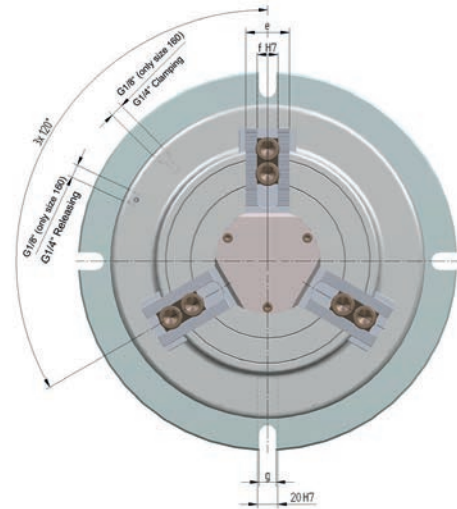
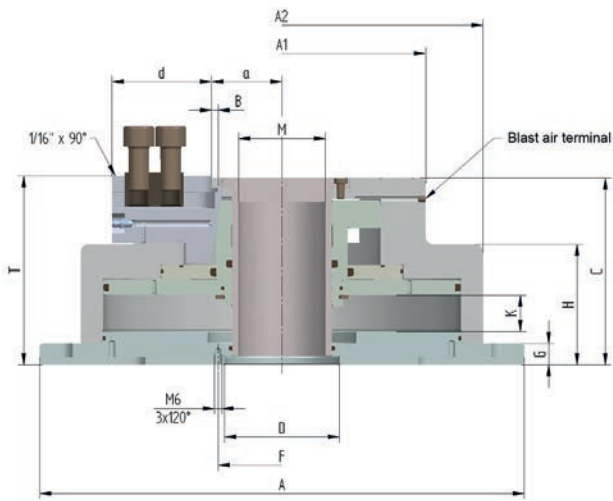

C 15
Stationary power chucks SSP, air operated 3-jaw chucks, without through-hole, serration 1/16" x 90°

Item No.	161505	161506▲	161507▲	161508
Size	160	200	250	315
Number of jaws	3	3	3	3
A mm	260	320	380	415
A1 mm	178	205	255	320
A2 mm	210	255	315	350
Jaw travel B mm	4,2	4,2	5	5
C mm	130,5	134	146	156,5
Mount D ^{#6}	55	70	90	110
D	M8	M12	M16	M16
F mm	65	80	100	120
G mm	15	17	17	21,5
H mm	84,5	86	94	104,5
Wedge stroke K mm	24	23,8	28,4	28,4
Possible through-hole M mm	38	52	68	90
T mm	131,5	135,5	147,5	158
U	M8	M12	M16	M16
a min.	31,8	41,2	50	61,5
a max.	36	45,4	55	66,5
c mm	15	19	25	25
d mm	54,5	62	78	99
e mm	32	36	44	44
f ^{#7} mm	12	17	21	21
g mm	13	17	17	17
Piston area cm ²	209	323	532	654
Min. operating pressure bar	2	2	2	2
Max. operating pressure bar	8	8	8	8
Max. total clamping force at working pressure - External clamping kN	36 (bei 6 bar)	55 (bei 6 bar)	90 (bei 6 bar)	111 (bei 6 bar)
Max. total clamping force at working pressure - Internal clamping kN	38 (bei 6 bar)	60 (bei 5 bar)	96 (bei 6 bar)	118 (bei 6 bar)
Weight without jaws approx. kg	25	34	54	65

Jaws SSP

C 21

Reversible top jaws, 3-jaw set, hardened serration 90° - material: 16MnCr5

Item no.	Size	Jaw length mm	Jaw height mm	Jaw width mm	Serration
046404	160	56	37,5	26	1/16"x 90°
118522	200	75	49	36	1/16"x 90°
046414	250/315	103,5	58	50	1/16"x 90°

Additionally or later applied, hardened jaws must be ground out in the chuck.

C 21

Soft top jaws, 3-jaw set, can be hardened serration 90° - material: 16MnCr5

Item no.	Size	Jaw length mm	Jaw height mm	Jaw width mm	Serration
046403	160	55	38	26,5	1/16"x 90°
133153	200	75	53	36,5	1/16"x 90°
133154	250	95	54,5	45	1/16"x 90°

C 21

Claw-type jaws, 1 piece, hardened serration 90° - width of the groove 12

Item no.	Size	Jaw length mm	Jaw height mm	Claw length mm	Serration
144320	160	66	38	52	1/16"x 90°
144321	160	56	38	34	1/16"x 90°
144322	160	66	38	25	1/16"x 90°

C 21

Claw-type jaws, 1 piece, hardened serration 90° - width of the groove 17

Item no.	Size	Jaw length mm	Jaw height mm	Claw length mm	Serration
137031	200	67	45	53	1/16"x 90°
137032	200	65	45	46	1/16"x 90°
137039	200	55	45	40	1/16"x 90°
137034	200	50	45	31	1/16"x 90°
137035	200	55	45	27	1/16"x 90°
137036	200	65	45	19	1/16"x 90°
137037	200	65	45	26	1/16"x 90°
137038	200	55	45	24	1/16"x 90°
137033	200	55	45	39	1/16"x 90°

C 21

Claw-type jaws, 1 piece, hardened serration 90° - width of the groove 21

Item no.	Size	Jaw length mm	Jaw height mm	Claw length mm	Serration
137041	250/315	95	50	80	1/16"x 90°
137042	250/315	75	50	60	1/16"x 90°
137043	250/315	60	50	43	1/16"x 90°
137044	250/315	70	50	37	1/16"x 90°
137045	250/315	95	50	25	1/16"x 90°
137046	250/315	80	50	30	1/16"x 90°

Accessories SSP

C 15
Extended T-nuts With screw

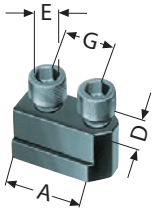

Item no.	Chuck Size	Con- tents of delivery	D mm	E	G mm
1305178 ▲	160	piece	12	M8x25	2x15
1305179	200	piece	17	M12x30	19
1305180 ▲	250/315	piece	21	M16x35	25

Jaw dimensions SSP

Reversible top jaws UB, hardened, serration 90°

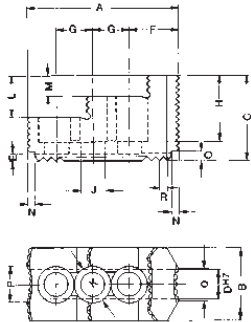

Chuck size	160	200	250/315
Type	538-02	538-04	538-05
Item no. 3-jaw set	046404	118522	046414
A	56	75	103,5
B	26	36	50
C	37,5	49	58
DH7	12	17	21
E	3,5	5	5
F	14	21,5	33,5
G	15	19	25
H	29	37,5	45
J	8,4	13	17
K	13,5	19	25
L	20	24	28
M	10	12	14
N	4	6	6
O	4	7,5	6,5
P	5	18	24,5
Q	5	7	22,5
R	1/16" x 90°	1/16" x 90°	1/16" x 90°
Weight/jaw kg	0,170	0,460	1,130

Soft top jaws AB, Serration 90°

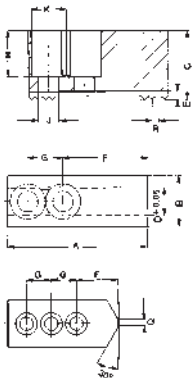

Chuck size	160	200	250/315
Type	538-02	538-03	538-05
Item no. 3-jaw set	046403	133152	133154
A	55	66,7	95
B	26,5	36,5	45
C	38	53	54,5
D	12	17	21
E	3,5	5	5
F	31	36	55
G	15	19	25
H	28	43	42,5
J	8,4	13	17
K	13,5	19	25
Q	-	-	-
R	1/16" x 90°	1/16" x 90°	1/16" x 90°
Weight/jaw kg	0,330	0,700	1,400

F-senso chuck clamping force measuring device

APPLICATION

Suitable for 3 jaw chucks and vices.

The F-senso clamping force measurement device enables you to check the clamping force as well as the rotational speed of your clamping tools.
The centrifugal behavior is thus directly related to the accompanying software evaluated.

TYPE

- ⊕ Broad clamping range of 75 - 175 mm through interchangeable pressure pins
- ⊕ Broad measuring range from 0 - 100 kN per jaw
- ⊕ Dynamic clamping force measurement under rotation up to 8250 rpm
- ⊕ Real-time data transmission via Bluetooth to included tablet
- ⊕ Delivered in the practical hard-shell case

TECHNICAL FEATURES

- No additional attachments necessary on the machine
- Easy positioning through positioning aid
- Automated switch-off



Video F-senso chuck

ADVANTAGES AT A GLANCE

- ⊕ Direct output of the centrifugal force behavior through combined measurement of clamping force and speed
- ⊕ Flexibility through large clamping and measuring range
- ⊕ Easy handling without additional set-ups on the machine

F-senso chuck

Included in the scope of delivery:

- Base with foam insert
- Clamping force measuring head, F-senso chuck
- Pressure bolts in lengths 5 mm, 15 mm, 25 mm and 30 mm
- Pressure bolt elongation in length 25 mm
- Practical insertion aid
- Tablet PC with pre-installed measuring and evaluation program



C 15

Clamping force measurement device F-senso chuck

Item No.	179800
Measuring range / Clamping force kN	2 jaws: 0 - 200; 3 jaws: 0 - 300
Measuring range / Rotation speed min-1	0 - 8250
Accuracy	Force <0.5% / Rotation speed ±10 rpm within the complete measuring range
Clamping Ø mm	75 - 175
Dimensions (base unit)	Ø 75/80 x 130

EASYLOCK zero point clamping system

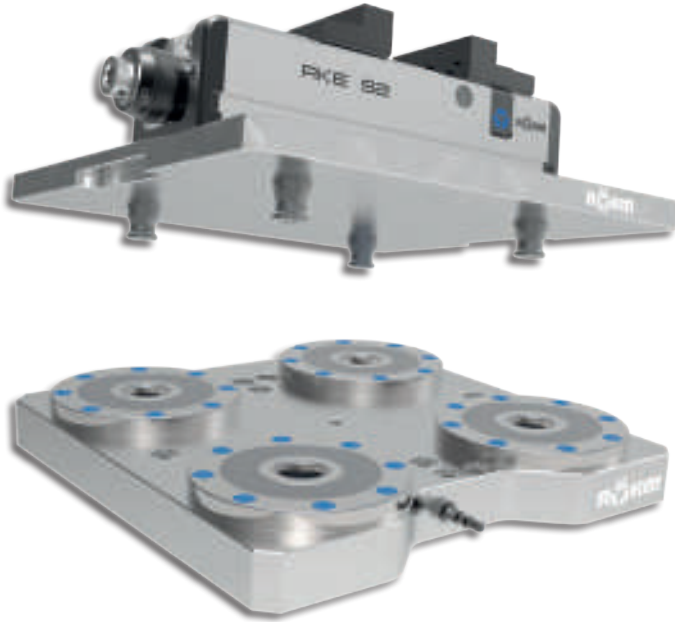

Palletising systems such as the EASYLOCK zero point clamping system from RÖHM achieve a considerable productivity increase. This modular system meets the requirements of customer-specific solutions with the best-possible utilisation of machine capacity. Although the machine tool had to stop for the set-up time until now, the workpiece can now be clamped and positioned on the pallet outside the machine tool. The set-up time is now only limited to loading and unloading the pallet, which happens in seconds. If multiple manufacturing processes are necessary for machining, then the pallet including the workpiece can be used without zero point loss. Due to the robust and rust-resistant construction, EASYLOCK zero point clamping can be used throughout, starting with machining up to the measuring machines.

THE BENEFITS AT A GLANCE

INCREASED PRODUCTIVITY

- ⊕ Free machine capacity through reduction of set-up time by up to 90%
- ⊕ Very rapid change of workpiece and clamping fixtures on tilt-free clamping and positioning with long insert

HIGH PRECISION

- ⊕ Repeat accuracy of < 0.005 mm thanks to precision balls
- ⊕ Positive-locking self-inhibition unaffected by tensile and lateral forces

HIGHEST MODULARITY

- ⊕ Modular base carrier design variants for maximum flexibility
- ⊕ Flexible extension options

The pin system

HOW IT WORKS

With the RÖHM EASYLOCK zero point clamping system, the clamping pin is the interface between the machine table and the workpiece or fixture. The exact positioning guarantees secure clamping. At the same time the resulting machining forces are transferred via the clamping pin to the pressure cup. The high-precision pressure cups of the EASYLOCK system ensure an absolutely secure hold of the workpiece or fixture. The high locking and holding forces make the system suitable for all kinds of use.



Machining with EASYLOCK?

EASYLOCK is ideally suited to all machining processes like grinding, milling, drilling and measuring.

What is meant by holding force?

Holding force is the force at which the pallet still rests securely on the clamping system. This force must not be exceeded during machining.

What is meant by repeat accuracy?

The repeat accuracy gives the tolerance range for the recorded workpiece references when the workpiece is removed and subsequently reclamped. The repeat accuracy of the EASYLOCK system is around < 0.005 mm.

EASYLOCK zero point clamping system

REDUCED SET-UP TIMES BY UP TO 90%

Without palletising system



With EASYLOCK zero point clamping system

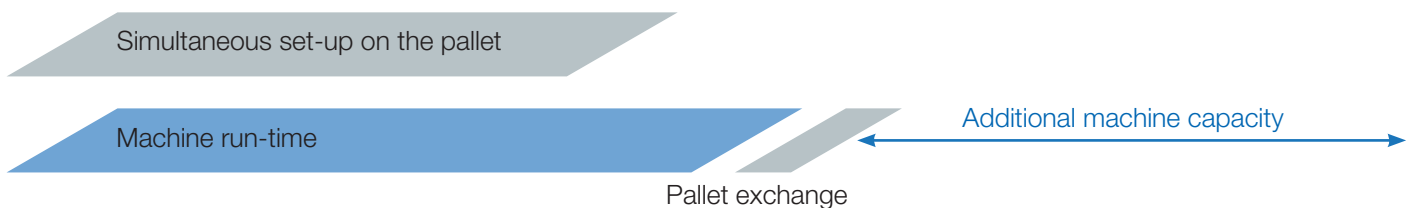

Power-operated clamping devices

To ensure safe operation of power-operated clamping devices, particularly of chucks, on heavy-duty lathes with high speeds certain criteria must be observed:

1. When mounting the power chuck and the clamping cylinder on the lathe, the following safety requirements must be met:
 - 1.1 The machine spindle may only start when the clamping pressure has been built up in the actuating cylinder and the clamping has been carried out in the permissible working area.
 - 1.2 Unclamping may only be possible when the machine spindle has completely stopped.
 - 1.3 In case of a clamping energy failure, the workpiece must be firmly clamped until the spindle is completely stopped. (The Röhm safety cylinders meet this requirement.)
 - 1.4 In case of a current failure and upon return of the current supply the actual control position may not be changed.
 - 1.5 In case of a clamping energy failure the machine spindle must be stopped by a signal.
2. The safety instructions given in the respective operation manual must be precisely followed.
3. After having mounted the chuck and before starting the operation, the function of the chuck must be checked.

Two important points are:

3.1 Clamping force

The clamping force ($\pm 15\%$) stated for the clamping device must be reached at max. actuating force/pressure.

3.2 Stroke control

A safety range must be provided for the stroke of the clamping piston in the front and rear end position. The machine spindle may only start after the clamping piston has crossed the safety range.

Only limit switches meeting the requirements for safety limit switches in accordance with VDE 0113/12.73 section 7.1.3 may be used for monitoring the clamping path.

4. If the max. speed of the lathe exceeds the max. speed of the clamping device or clamping cylinder, the machine must be equipped with a speed limitation device.
5. When the clamping device has been changed, the stroke control must be adjusted to the new condition.
6. When calculating the required clamping force for machining a workpiece, the centrifugal force of the clamping jaws must be considered.
7. A reliable operation of the power chuck can only be guaranteed when the maintenance instructions contained in the instruction manual are precisely followed.

In particular the following points must be observed:

- 7.1 For the lubrication only the lubricants recommended in the operation manual shall be used. (An unsuitable lubricant can reduce the clamping force by more than 50%).
- 7.2 The lubrication must reach all surfaces to be lubricated.
(At the narrow fits of the mounting parts a high pressure is required for pressing-in the lubricant. For those purpose a pressure gun must be used).
- 7.3 In order to distribute the grease evenly, actuate the clamping piston several times to its end positions, repeat the lubrication and then check the clamping force.

Power-operated clamping devices

8. Before restarting a serial machining operation and in between the maintenance intervals the clamping force should be checked by means of a load cell. "Only regular checks ensure optimum reliability".
9. It is recommended to move the clamping piston several times to its end positions after 500 clamping strokes at the latest. (In this way any lubricant pushed away will be returned to the pressure surfaces. The pressure force is thus maintained for a longer period of time.)
10. When using special clamping jaws the following instructions must be observed:
 - 10.1 The clamping jaws should be designed in such a way that their weight and height is as low as possible. The clamping point should as possible be as close to the frontside of the chuck. (Clamping points at a larger distance may cause a higher surface pressure in the jaw guiding mechanism and may thus reduce the clamping force considerably.)
 - 10.2 In case the special jaws are for constructional reasons wider and/or higher than the step jaws assigned to the clamping device, the resulting higher centrifugal forces must be considered when calculating the required clamping pressure and the rated speed.

For calculating the rated speed for a certain machining task the following formula is to be applied:

$$n_{\max.} = \sqrt{\frac{F_{sp0} - F_{spz}}{m \cdot r_c \cdot a}} \cdot \frac{30}{\pi}$$

F_{sp0} = initial clamping force with the chuck at standstill (N)

F_{spz} = required clamping force with the chuck at standstill for a certain machining task (N)

n_{max.} = max. admissible speed (min 1)

m = mass of the entire jaw unit (kg) (base and top jaw)

r_c = center of gravity radius of the entire jaw unit (m)

a = number of jaws

- 10.3 Welded jaws should not be used. If required, the welding seams must be checked as to their centrifugal and clamping force capacity.
- 10.4 The mounting screws must be arranged in such a way that the highest possible useful moment is reached.
11. The max. speed may only be used at max. applied actuating force and with properly functioning chucks.
12. In case of high speeds the chucks may only be used below a protective hood with sufficiently large dimensions.
13. For power chucks with a jaw quick-change feature internal to the chuck a safety device is required which prevents the machine spindle from rotating when the clamping jaws are released.
14. After a collision the clamping device must be checked for fissures before being used again.
15. Worn or damaged jaw fixing bolts must be replaced. Only use bolts of quality 12.9.

Power-operated clamping devices

Determining the required gripping force of a power chuck and the corresponding operating power

- I) Calculating the gripping force F_{Spz} (without considering the effects of angular speed) required for the job (machining operation).
- II) Determining the chuck's initial gripping force F_{Sp0} with spindle stationary (taking into account the centrifugal forces of the jaws).
- III) Determining the operating power required to provide the initial gripping force F_{Sp0} .

Definition of gripping force

Progress in machining techniques has made it necessary for safety reasons not only to determine the **necessary gripping force** but also to know and consider its change with increasing angular speed.

The forces and moments generated by the machining operation must be properly absorbed and transmitted by the chuck. The chuck accomplishes this task mainly by **producing a gripping force**:

This gripping force is the arithmetic sum of the radial forces exerted on the workpiece by the jaws. The initial gripping force F_{Sp0} produced when the chuck is stationary can be measured at any time and is therefore control-lable. (Denoted by 'total gripping force' in the gripping force / operating power diagrams).

The figures given in the catalogue refer only to chucks that are fully and correctly lubricated and in a properly serviced condition. Many factors act on the clamping point during any machining operation. A precise specification of these factors in the form of universally applicable tables is not possible in this context.

In most cases it is sufficient in practice to use a simplified formula containing the fundamental determining factors (crude determination).

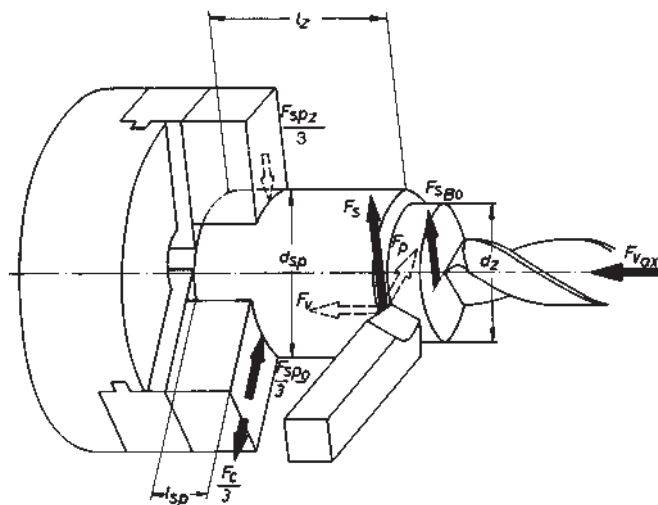

- F_s = Main cutting force on radially applied tool
- F_{sBo} = Cutting force on axially applied tool (drill)
- F_{vax} = Feeding force on axially applied tool
- F_{Spz} = Required total gripping force (without considering the effects of angular speed)
- F_c = Centrifugal force of the jaws
= Loss of gripping force (see gripping force/speed diagram of each chuck Typee)
- F_{Sp0} = (Total) initial gripping force with the chuck stationary
- l_z = Distance between machining and clamping points
- d_z = Machining diameter
- d_{sp} = Chucking diameter
- l_{sp} = Chucking length

Power-operated clamping devices

A Turning

l) Calculating the required gripping force F_{spz}

The gripping force required depends on the Type of work to be performed.

The cutting force on the turning tool has three basic components:

Main cutting force F_s - feeding force F_v - passive force (static force) F_p .

During turning, the feeding force F_v and the passive force (static force) F_p are mainly absorbed by the jaw faces in contact with the seated workpiece. The remaining main cutting force produces a moment ($F_s \times dz/2$) which must be absorbed by the chuck and transmitted by friction at the clamping point.

The moment produced by the main cutting force during turning determines the gripping force required:

$$F_{spz} = \frac{F_s \cdot S_z}{\mu_{sp}} \cdot \frac{d_z}{d_{sp}} \quad (1)$$

where:

F_{spz} = gripping force required for a specific job with the chuck stationary

F_s = main cutting force

chucking ratio $\frac{d_z}{d_{sp}} = \frac{\text{machining diameter}}{\text{chucking}}$

μ_{sp} = cucking coefficient (friction between jaw and workpiece)

S_z = safety factor

The feeding force and passive components, F_v and F_p , are not included in this formula. If necessary for extreme conditions, they are included in the safety factor S_z .

The **main cutting force F_s** is calculated from feed, depth of cut and material.

where:

s = feed, mm/rev.

t = depth of cut, mm

k_c = specific cutting force, kN/mm²

$$F_s = s \cdot t \cdot k_c \quad (2)$$

The product $s \times t$ (feed.depth of cut) = chip cross-section (can be obtained from Table 1).

Determining the chip cross section [mm²] Table 1

Feed (mm)	Depth of cut t (mm)									
	2	3	4	5	6	7	8	9	10	12
0,16				0,8	0,96	1,12	1,28	1,44	1,6	1,92
0,20			0,8	1,0	1,2	1,4	1,6	1,8	2,0	2,4
0,25		0,75	1,0	1,25	1,5	1,75	2,0	2,25	2,5	3,0
0,32	0,64	0,96	1,28	1,6	1,96	2,24	2,56	2,88	3,2	3,84
0,40	0,8	1,2	1,6	2,0	2,4	2,8	3,2	3,6	4,0	4,8
0,50	1,0	1,5	2,0	2,5	3,0	3,5	4,0	4,5	5,0	6,0
0,63	1,26	1,89	2,52	3,15	3,78	4,41	5,04	5,67	6,3	7,56
0,80	1,6	2,4	3,2	4,0	4,8	5,6	6,4	7,2	8,0	9,6
1,0	2,0	3,0	4,0	5,0	6,0	7,0	8,0	9,0	10,0	12,0
1,25	2,5	3,75	5,0	6,25	7,5	8,75	10,0	11,25	12,5	15,0
1,60	3,2	4,8	6,4	8,0	9,6	11,2	12,8	14,4	16,0	19,2

The specific cutting force k_c as a function of feed can be obtained from Table 2.

Power-operated clamping devices

Specific cutting force k_c [kN/mm²] Table 2

Specific cutting force k_c at feed s and a setting angle of 45°								
Material		Strength B kN/mm ²	Feed s [mm]					
			0,16	0,25	0,4	0,63	1,0	1,6
Steels	St 42	sino 0,50	2,60	2,40	2,20	2,05	1,90	1,80
	St 50	0,52	3,50	3,10	2,75	2,45	2,15	1,95
	St 60	0,62	3,05	2,80	2,60	2,40	2,20	2,05
	C 45	0,67						
	C 60	0,77						
	St 70	0,72	4,35	3,80	3,30	2,90	2,50	2,20
	18 CrNi 6	0,63						
	42 CrMo 4	0,73	4,35	3,90	3,45	3,10	2,75	2,45
	16MnCr5	0,77	3,75	3,30	2,95	2,60	2,30	2,05
	Mn, CrNi	0,85-1,00	3,70	3,40	3,10	2,80	2,55	2,35
	Mn-austenitic st.		5,40	4,90	4,40	4,00	3,60	3,30
Cast iron materials	St 42	0,30-0,50	2,30	2,10	1,95	1,80	1,70	1,60
	St 42	0,50-0,70	2,55	2,35	2,20	2,05	1,90	1,80
	St 42	HB 2,00	1,50	1,35	1,20	1,10	1,00	0,90
	St 42	HB 2,00-2,50	2,05	1,80	1,60	1,45	1,30	1,15
NE-ferrous metals	Cast bronze		2,55	2,35	2,20	2,05	1,90	1,80
	Gunmetal		1,10	1,00	0,90	0,80	0,70	0,65
	Brass	HB 0,80-1,20	1,20	1,10	1,00	0,90	0,80	0,75
	Cast alumin.	0,30-0,422,60	1,10	1,00	0,90	0,80	0,70	0,65

The chucking ratio $\frac{d_z}{d_{sp}}$ can either be determined from the specified working conditions or obtained from Table 3.

Chucking ratio Table 3

Feed-Ø d_{sp} (mm)	Depth of cut-Ø d_z [mm]														
	20	40	60	80	100	150	200	250	300	350	400	500	600	700	800
20	1,0	2,0	3,0	4,0											
40	0,5	1,0	1,5	2,0	2,5	3,8									
60	0,33	0,67	1,0	1,3	1,7	2,5	3,3	4,2							
80	0,25	0,5	0,75	1,0	1,3	1,9	2,5	3,1	3,8	4,4					
100	0,2	0,4	0,6	0,8	1,0	1,5	2,0	2,5	3,0	3,5	4,0				
150	0,13	0,27	0,4	0,53	0,67	1,0	1,3	1,7	2,0	1,3	2,7	3,3	4,0		
200		0,2	0,3	0,4	0,5	0,75	1,0	1,3	1,5	1,8	2,0	2,5	3,0	3,5	4,0
250		0,16	0,24	0,32	0,4	0,6	0,8	1,0	1,2	1,4	1,6	2,0	2,4	2,8	3,2
300			0,2	0,27	0,33	0,5	0,67	0,83	1,0	1,2	1,3	1,7	2,0	2,3	2,7
350			0,17	0,23	0,29	0,43	0,57	0,72	0,86	1,0	1,1	1,4	1,7	2,0	2,3
400				0,2	0,25	0,38	0,5	0,62	0,75	0,87	1,0	1,3	1,5	1,8	2,0
500				0,16	0,2	0,3	0,4	0,5	0,6	0,7	0,8	1,0	1,2	1,4	1,6
600					0,17	0,25	0,33	0,42	0,5	0,58	0,67	0,83	1,0	1,2	1,3
700						0,21	0,29	0,36	0,43	0,5	0,57	0,71	0,86	1,0	1,1
800						0,19	0,25	0,31	0,37	0,44	0,5	0,62	0,75	0,87	1,0

The chucking coefficient μ_{sp} accounts for the friction existing between the gripping surface of the jaws and the workpiece in the zone of contact. It is influenced by

- the pattern of the gripping surfaces of the jaws
- the surface quality of the workpiece
- the material.

The chucking coefficient can be obtained from Table 4.

Note:

Forces are more efficiently transmitted by a snug fit than by edge or saddle-Type seats.

Chucking coefficient μ_{sp} for steel parts Table 4

Surface workpiece	Smooth	Gripping surface of jaws Diamond style	Serrated
smooth machine finish ground	0,07	0,12	0,20
rough to medium machine finish	0,10	0,20	0,35
unmachined	0,15	0,30	0,45
Corrections:		Al, alloy = 0,95 Brass = 0,90 Gray cast iron = 0,80	

Power-operated clamping devices

Safety factor S_z

The magnitude of the safety factor S_z depends on the degree of accuracy with which the influencing parameters, such as load, chucking coefficient etc., can be determined and on the degree of safety required. It should be ≥ 2 wherever possible.

Safety factor S_z (approximate)

Table 5

Influencing parameters	Safety factor S_z	
	New chucks	Older chucks serviced regularly
a) overhung chucking $l_z \leq d_{sp}$ b) no radial support from tailstock c) tool applied radially d) no axial seating of workpiece against jaws e) ratio: chucking length to distance between cutting and clamping points $\frac{l_z}{l_{sp}} \leq 3$	≥ 2.0	≥ 2.4
$\frac{l_z}{l_{sp}} \geq 3 \leq 6$	$\geq 4.0^*$	$\geq 4.8^*$

* Lower safety factors can be applied if the workpiece is supported in the tailstock or axially seated against the jaws.

Superimpositions of alternating forces are neglected because their influence is very small in comparison with the total gripping force required.

The safety factors so determined are applicable if the following requirements are met:

Chuck in perfect condition, no damage, adequately lubricated (operating instructions followed to the letter).

No allowance has been made for the following loads acting on the chuck:

- a) Unbalanced forces and moments produced by unsymmetrical workpieces
- b) Weight of workpiece

For a precise calculation of the gripping force required for a given job, use VDI Recommendation 3106. Available from: Beuth-Verlag GmbH, Kamekestraße 8, D-50672 Köln, Germany.

II)

At high speeds, the gripping force of the rotating lathe chuck is greatly influenced by the centrifugal forces of the jaws. These forces must be taken into account when determining the initial gripping force F_{spo}

The applicable formula is:

$$F_{SPO} = S_{SP} \times (F_{SPZ} \pm F_C)$$

The + sign applies to external gripping.
The - sign applies to internal gripping.

Power-operated clamping devices

Where:

F_c = experimentally determined total centrifugal force of the chuck jaws obtained from the gripping forcespeed diagram. The gripping force curves refer to the hard, stepped jaws of the chuck.

S_{sp} = safety factor for the initial gripping force in accordance with VDI Recommendation 3106 $\geq 1,5$

If extremely heavy top jaws (special jaws) are used, the centrifugal forces F_c can be calculated using VDI Recommendation 3106.

III)
The operating power bears a given relationship to the total gripping force, depending on the Typee of chuck employed. The values for the operating power can be obtained from the gripping force/operating power diagram.

In special cases where the centrifugal forces of the jaws are very high in comparison with the initial gripping force and power chucks with standard top jaws cannot be used, certain operations can be done with aluminium top jaws of special strength.

Calculation (example)

Having:

1. Workpiece and machining data:		
Material		= C 45
Chucking diameter: (roughed)	d_{sp}	= 60 mm Ø
Machining diameter:	d_z	= 20 mm Ø
Feed:	s	= 0,5 mm
Depth of cut:	t	= 5 mm
Distance cutting/clamp. points:	l_z	= 50 mm
Speed:	n	= 3000 min ⁻¹

2. Chuck data:

KFD 200 power chuck

Jaws with diamond style gripping surface Condition of chuck: new (no special influencing parameters)

External gripping with UB-538-04 top jaws at mid-position of gripping range.

Find:

- 1) Required gripping force F_{spz} = total gripping force required (without the effect of angular speed)
- 2) Initial gripping force F_{spo} = (total) initial gripping force with the chuck stationary
- 3) Operating power

Power-operated clamping devices

Solution

1) Main cutting force (Formula 2)

$s \cdot t$ = from Table 1
 k_C = from Table 2

$$F_s = s \cdot t \cdot k_C = 0,5 \cdot 5 \cdot 2,50 = 6,25 \text{ kN}$$

2) Required gripping force (Formula 1)

$$F_{spz} = \frac{F_s \cdot S_z}{\mu_{sp}} \cdot \frac{d_z}{d_{sp}}$$

$$= \frac{6,25 \text{ kN} \cdot 2,0 \cdot 0,33}{0,20} \approx 21,00 \text{ kN}$$

Safety factor S_z = from Table 5
Chucking coeff. μ_{sp} = from Table 4

Chucking ratio $\frac{d_z}{d_{sp}}$ = from Table 3

- Obtain the loss of the gripping force from the gripping force speed diagram for KFD 200. At a speed of 3000 rpm: $F_c = 18 \text{ kN}$. See diagram below.
- Initial gripping force $F_{sp0} = S_{sp} \cdot (F_{spz} + F_c)$ (Formula 3) = $1,5 \cdot (21 \text{ kN} + 18 \text{ kN}) = 58,50 \text{ kN}$
 S_{sp} determined in accordance with VDI Recommendation 3106 F_c obtained from diagram below
- Obtain operating power from "gripping force/operating power" diagram for KFD 200. For a gripping force of 58,50 kN the operating power is ~ 29,00 kW (next page)

Gripping force/speed diagram for KFD 3-jaw chucks

upper curve:
min. centrifugal force of top jaw



lower curve:
max. centrifugal force of top jaw

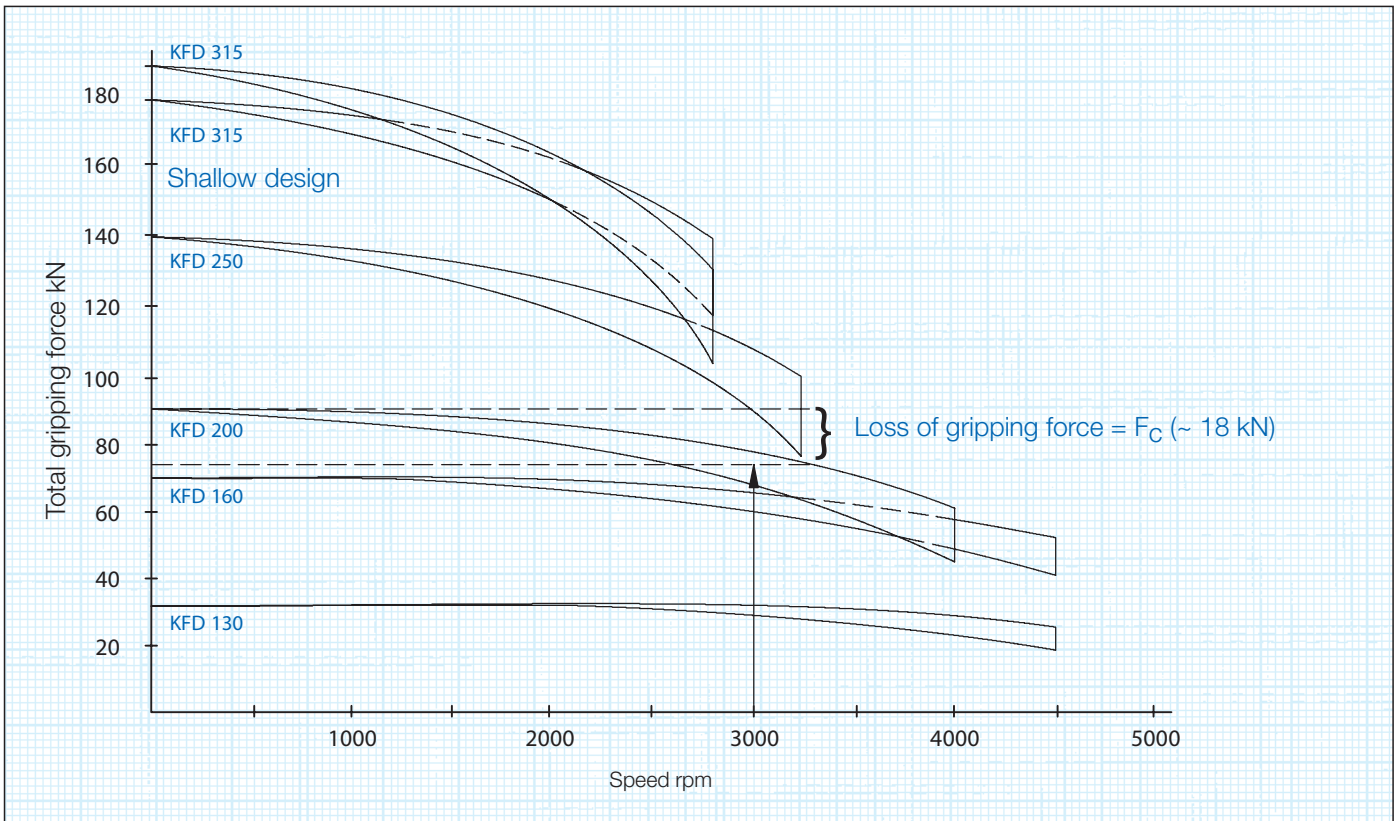

Power-operated clamping devices

Power-operated clamping devices

Gripping force/operating power diagram KFD 3-jaw chuck

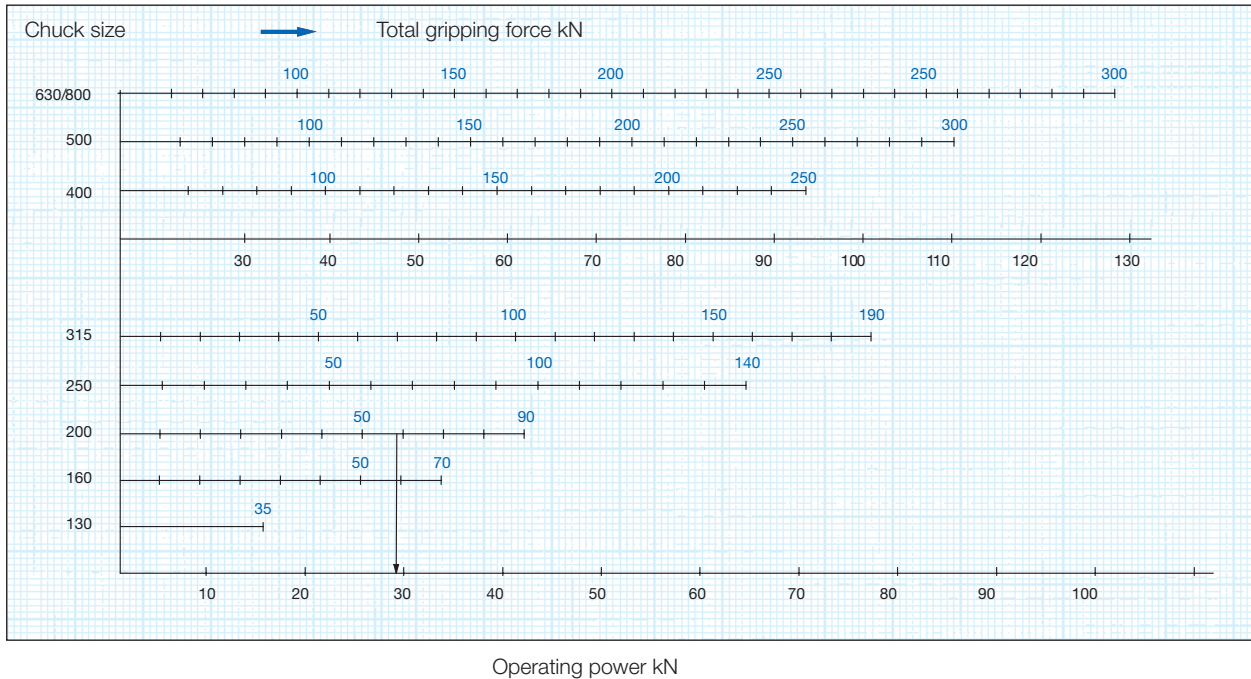

B. Drilling

1. Drilling in solid material (Top lip twist drill, point angle $\geq 120^\circ$)

I)

The gripping force required is determined by the Type of work to be performed. The calculation described below applies to freely chucked work, i. e. workpieces which are not axially seated against the jaws. In this situation the components F_{sBo} (cutting force) and F_{vax} (feeding force) acting on the workpiece give the resultant F_R to determine the gripping force.

The cutting force F_{sBo} can be calculated from

$$F_{sBo} = s \cdot t \cdot k_c \quad (4)$$

where:

s = feed, mm/rev.

t = depth of cut, mm = $\frac{\text{drill diameter}}{2}$

k_c = specific cutting force kN/mm^2

The feeding force F_{vax} bears a given relationship to the cutting force and can be directly obtained from Table 6.

Feeding force F_{vax}
Table 6

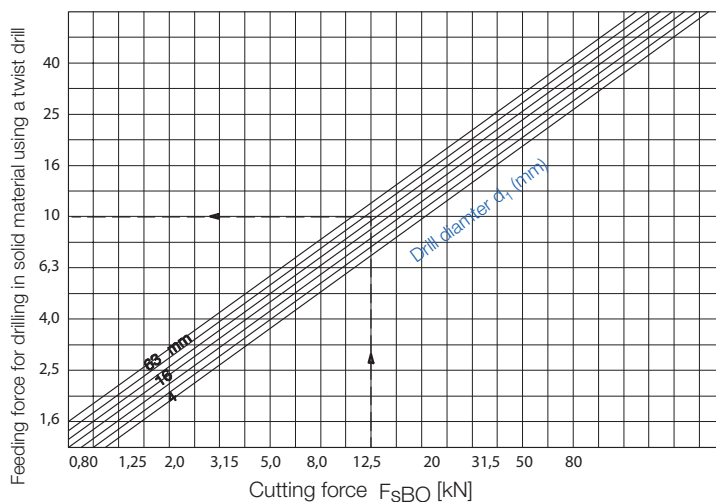

Power-operated clamping devices

Power-operated clamping devices

The two components F_{SBo} and F_{vax} give the resultant force F_R

$$F_R = \sqrt{F_{SBo}^2 + F_{vax}^2}$$

The amount of the resultant force F_R can be obtained directly from Table 7. Intermediate values will have to be determined by interpolation.

Resultant force F_R KN

Table 7

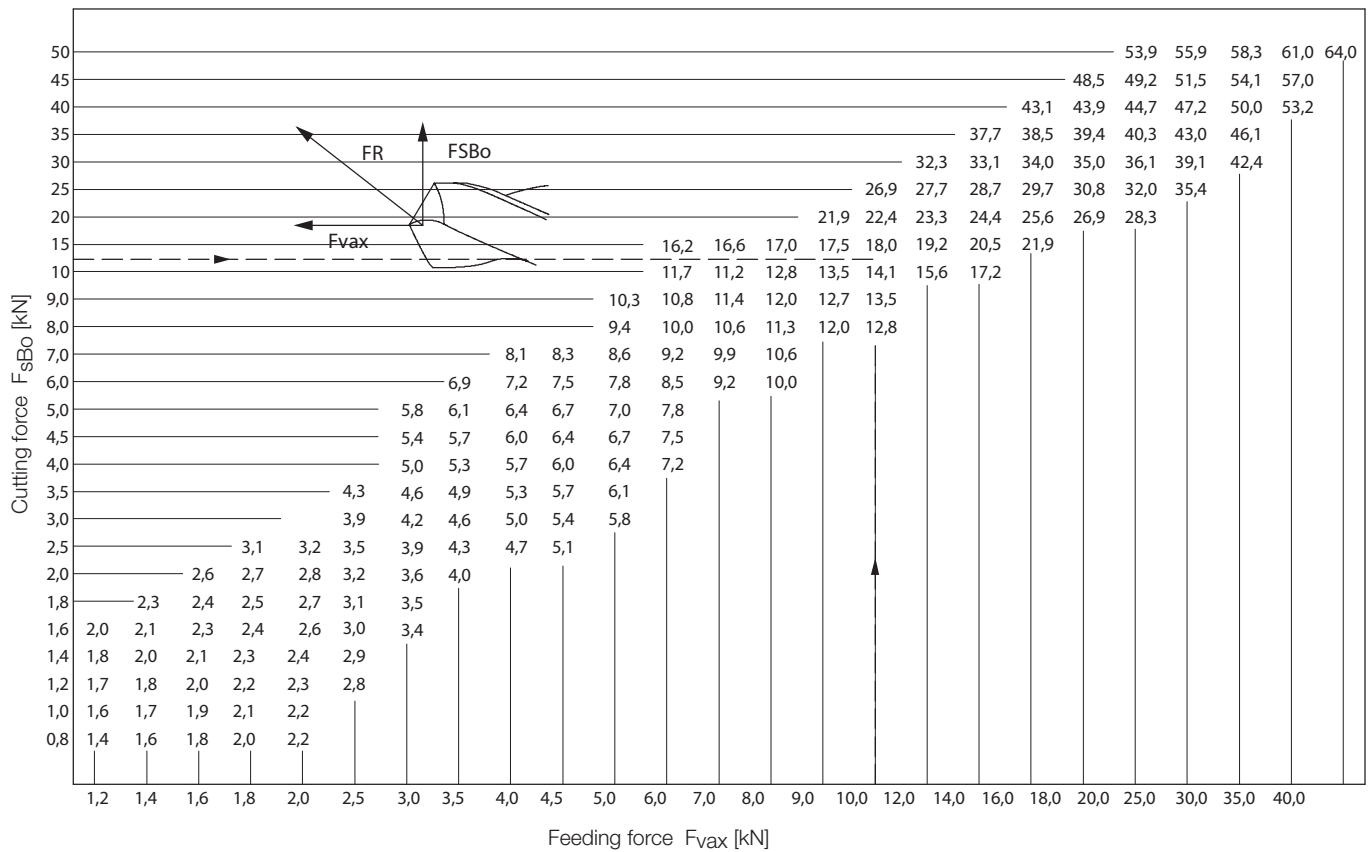

Place resultant force F_R for drilling in solid material in the known formula for determining the required gripping force F_{spz} :

$$F_{spz} = \frac{F_R \cdot S_z}{\mu_{sp}} \cdot \frac{d_z}{d_{sp}}$$

where:

F_{spz} = gripping force required for a given job with the chuck stationary.

F_R = resultant force of cutting force and feeding force

Chucking ratio $\frac{d_z}{d_{sp}} = \frac{\text{cutting dia.}}{\text{chucking dia}}$ where $d_z = \frac{\text{drill dia.}}{2}$

μ_{sp} = chucking coefficient (friction between jaw and workiece)

S_z = safety factor

II and III

Continue the calculation - from determination of the initial gripping force F_{spo} to determination of operating power and the pressure required - exactly as described in Section A) Turning, II) and III).

Power-operated clamping devices

Calculation (example):

Having:

1. Workpiece and machining data.

Material	=	C 45
Chucking dia. d_{sp} (roughed)	=	60 mm
Drill dia. (in solid mat.)	=	30 mm
Feed s	=	0,3 mm
Depth of cut t	=	15 mm
Speed n	=	200 min ⁻¹

2. Chuck data

Power chuck KFD 200
 Jaws with diamond style gripping surface
 External gripping with UB 538-04 top jaws at mid position of gripping range
 Chuck in new condition (no special influencing parameters)

Find:

1. Required gripping force F_{spz}
2. Initial gripping force F_{spo}
3. Operating power

Solution:

1. Cutting force (Formula 4)

$F_{sBo} = s \cdot t \cdot kc = 0,3 \cdot 15 \cdot 2,70 = 12,10 \text{ kN}$
 $s \cdot t$ from Table 1 (or calculated)
 k_C from Table 2

2. Required gripping force

$$F_{spz} = \frac{F_R \cdot S_z}{\mu_{sp}} \cdot \frac{d_z}{d_{sp}} = \frac{15,70 \cdot 2,0}{0,2} \cdot 0,25 = 39,25 \text{ kN}$$

Obtain resultant force F_R from Table 7 (after first obtaining F)

Chucking ratio $\frac{d_z}{d_{sp}}$ from Table 3 (or calculated).

3. Check if any effective centrifugal forces act on the jaws at a speed of $n = 200 \text{ min}^{-1}$.
 As this is not the case in this example, we have:
4. Initial gripping force $F_{spo} = S_{sp} \cdot F_{spz} = 1,5 \cdot 39,25 \text{ kN}$
 S_{sp} from VDI recommendation 3106 = 59,00 kN
5. Obtain operating power from the "gripping force/operating power" diagram for KFD 200.
 For a gripping force of 59,00 kN the operating power is 29 kN
6. For boring (using a boring cutter) the calculation described under "A. Turning" applies analogously.



The headquarters: our main plant in Sontheim/Brenz

The RÖHM main plant is located in Sontheim/Brenz. In this ultra-modern production facility comprising 41,000 m² optimum conditions have been achieved in order to solve the extensive range of discerning construction and production tasks making the company even better, faster and more efficient in the future.



Sontheim/Brenz

Sontheim | All national and international activities are planned and coordinated at the administrative headquarters in Sontheim. Thanks to the excellent infrastructure and transport routes, this location is ideal for a company relying on perfect product quality as well as maximum flexibility. Furthermore, the region around Sontheim offers another key basis for the success of our company: it is rich in quality awareness and motivated employees with the result that we are ideally prepared for the challenges of the future. The main plant uniquely unites mass production, serial production and customised individual production under a single roof.

Key locations for the company: Dillingen and St. Georgen

Such strong growth on the part of the RÖHM Group is also obviously associated with higher requirements on development and production capacities. The demands of today and tomorrow can be complied with the two facilities in Dillingen and St. Georgen.



Dillingen/Danube



St. Georgen

Plant Dillingen/Danube | This branch plant in Dillingen was put into operation by the RÖHM Group as early as 1953. Thanks to extremely positive development, the plant is subject to constant expansion and modernisation. For this reason, new modern production facilities were built in 1982 and 1991. In 2007 RÖHM built a new production hall for two portal turning and milling machines. This enables machining of workpieces up to 4 metres in length which will secure a leading market position for RÖHM in the future. More than 300 employees are primarily involved in engineering and manufacturing lathechucks, machine vices and special clamping equipment for turning and milling machinery as well as for machining centres.

Engineering and sales department St. Georgen | Apart from standard mandrels, tailor-made solutions for a wide variety of requirements are also manufactured here in this small but accomplished high-tech forge. RÖHM retains mechanical or power-operated mandrels, sliding jaw mandrels and hydraulic mandrels for its customers for tensioning workpieces in drill holes or interior contours.

Always close to our customers. With locations all around the world.



Customer orientation at RÖHM has less to do with marketing than with attitude. We consider customer proximity as an intensive dialogue with our partners as well as direct presence on key international markets.



Your contacts at RÖHM

Manufacturing and distribution bases

Germany:

RÖHM GmbH
Heinrich-Röhm-Straße 50
89567 Sontheim/Brenz
Tel 0049 73 25 – 16 0
Fax 0049 73 25 – 16 510
info@roehm.biz
www.roehm.biz

RÖHM GmbH

Röhmstraße 6
89407 Dillingen
Tel 0049 90 71 – 5 08-0
Fax 0049 90 71 – 5 08-174
infodlg@roehm.biz

RÖHM GmbH

Feldbergstr. 5
78112 St. Georgen
Tel 0049 – 77 24 – 94 68 12
Fax 0049 – 77 24 – 51 89
Mobil 0152 – 22 88 70 50
stg.info@roehm.biz

Brazil:

RÖHM IND. E COM. DE
FERRAMENTAS DE FIXAÇÃO LTDA.
Rod. Raposo Tavares, Km 14 - Bloco A
2º andar - sala 2 - CEP 05576-100
São Paulo
Tel 0055 – 11 – 37 32 22 22
Fax 0055 – 11 – 37 35 30 97
vendas@roh.com.br
www.br.roehm.biz

China:

ROEHM China Co., Ltd.
Room 702, Building 24,
No. 518 Xinzhuan Road,
Songjiang District,
201612 Shanghai
Tel 0086 – 21 – 37 70 53 95
Fax 0086 – 21 – 37 70 53 76
roehmcn@roehm.biz

Czech Republic:

RÖHM SLOVAKIA S.R.O.
Partizanska 73
95701 Banovce nad Bebravou
Slovakia
Tel 00421 – 3 87 60 02 22
Fax 00421 – 3 87 60 02 24
Mobil 00421 – 902 556 777
info@roehm.sk

France:

RÖHM S. A. R. L.
325 rue Paul Langevin
BP 90204
F-60744 Saint Maximin cedex
Tel 0033 – 344 64 10 00
Fax 0033 – 344 64 00 68
fr.roehm@roehm.biz
www.rohm.fr

Great Britain:

ROHM (Great Britain) LTD.
Unit 12 the ashway centre
Elm crescent Kingston-upon-Thames
Surrey KT 2 6 HH
Tel 0044 – 20 85 49 66 47
Fax 0044 – 20 85 41 17 83
rohmgbr@roehm.biz
www.uk.roehm.biz

Italy:

RÖHM Italia S. R. L.
Via Reiss Romoli 17-19
20019 Settimo Milanese (MI)
Palazzo Rothenberger
Tel 0039 – 02 – 92 10 35 31
Fax 0039 – 02 – 92 10 17 53
rohmitalia@roehm.biz
www.roehm-italia.it

Mexico:

RÖHM Products México S. de R.L.
Emilio Garza Meléndez #6606
Col. Campestre Mederos
Monterrey, N.L., México, C.P. 64970
Tel 0052 81 – 9627 – 0686
info@roh-products.com

Switzerland:

RÖHM Spanntechnik AG
Feldstraße 39, 3360 Herzogenbuchsee
Tel 0041 – 629 56 30 20
Fax 0041 – 629 56 30 29
roehmch@roehm-spanntechnik.ch
www.ch.roehm.biz

Singapore:

RÖHM Asia Pacific Pte. Ltd.
8 Ubi Road 2
#07-10 Zervex
Singapore 408538
Tel 0065 – 64 43 77 48
Mobil 0065 – 83 28 89 80
info@sg.roehm.biz
www.sg.roehm.biz

Slovakia:

RÖHM SLOVAKIA S.R.O.
Partizanska 73
95701 Banovce nad Bebravou
Slovakia
Tel 00421 – 3 87 60 02 22
Fax 00421 – 3 87 60 02 24
Mobil 00421 – 9 14 12 29 32
info@roehm.sk

Spain:

RÖHM Iberica S. A.
C/Rejas, No. 9 Nave 11 D
28022 Madrid
Tel 0034 – 91 – 3 13 57 90
Fax 0034 – 91 – 3 13 57 93
rohmiiberica@roehm.biz
www.roehm-iberica.es

USA:

ROHM Products of America
2500 Northlake Drive
30024 Suwanee, GA
Tel 001 – 770 – 963 – 8440
Fax 001 – 770 – 963 – 8407
rohmusa@roehm.biz
www.us.roehm.biz

Poland:

RÖHM Polska Sp. z o.o.
Aleje Jerozolimskie 424A
05-800 Pruszków
Tel 0048 – 22 – 759 – 59 90
Fax 0048 – 22 – 759 – 59 99
roehmpolska@roehm.biz

Portugal:

RÖHM Iberica S. A.
C/Rejas, No. 9 Nave 11 D
28022 Madrid
Tel 0035 1926 85 38 81
es.pjfermandes@roehm.com
www.roehm-iberica.es

Hungary:

RÖHM Hungaria Kft.
Gyár u. 2. (BITEP Ipari Park)
H-2040 Budaörs
Tel 0036 – 209 – 324 597
jozsef.alker@roehm.biz

Presence on all continents from A for Australia to V for Vietnam. You can receive the contact information of our worldwide representations easily through www.roehm.biz.



Sales Agents in Germany

Baden-Wuerttemberg:

Thomas Haas
Tel 0 77 25 / 91 48 95
Mobile 0152 / 22 88 71 20
thomas.haas@roehm.biz

Dominik Gotthelf
Mobile 0152 / 22 88 70 93
dominik.gotthelf@roehm.biz

Richard Sedlak
Tel 0 70 21 / 94 98 970
Mobile 0152 / 22 88 70 30
richard.sedlak@roehm.biz

Baden-Wuerttemberg / Rhineland-Palatinate / Saarland:

Michael Schmitz
Tel 00 33 3 88 72 04 03
Mobile 0152 / 22 88 70 18
michael.schmitz@roehm.biz

Baden-Wuerttemberg / Bavaria:

Dirk Gaarz
Mobil 0152 / 22 88 71 16
dirk.gaarz@roehm.biz

Bavaria:

Jan Birkholz
Mobile 0152 / 22 88 70 14
jan.birkholz@roehm.biz

Gerhard Häutle
Tel 0 90 71 / 7 29 93 22
Mobile 0152 / 22 88 70 15
gerhard.haeutle@roehm.biz

Christian Heigl
Mobile 0152 / 22 88 70 26
christian.heigl@roehm.biz

Bavaria / Thuringia:

Steffen Blatz
Mobile 0152 / 22 88 70 16
steffen.blatz@roehm.biz

North Rhine-Westphalia / Rhineland-Palatinate

Ralf Schnichels
Tel 0 21 52 / 8 97 35 47
Mobile 0152 / 22 88 70 25
ralf.schnichels@roehm.biz

North Rhine-Westphalia:

Friedhelm Schneider
Tel 0 27 62 / 49 07 28
Mobile 0152 / 22 88 70 17
friedhelm.schneider@roehm.biz

North Rhine-Westphalia / Lower Saxony

Thorsten Nolte
Tel 0 27 21 / 12 01 82
Mobile 0152 / 22 88 70 31
thorsten.nolte@roehm.biz

Lower Saxony / Saxony

Susanne Bormann
Mobile 0152 / 22 88 70 88
susanne.bormann@roehm.biz

Berlin, Mecklenburg-Western Pomerania, Brandenburg, Saxony-Anhalt:

Hendrik Seifert
Tel 0 30 / 70 07 24 59
Mobile 0152 / 22 88 70 32
hendrik.seifert@roehm.biz

Hesse:

Klaus Dieter Hofmann
Tel 0 64 06 / 90 67 40
Mobile 0152 / 22 88 70 29
k.d.hofmann@roehm.biz

Hamburg / Bremen / Schleswig-Holstein / Lower Saxony:

Willi Phillip Hövermann
Mobile 0152 / 22 88 71 48
WilliPhillip.Hoevermann@roehm.biz

Agents worldwide

Algeria:

RÖHM S.A.R.L.
325, rue Paul Langevin
60740 St. Maximin, FRANCE
Tel 0033 / 344 64 10 00
Fax 0033 / 34 64 00 68
fr.roehm@roehm.biz
www.rohm.fr

Argentina:

Himaq S.R.L.,
Venezuela 3652,
1603 Villa Martelli
Prov. Buenos Aires
Tel 00 541 / 147 093 505,
Fax 00 541 / 147 093 472
himaq@himaq.com.ar

Australia:

RÖHM Asia Pacific Pte. Ltd.
8 Ubi Road 2
#07-10 Zervex
Singapore 408538
Tel 0065 – 64 43 77 48
Mobil 0065 – 83 28 89 80
info@sg.roehm.biz
www.sg.roehm.biz

FISHER LAMCO PTY LTD

Tel 0061 1300 838 572
mark.hughes@fisherlamco.com.au

Austria:

Richard Schörkhuber
Lichtenhof 2 b
8511 St. Stefan ob Stainz
Tel 00 43 / 34 63 / 8 15 10
Fax 00 43 / 34 63 / 8 15 60
Mobil 00 43 / 664 / 9 23 77 10
richard.schoerkhuber@roehm.biz

Schachermayer GmbH,

Schachermayer Str. 2
Postfach 3000, 4021 Linz
Tel 00 43 / 732 / 65 99-0
Fax 00 43 / 732 / 65 99 14 44
maschinenmetall@schachermayer.at

Lackner u. Urnitsch GmbH

Bahnhofgürtel 37, 8020 Graz
Tel 00 43 / 316 / 71 14 80-0
Fax 00 43 / 316 / 71 14 80 39
lackner@urnitsch.at

Haberkorn Ulmer GmbH

Hohe Brücke, 6961 Wolfurt
Tel 00 43 / 55 74 / 69 5-0
Fax 00 43 / 55 74 / 69 5-99
nfo.wolfurt@haberkorn.com

Metzler GmbH u. Co. KG

Oberer Paspelsweg 6-8, 6830 Rankweil
Tel. 00 43 / 55 22 / 7 79 63 - 0
Fax 00 43 / 55 22 / 7 79 63 - 6
office@metzler.at

Belarus:

RÖHM GmbH
Heinrich-Röhm-Straße 50
89567 Sontheim (Germany)
Tel 0049 73 25 – 16 0
info@roehm.ru
www.roehm.ru

Belgium:

RÖHM S.A.R.L.
325, rue Paul Langevin
60740 St. Maximin, FRANCE
Tel 0032 495 72 73 99
Fax 0032 42 86 69 48
frederik.hamels@roehm.biz
www.rohm.fr

BELTRACY

Bergensesteenweg 189
1600 Sint-Pieters-Leeuw
BELGIUM
Tel. 00 32 / 25 43 68 90
Fax 00 32 / 25 38 59 10
info@beltracy.be
www.beltracy.be

Canada:

RÖHM Products of America
2500 Northlake Drive, 30024 Suwanee, GA
Tel 001 – 770 - 963 - 8440
Fax 001 – 770 - 963 - 8407
rohmusa@roehm.biz
www.us.roehm.biz

Chile:

Robert Kralemann
SERVICOMP Ltda.
Av. Departamental 1595
La Florida - Santiago
Tel 00 56 / 2 / 8 89 47 00
rkralemann@gmail.com

Colombia:

RÖHM IND. E COM. DE
FERRAMENTAS DE FIXAÇÃO LTDA.
Rod. Raposo Tavares, Km 14 - Bloco A
2º andar - sala 2 - CEP 05576-100
São Paulo
Tel 0055 – 11 – 37 32 22 22
Fax 0055 – 11 – 37 35 30 97
vendas@rohm.com.br
www.br.roehm.biz

Costa Rica:

RÖHM IND. E COM. DE
FERRAMENTAS DE FIXAÇÃO LTDA.
Rod. Raposo Tavares, Km 14 - Bloco A
2º andar - sala 2 - CEP 05576-100
São Paulo
Tel 0055 – 11 – 37 32 22 22
Fax 0055 – 11 – 37 35 30 97
vendas@rohm.com.br
www.br.roehm.biz

Croatia:

PFEIFER - TTI D.O.O.
40000 Cakovec, Croatia
Tel 00 385-9/ 83 03 52 2
Fax 00 385-1/ 36 39 53 0
marijan.pfeifer@pfeifer-tti.hr

Denmark:

Ryttergaard Tools A/S
Falkevej 13
3400 Hillerød
Dänemark
+45 36 41 22 66
info@ryttergaard.com

Ecuador:

RÖHM IND. E COM. DE
FERRAMENTAS DE FIXAÇÃO LTDA.
Rod. Raposo Tavares, Km 14 - Bloco A
2º andar - sala 2 - CEP 05576-100
São Paulo
Tel 0055 – 11 – 37 32 22 22
Fax 0055 – 11 – 37 35 30 97
vendas@rohm.com.br
www.br.roehm.biz

Egypt:

Dirk Jaegemann Trade Agency
GmbH&Co.KG
28279 Bremen
Tel 0049 / 42 18 39 21 30
Fax 00 49 / 42 18 39 89 21
info@djta.de

Finland:

Teräskonttori Oy,
Muuntotie 3,
1510 Vantaa
Tel 00 358 / 10 219 22 00
Fax 00 358 / 10 219 22 45
info@teraskonttori.fi

Oy Interfii Ltd.

Teollisuuskatu 35-39 LH4
20520 Turku, Y-tunnus 2374026-3
Tel 00 358 / 2 01 47 45 00
Fax 00 358 / 2 01 47 45 01
info@interfii.com

Greece:

K.S.PAPADOPOULOS & CO
Ethnikis Antistaseos Str. 7-A
55134 Thessaloniki - Greece
Tel 0030 2310 488758
Fax 0030 2310 488753
stefanos@agent.com.gr
ntinos@agent.com.gr

India:

RÖHM Asia Pacific Pte. Ltd.
8 Ubi Road 2
#07-10 Zervex
Singapore 408538
Tel 0065 – 64 43 77 48
Mobil 0065 – 83 28 89 80
info@sg.roehm.biz
www.sg.roehm.biz

Indonesia:

RÖHM Asia Pacific Pte. Ltd.
8 Ubi Road 2
#07-10 Zervex
Singapore 408538
Tel 0065 – 64 43 77 48
Mobil 0065 – 83 28 89 80
info@sg.roehm.biz
www.sg.roehm.biz

PT. Gemantara Tooling Service Indonesia

Jl. Raya Bekasi Km. 21
Pulogadung Trade Centre (PTC) Blok 8A/B
Jakarta 13920 - Indonesia
Tel. +62 21 46834110
Mobile +62 811 9593027
kris@group.gts.co.id
www.gts.co.id

PT. SOMAGEDE INDONESIA

Komplek Griya Inti Sentosa
Jl. Griya Agung No. 3
Sunter Agung, Jakarta 14350 - Indonesia
Tel. +62 21 6410730
avi@somagede.com
www.somagede.com

Iran:

Sakht Abzar Pars Co. (SAP)

No. 19/4 Saeb Tabrizi St.,
North Abbas Shirazi Ave,
Molla Sadra Ave., Tehran post code 19917
Tel. 00 98 / 21 / 88 03 18 88
Fax 00 98 / 21 / 88 03 77 33
sales@sap-iran.com

Ireland:

RÖHM (Great Britain) LTD.

Unit 12 the ashway centre
Elm crescent Kingston-upon-Thames
Surrey KT 2 6 HH
Tel 0044 - 20 85 49 66 47
Fax 0044 - 20 85 41 17 83
rohmbg@roehm.biz
www.uk.roehm.biz

Iceland:

Fossberg Ltd.
Dugguvogi 6, 104 Reykjavik
Tel. 00 354 / 57 57 606
E-mail: fossberg@fossberg.is

Israel:

ETMOS Tool Distributing Co. Ltd.

34 HAHOFER ST., 5811702 Holon
Tel. 00 972 - 3 / 55 81 933
Fax 00 972 - 3 / 55 81 934
etmos@etmos.co.il

Japan:

RÖHM Asia Pacific Pte. Ltd.

8 Ubi Road 2
#07-10 Zervex
Singapore 408538
Tel 0065 – 64 43 77 48
Mobil 0065 – 83 28 89 80
info@sg.roehm.biz
www.sg.roehm.biz

Takeda Trade Co., Ltd.

NAKANOSHIMA DAI-BUILDING 603, 3-3-23,
NAKANOSHIMA, KITA-KU
530-6106 OSAKA
Tel. 00 81 3 6806 0757
hata@takeda-trade.co.jp

Luxemburg:

RÖHM S.A.R.L.
325 rue Paul Langevin
60740 St. Maximin, FRANCE
Tel 00 33 / 3 44 64 10 00
Fax 00 33 / 3 44 64 00 68
fr.roehm@roehm.biz

Malaysia:

RÖHM Asia Pacific Pte. Ltd.

8 Ubi Road 2
#07-10 Zervex
Singapore 408538
Tel 0065 – 64 43 77 48
Mobil 0065 – 83 28 89 80
info@sg.roehm.biz
www.sg.roehm.biz

KS Precision Tools (M) SDN. BHD.

A1-01-05, 1st Floor, Jalan SR 1/9
Taman Serdang Raya, Section 9,
43300 Seri Kembangan
Selangor Darul Ehsan, Malaysia
Tel. 603-8941 7168
michael@ks-precision.com



Agents worldwide

Marocco:

RÖHM S.A.R.L.
325, rue Paul Langevin
60740 St. Maximin, FRANCE
Tel 0033 / 344 64 10 00
Fax 0033 / 34 64 00 68
fr.roehm@roehm.biz
www.rohm.fr

New Zealand:

RÖHM Asia Pacific Pte. Ltd.
8 Ubi Road 2
#07-10 Zervex
Singapore 408538
Tel 0065 – 64 43 77 48
Mobil 0065 – 83 28 89 80
info@sg.roehm.biz
www.sg.roehm.biz

Trade Tools Ltd

23 Olive Road, Penrose
PO Box 112114
Auckland 1642, New Zealand
Tel 0064 9 525 88 82
sales@tradetools.co.nz

Netherlands:

Boorwerk B.V.,
Flevolaan 52 A,
Industrieterriën Noord
1382 JZ Weesp
Tel 00 31 / 294 / 43 20 50
Fax 00 31 / 294 / 43 21 52
mail@boorwerk.nl

RÖHM S.A.R.L.

325 rue Paul Langevin
BP 90204
F-60744 Saint Maximin cedex
Tel 0033 – 344 64 10 00
Fax 0033 – 344 64 00 68
fr.roehm@roehm.biz
www.rohm.fr

Norway:

Ing. Yngve Ege A/S
Ryenstubben 5
0679 Oslo 11
Tel 00 47 / 23 24 10 00
Fax 00 47 / 23 24 1001
ege@ege.no

Peru:

RÖHM IND. E COM. DE
FERRAMENTAS DE FIXAÇÃO LTDA.
Rod. Raposo Tavares, Km 14 - Bloco A
2º andar - sala 2 - CEP 05576-100
São Paulo
Tel 0055 – 11 – 37 32 22 22
Fax 0055 – 11 – 37 35 30 97
vendas@rohm.com.br
www.br.roehm.biz

Philippines:

RÖHM Asia Pacific Pte. Ltd.
8 Ubi Road 2
#07-10 Zervex
Singapore 408538
Tel 0065 – 64 43 77 48
Mobil 0065 – 83 28 89 80
info@sg.roehm.biz
www.sg.roehm.biz

Nicklaus Machinery Corporation

1795 Malabon Street
Sta. Cruz, Manila 1014 Philippines
Tel. +63 2 7118414
Mobil +63 917 8278812
nmcservice@yahoo.com
www.nicklaus-machinery.com

Romania:

KSN Technik Srl
Str. Tabacariilor 15B/103
400139 CLUJ-NAPOCA, Romania
Tel 00 40 / 264 / 449 - 533
Fax 00 40 / 264 / 449 - 533
office@ksntechnik.ro

Russia:

RÖHM GmbH
Heinrich-Röhm-Straße 50
89567 Sontheim (Germany)
Tel 0049 73 25 – 16 0
info@roehm.biz
www.roehm.ru

Saudi Arabia, UAE, Bahrain, Kuwait, Oman, Qatar, Kazakhstan, Lebanon:

RÖHM Asia Pacific Pte. Ltd.
8 Ubi Road 2
#07-10 Zervex
Singapore 408538
Tel 0065 – 64 43 77 48
Mobil 0065 – 83 28 89 80
info@sg.roehm.biz
www.sg.roehm.biz

COBALT ME FZE

SAIF ZONE
QI-05-077/C
Sharjah, VAE
Tel. +971 5568 34422
sales@cobalt-me.com

Sweden:

Techpoint Systemteknik AB
Nyponvaegen 4
19144 Sollentuna
Tel 00 46 / 86 23 13 30
Fax 00 46 / 86 23 13 45
info@techpoint.se

Luna AB

Sandbergsvägen 3,
44180 Alingsås
Tel. 00 46 / 322 60 60 00
Fax 00 46 / 322 60 62 03
info@luna.se

Singapore:

RÖHM Asia Pacific Pte. Ltd.
8 Ubi Road 2
#07-10 Zervex
Singapore 408538
Tel 0065 – 64 43 77 48
Mobil 0065 – 83 28 89 80
info@sg.roehm.biz
www.sg.roehm.biz

GP System Singapur PTE LTD

No. 51, Bukit Batok Crescent,
#04-04/05 Unity Centre,
Singapur 658077
Tel. 00 65 / 68 61 - 26 63
Fax 00 65 / 68 61 - 35 00
enquiry@gpsystem.com

Slovenia:

B T S COMPANY TRGOVINA IN
ZASTOPANJE, D.O.O.
Bratislavka 5
1000 Ljubljana
Tel 00 38 / 6 1 584 14 40
masa.bitenc@bts-company.si

South Africa:

Supra Tooling and Accessoires (Pty) Ltd
P.O. Box 1892
1460 Boksburg, Gauteng
South Africa
Tel. 0027 6467 4284
Fax 0027 11918 5492
supratooling@mweb.co.za
www.supratooling.co.za

Tooling Promotions

P.O. Box 3989
Vanderbijlpark 1900, Gauteng
South Africa
Tel 0027 016 931 1266
Fax 0027 016 931 1269
info@toolingpromotions.co.za
www.toolingpromotions.co.za

South Korea:

RÖHM Asia Pacific Pte. Ltd.
8 Ubi Road 2
#07-10 Zervex
Singapore 408538
Tel 0065 – 64 43 77 48
Mobil 0065 – 83 28 89 80
info@sg.roehm.biz
www.sg.roehm.biz

CHEONG DO MACHINE TOOL CO., LTD.

RM A-6-103, 604-1, KURO-DONG
KURO-KU, SEOUL, KOREA
Tel + 82 2 2678 4155
cdmt@chol.com
www.cdmt.co.kr

KMC Co., Ltd.

Zip code 15090
42-404, 204, Gongdang 1-daero,
Siheung-si, Gyeonggi-do, Korea
Tel +82 31 430 67 89
chelee@naver.com
www.entkr.com

Thailand:

RÖHM Asia Pacific Pte. Ltd.
8 Ubi Road 2
#07-10 Zervex
Singapore 408538
Tel 0065 – 64 43 77 48
Mobil 0065 – 83 28 89 80
info@sg.roehm.biz
www.sg.roehm.biz

Krasstec Company Limited

1205 Rama9 Soi 55, Rama 9 Rd,
Suan Luang, Suan Luang
Bangkok 10250 Thailand
Tel 66 (0)2 732 1144
Mobile 66 (0) 81 941 0509
chaitat@krasstec.com

Tunisia:

RÖHM S.A.R.L.,
325 rue Paul Langevin
60740 St. Maximin, FRANCE
Tel. 00 33 / 3 44 64 10 00
Fax 00 33 / 3 44 64 00 68
fr.roehm@roehm.biz

Turkey:

Sintek Mühendislik Makina San.
Ve Tic. Ltd. Sti.
Tarabya Mahallesi
Yumak Sok. No: 3/A1
34457 SARIYER – İSTANBUL
Tel. 00 90 / 212 / 2 99 61 84
Fax 00 90 / 212 / 2 99 56 75
sinan.onurlu@sintekmuhendislik.com

Ukraine:

Denis Alexandrov
Official Sales Consultant Russia
on behalf of RÖHM GmbH
Tel. +7 985 110 12 34
denis.alexandrov.external@roehm.biz
www.roehm.ru

Venezuela:

RÖHM IND. E COM. DE
FERRAMENTAS DE FIXAÇÃO LTDA.
Rod. Raposo Tavares, Km 14 - Bloco A
2º andar - sala 2 - CEP 05576-100
São Paulo
Tel 0055 – 11 – 37 32 22 22
Fax 0055 – 11 – 37 35 30 97
vendas@rohm.com.br
www.br.roehm.biz

Vietnam:

RÖHM Asia Pacific Pte. Ltd.
8 Ubi Road 2
#07-10 Zervex
Singapore 408538
Tel 0065 – 64 43 77 48
Mobil 0065 – 83 28 89 80
info@sg.roehm.biz
www.sg.roehm.biz

CUONG ANH MACHINERY CO., LTD

2/27 Hoang Nhu Tiep, Bo De.
Long Bien, Hanoi, Vietnam
Hanoi Office: Suite 1005 - B. HH2B
Building, Gia Thuy Street, Long Bien
District, Hanoi, Vietnam
+ 84 24 3872 3571
Ho Chi Minh City Office:
Suite 501, No 67 Pho Quang Street, 2 Ward,
Tan Binh District, Ho Chi Minh City, Vietnam
Tel 0283 547 0769
contact@cuonganhv.com
www.cuonganhv.com

General Terms of Sale and Delivery

§ 1 Offer, conclusion of contract and contractual contents

1. Our Terms of Sale shall apply exclusively; we do not recognise contradictory terms and conditions or terms and conditions which deviate from our Terms of Sale unless we have explicitly approved their validity in writing. Our Terms of Sale shall also apply if we carry out the delivery to the buyer without reservation in the knowledge of contradictory terms and conditions of the buyer or terms and conditions which deviate from our Terms of Sale.
2. Our Terms of Sale shall only apply towards an entrepreneur within the meaning of Section 14 BGB [German Civil Code].
3. Our General Service Terms shall apply with precedence over these Terms of Sale in the respective valid version in cases, which comprise the service offer of RÖHM GmbH.
4. Our offers are always to be understood as invitatio ad offerendum and are therefore without obligation insofar as they have not explicitly been described as binding. The contract shall only be concluded with our written confirmation and in line with its contents and – if a written confirmation is missing – by the service/delivery. If a delivery/service is carried out immediately without a confirmation then the invoice shall at the same time be deemed as an order confirmation.
5. Costs for the production of drawings for special constructions are to be borne by the orderer insofar as the offer does not lead to an order for reasons, for which we are not responsible.
6. All details concerning weights, dimensions, services and technical data, which are contained in our printed material, catalogues, price lists or in other contractual documents, merely serve for purposes of information and are only binding insofar as they are explicitly described as binding.
7. We reserve the right to make construction and form changes to the object of contract insofar as no changes are made hereto, which are deemed unreasonable for the orderer.
8. The documentation consists of the compilation drawing, the BOM with marking of the parts subject to wear and tear and spare parts as well as assembly instructions upon request. Respectively in German and/or, upon request, in English. This free documentation will be supplied in a digital form. The PDF format shall apply to drawings, BOMs and texts. Any scope of documentation beyond this is liable to costs respectively requires a special agreement. The documents may not be reproduced in full or in part, not made accessible to third parties or used for any other purpose apart from that for which they were handed over to the customer without our prior written authorization.
9. The corresponding measurement methods for tests, with which certain temperatures, times and other measured or control values should apply, must be stipulated before start of delivery and recognised by both parties. If no stipulation is made the measurement methods usually applied by RÖHM shall apply, we shall provide the details thereof upon request.
10. Samples will only be supplied against payment and owing to a separately placed order.
11. Assurances, collateral agreements and amendments to the contract require a written form in order to be valid. This requirement cannot be waived orally.
12. Placed orders are irrevocable unless the supplier has approved the revocation in writing.
13. In case of export business the delivery is carried out at the conditions agreed on the order confirmation, the international regulations for the interpretation of customary contractual forms shall apply in addition (incoterms 2010 of the International Chamber of Commerce, respective valid status).
14. Our General Business Terms shall apply to the RÖHM online shop with the following supplementations:
 - a) The offer on the part of the customer is submitted binding as soon as the customer orders the products in the shopping basket by using the function „binding order“.
 - b) A purchase in the online shop is only possible if the customer actively agrees to our General Business Terms.
 - c) Mistakes and errors with regard to the goods availability, prices and other details and data excepted. Diagrams in the online shop are merely for the purpose of illustration respectively as visual aids; the description is binding.
 - d) We will inform the customer if the product ordered by the customer is temporarily or permanently not available.
15. Our „product information“, technical information leaflets as well as other product-specific publications shall apply in addition to the General Business Terms. These are always to be compiled with in their current version.

§ 2 Prices

1. In the absence of special written agreements the prices in the Federal Republic of Germany shall apply „carriage paid“ recipient plus the statutory value added tax. With export business the object of delivery shall be deemed as sold „ex works“ if nothing is determined in the contract concerning the type of sale. A processing fee of EUR 15.00 will be charged for individual orders with a goods value of less than EUR 150.00 net, a processing fee of EUR 30.00 for orders with a goods value of less than EUR 50.00 net respectively plus the applicable rate of value added tax. This shall apply to deliveries within the domestic country and overseas. At the customer's request the goods can be delivered to an alternative shipping address against a logistics fee in the amount of EUR 10.00.
2. We would like to point out that we will only carry out the shipment at the customer's request. This shall have no effect on the regulations according to Section 5.
3. We shall charge the prices valid upon conclusion of the contract, which are based on the cost factors which are valid at this time. Should these cost factors (in particular material, wages, energy, etc.) change between conclusion of the contract and the agreed delivery time then we are entitled to make a corresponding change to the prices. In case of export business the supplier is entitled to terminate the contract extraordinarily with regard to the part of the order that has not yet been completed or to adjust the prices for this accordingly in the event of a substantial devaluation in the currency, in which the order is concluded.
4. In case of conclusion ex works the goods will be conveyed at the costs and risk of the orderer. With all other consignments the provisions stipulated in the incoterms 2010, respective valid status, will apply with regard to insurance and the assumption of risks.
5. We will inform the buyer of our production quantity for parts/products, which are produced especially according to the buyer's requests. The buyer undertakes to purchase the quantities confirmed to him.
6. Excess and shortfalls in deliveries of up to 5 %, with special tools up to 10 %, at least however 2 pieces, are permitted and do not substantiate any quality defects. The respective delivery will be charged.

§ 3 Terms of payment

1. In the absence of a special agreement the payment is to be made without any deduction free paying agent within 10 days after the invoice date – also with partial deliveries.
2. In case of default of payment interest will be charged in the amount of the credit costs charged by banks, at least however interest in the amount of 9 % above the respective base lending rate of the ECB.
3. In case of export business the payments are to be made in line with the agreed terms of payment.
4. Costs of the payment transactions, in particular bank charges for overseas transfers to us, shall principally be for the expense of the customer.

§ 4 Delivery time

1. The start of the delivery deadline stated by us presumes the clarification of all technical questions. Delivery dates stated by us are – insofar as not explicitly agreed or described as binding – non-binding and shall merely represent an expected delivery date.
2. The compliance with our delivery obligation further presumes the timely and proper fulfilment of the buyer's obligations, in particular the compliance with the agreed terms of payment. The right is reserved to the plea of the unfulfilled contract. This right shall also consist of obligations from previous deliveries which have not been satisfied in full.
3. The delivery deadline shall begin with the sending of the order confirmation, however not before the provision of the documents, permit, releases, etc., which are to be procured by the orderer, as well as not before the receipt of the agreed down payment.
4. If a binding delivery date has been agreed then the supplier also has to deliver within the deadline. The delivery deadline shall have been adhered to if the object of delivery has left the plant by the time it expires or notification has been given that the object is ready for delivery, the right is reserved to the timely and correct self-delivery. If the orderer changes his order with regard to parts of the delivery then the delivery deadline shall only begin to apply new again with the confirmation of the change.
5. Force majeure, war, civil commotion, strike, lock-out or measures of authorities, no matter for what reason, which oppose a delivery, as well as deficiencies of raw materials, of transport means as well as theft – also at the sub-suppliers – shall release the supplier from the obligation to deliver within the agreed deadline. The orderer is to be notified immediately of the occurrence of the event and of the expected implications.
6. Deliveries before expiry of the delivery time and in reasonable parts are permitted.
7. The adherence to the delivery time presumes the fulfilment of the orderer's contractual obligations.
8. The regulations of Subclause 10 shall apply in the event of the delay in delivery or impossibility.

§ 5 Passing of risk and acceptance

1. The risk shall pass to the orderer by no later than with the despatch of the delivered parts also if partial deliveries are made or we have taken over other services e.g. the shipping costs or delivery to the location and installation.
2. At the orderer's request the shipment shall be insured by us against theft, damages caused by breakage, transport, fire and water and other insurable risks at his costs.
3. If the shipment is delayed as a result of circumstances, for which the orderer is responsible, then the risk shall pass to the orderer from the day upon which the goods are ready for shipment; however we are obliged to procure the insurances, which he requests, at the request and costs of the orderer.
4. Delivered objects are, even if they feature insignificant features, to be accepted by the orderer irrespective of the rights from Section 8.

§ 6 Delay in acceptance, order on call

1. If the orderer does not accept the object of contract within the deadline we are entitled to set him a reasonable final deadline, to dispose otherwise over the object after its expiry and to supply the orderer with a reasonably extended deadline. Our rights to cancel the contract under the pre-requisites of Section 326 BGB and to request damages owing to the non-fulfilment shall remain unaffected hereby. If we request damages owing to non-fulfilment we can request 40 % of the agreed price plus value added tax as compensation unless the orderer proves less damages. We reserve the right to assert higher actual damages.
2. Orders, which are confirmed by us on call, must – insofar as nothing special has been agreed – be accepted by no later than within one year from the order date. The same shall apply in case of date reservations or sustainable „on call position“. Subclause 6.1 shall apply accordingly in case the goods are not called within the stated deadline.

§ 7 Reservation of title

1. The objects of the deliveries (reserved goods) shall remain our property until the fulfilment of all claims to which we are entitled against the buyer from the business relationship. Insofar as the value of all security rights, to which we are entitled against the buyer, exceed the amount of all secured claims by more than 10 %, we will release a corresponding part of the security rights at the buyer's request.
2. During the existence of the reservation of title the buyer is prohibited from a pledge or assignment as collateral and the resale only permitted for resellers in the customary course of business and only under the condition that the reseller receives a payment from his customer or stipulates the reservation that the property shall only pass to the customer when he has satisfied his payment obligations.
3. In case of attachments, seizures or other disposals or interventions of third parties the buyer has to inform us immediately so that we can file an action according to Section 771 ZPO [German Code of Civil Procedure]. Insofar as the third party is not in the position to reimburse us the court and out-of-court costs of an action according to Section 771 ZPO, the buyer will be liable for the loss incurred to us.
4. The buyer undertakes to treat the object of purchase with due care and attention; he is in particular obliged to sufficiently insure these at the value as new at his own costs against damages caused by fire, water and theft. Insofar as maintenance and inspection work is necessary the buyer must carry this out in time at his own costs.

General Terms of Sale and Delivery

5. In case of breaches of duty by the buyer, in particular with default of payment we are entitled to cancellation and to take the goods back; the buyer is obliged to hand the goods over. The taking back of goods respectively the assertion of the reservation of title does not require any cancellation of the supplier; these acts or an attachment of the reserved goods by us shall not represent a cancellation of the contract unless we had explicitly declared this.

6. If the buyer has resold the object of purchase in the ordinary course of business then he shall hereby now already assign all claims to us in the amount of the final invoice amount (including value added tax) of our claim, to which he is entitled from the resale against his buyers or third parties, irrespective of whether the object of purchase has been resold without or after processing. The buyer shall also remain authorized to collect this claim after the assignment. Our authorization to collect the claim ourselves shall remain unaffected hereby. However, we undertake not to collect the claim as long as the buyer satisfies his payment obligations from the collected proceedings, is not in default of payment and in particular no application has been filed for the opening of insolvency proceedings or payments have been suspended. If this is however the case we can request that the buyer announces the assigned claims and their debtors to us, provides us all details which are necessary for the collection, hands over the associated documents and informs the debtors (third parties) of the assignment.

7. The processing or conversion of the object of purchase by the buyer is always carried out on our behalf. If the object of purchase is processed with other objects, which do not belong to us, then we shall acquire the co-ownership to the new object in the ratio of the value of the object of purchase (end invoice amount, including value added tax) to the other processed objects at the time of the processing. Incidentally, the same shall apply to the object produced by processing as to the object of purchase delivered under reservation.

8. If the object of purchase is inseparably mixed with other objects that do not belong to us then we shall acquire the co-ownership to the new object in the ratio of the value of the object of purchase (end invoice amount, including value added tax) to the other mixed objects at the time of the mixing. If the mixing is carried out to the extent that the object of the buyer is to be seen as the main object then it shall be deemed as agreed that the buyer assigns us the pro rata co-ownership. The buyer shall store the thus produced sole ownership or co-ownership on our behalf.

§ 8 Quality defects

We shall be liable for quality defects as follows:

1. All those parts or services are to be subsequently improved free of charge at our choice, delivered or provided new, which – irrespective of the operating duration – feature a quality defect if this cause existed already at the time when the risk was passed.
2. Claims for quality defects shall become statute-barred in 12 months. The deadline will begin with the passing of the risk (Subclause 6).
3. The buyer has to report quality defects to us immediately in writing.
4. In case of reports of defects payments of the buyer may be withheld in a scope, which is in reasonable relation to the occurred quality defects. If the defect is unjustifiably reported we are entitled to request reimbursement of the expenses incurred to us by the buyer.
5. We are first of all always to be granted the opportunity for the subsequent fulfilment within a reasonable period of time.
6. If the subsequent fulfilment fails the buyer can – irrespective of possible claims for damages – cancel the contract or reduce the remuneration. The buyer can only request reimbursement for fruitless expenses if we are responsible for the defect owing to wilful intent or gross negligence.
7. Defects shall not exist with an only insignificant deviation from the agreed conditions, with an only insignificant impairment to the usability, with natural wear and tear or damages, which are caused after the risk has passed as a result of faulty or negligent treatment, excessive use, unsuitable operating equipment or owing to special external influences, which are not presumed according to the contract, as well as with software faults that cannot be reproduced. If improper changes or repair work is carried out by the buyer or by third parties then this and the thus incurred consequences shall not substantiate any defects either. The same shall apply if our stipulations concerning the handling and other instructions are not complied with and a proper maintenance is not carried out.
8. Claims of the buyer owing to the expenses, which are necessary for the purpose of the subsequent fulfilment, in particular transport, route, labour and material costs, are excluded if the expenses increase, because the object of the delivery has subsequently been taken to another location than the buyer's branch unless the transportation corresponds with its use as intended.
9. Statutory claims for recourse of the buyer against us shall only exist to the extent that the buyer has not reached any agreements with its buyer that go beyond the statutory claims for defects.
10. Subclause 9 shall apply to claims for damages. Further or other than claims regulated in this Subclause or in Subclause 9 owing to a quality defect are excluded.

§ 9 Industrial property rights and copyrights, defects of title

Insofar as not otherwise agreed, we are obliged to merely provide the delivery in the country of the place of delivery free of industrial property rights and copyrights of third parties (hereinafter property rights). Insofar as a third party asserts justified claims owing to the infringement of property rights due to deliveries provided by us and used as per contract against the buyer, we shall be liable towards the buyer as follows within the deadline determined in Subclause 8.2:

1. We will, at our choice and at our costs, either obtain a right of use for the deliveries concerned, change these so that the property right is not infringed, or exchange these. If this is not possible for us at reasonable conditions, the buyer shall be entitled to the statutory rights to cancellation or reduction. The buyer can only request reimbursement for fruitless expenses if we are responsible for wilful intent or gross negligence. Our obligation to pay compensation is oriented to Subclause 10.
2. The aforementioned obligations shall only exist if the buyer informs us immediately in writing about the claims asserted by third parties, does not recognise an infringement and we reserve the right to all defence measures and settlement negotiations. If the buyer discontinues the use of the delivery for reasons to minimise damages or for other important reasons he undertakes to inform the third party that the discontinuation of the use is not associated with a recognition of an infringement of a property right.
3. Claims of the buyer are excluded insofar as he is responsible for the infringement of property right.

4. Claims of the buyer are further excluded insofar as the infringement of property right is caused by special stipulations of the buyer, due to an application that is not foreseeable for us or by the fact that the delivery is changed by the buyer or is used together with products not delivered by us.

5. In the event of infringements of property rights the provisions of Subclauses 8.4, 8.5 and 8.9 shall apply accordingly to the claims of the buyer regulated in Subclause 13.

6. Further or other claims of the buyer against us or our vicarious agents owing to a defect of title than those regulated in this Subclause 9 are excluded.

§ 10 Joint and several liability

1. Claims of the buyer for damages – irrespective of the legal nature of the asserted claim – are excluded.
2. Excluded from this are:
 - a) Damages owing to the breach of essential contractual obligations. Deemed as essential are such contractual obligations, the fulfilment of which makes the proper execution of the contract possible at all and on the compliance with which the contractual partner may as a rule rely and depend on.
 - b) Damages from the injury to life, the body or the health if we are responsible for the breach of obligation.
 - c) For other damages, which are due to a wilful or grossly negligent breach of duty, whereby our breach of duty is deemed equivalent to that of our legal representatives or vicarious agents.
 - d) Liability according to the ProdHaftG [German Product Liability Act]
3. A change to the burden of proof for the disadvantage of the buyer is not associated with the afore-mentioned regulations.
4. Insofar as the liability for damages is excluded or limited against us, this shall also apply with regard to the personal liability for damages of our employees, our commercial agents and our vicarious agents.

§ 11 Obligations of the buyer to provide assistance

1. Assistance services of the buyer, which are explicitly or tacitly agreed within the framework of the contract, shall be carried out without a special remuneration unless explicitly otherwise agreed.
2. The buyer is obliged to inform us about all facts in time, from which it can be derived that goods and products in stock in our company, which we have made available with regard to the production capacities reported to us, cannot be used or not used in full. If residual stocks remain the buyer shall take over the stocks and the, if applicable incurred destruction costs in the event of a premature change to its material scheduling. This shall also apply to products, with which we had to order minimum quantities on the part of our suppliers if we have informed the customer hereof in advance.
3. The buyer guarantees that the products supplied by him for processing are suitable for this purpose. We are not obliged to examine the products supplied by the buyer for the condition and the suitability for the further processing. Within the framework of ongoing business relationships as well as if an object for processing has initially been inspected, tested and released, the buyer undertakes to inform us of each product change without request in writing. In the case of regular processing of objects the buyer is further obliged to examine the object that is to be processed by us for deviations and changes for each change to the production conditions and in his company, in particular with the exchange of tools, machines or with the introduction of new production processes and to notify us of such changes and modifications in writing.
4. We do not have to examine the instructions of our buyers, the material selection or other regulations, which are made by our buyer, for their accuracy.
5. Therefore, the buyer has to examine all instructions, which he issues as well as the quality of the materials stipulated or made available to us for the compliance with the statutory and technical regulations.
6. If the buyer is in default with regard to his obligation for provision or to provide assistance after a written warning we are entitled to the statutory rights.
7. Goods may only be returned with the supplier's express permission. Any returned goods must be delivered free in their original packaging and must be accompanied by the return receipt provided by the supplier. The goods must be in their original state, i.e. undamaged and fully functional. Returned goods will no longer be accepted when six months have lapsed from the date of delivery. Returns of specially designed or custom-made items, as well as used goods will not be accepted. We will charge a handling fee of 20 % - 40 % of the value of the goods, however, at least EUR 100 per item plus statutory VAT. Following presentation of appropriate evidence, the supplier reserves the right to charge a higher amount to the purchaser in individual cases; the purchaser is free to prove that the damage was lower.

§ 12 Place of performance and place of jurisdiction/miscellaneous

1. The place of performance and place of payment is the registered seat of our company in Sontheim/Brenz.
2. The law of the Federal Republic of Germany is to be exclusively applied to the contractual relationship. The application of the Convention of the United Nations of 11 April 1980 concerning Contracts for the International Sale of Goods (CISG „Law governing the sale of goods of Vienna“) is excluded.
3. With all disputes ensuing from the contractual relationship, if the orderer is a merchant, a legal entity under public law or a special fund under public law, the action is to be filed at the court that has jurisdiction for our headquarters. We are also entitled to file action at the headquarters of the orderer.
4. We store your data according to Section 23 Federal Data Protection Act.

RÖHM GmbH

89565 Sontheim (Germany)

Status: July 2019

General Service Terms (ASB) of RÖHM GmbH, Sontheim

1. Validity

1.1 These ASB form the basis for all business transactions with our customers, which refer to the repair or maintenance of the products manufactured or delivered by us insofar as these customers concern entrepreneurs within the meaning of Section 14 BGB [German Civil Code].

1.2 Contradictory, supplementary contractual terms and conditions of the customer or those which deviate from these ASB will not be recognised.

1.3 Within the framework of a regular business relationship these ASB will also be valid after the effective inclusion for the first time if we do not explicitly refer hereto in follow-up transactions.

1.4 Insofar as the ASB do not include any regulations, the General Terms of Sale and Delivery of RÖHM GmbH shall apply.

2. Offer and conclusion of the contract

2.1 Our offers are – insofar as not explicitly marked as binding – without obligation and merely to be understood as invitatio ad offerendum. The right is reserved to an interim sale.

2.2 Contracts with us will only be concluded with our written acceptance declaration or – if such is not carried out – by our delivery and service. Changes and supplementations to the contracts concluded with us require a written form.

2.3 If the object of maintenance or repair was not delivered by us then the customer has to point out existing industrial property rights with regard to the object if we are not responsible for any fault the customer shall indemnify us from possible claims of third parties from industrial property rights.

2.4 Insofar as we are responsible for negligence Par. 2.3 shall apply accordingly.

3. Contractual parts

The offer and the product list respectively available to us and the customer are a part of the contract.

4. Technical documents and plans

4.1 All rights to our offer documents as well as documents, which have been handed over, shall remain reserved.

4.2 The customer shall recognise our rights and will not reproduce the documents in full or in part, not make these accessible to third parties or use these for any other purpose than that for which they were handed over to him without our prior written authorization.

5. Scope of services, maintenance, condition of device, repair

5.1 Decisive for the scope of our delivery and service is our binding offer or – if such is not available – our written declaration of acceptance. Both individual services can be agreed, which are principally to be remunerated according to Subclause 12.1, as well as the service packages described under Subclause 5.2, which are to be remunerated according to 12.2 respectively 12.3.

5.2 The following activities are a part of our service obligation with the processing of service packages:

5.2.1 Commissioning of service

- skilled execution of the necessary commissioning of the clamping device and control at the place of installation in line with the regulations of the manufacturer.
- assembly work over the course of the commissioning together with the machine manufacturer
- first instructions and operator training
- we will invoice separate requests for the training with regard to the maintenance and use as separate work.

5.2.2 Inspection service

Skilled execution of the necessary inspection of the clamping device and control at the place of installation in line with the regulations of the manufacturer. Insofar as additional maintenance or repairs become necessary at the customer's request or owing to special loads, these are to be remunerated separately by the customer.

5.2.3 Maintenance service

Skilled execution of the necessary maintenance of the clamping device and control at the place of installation in line with the regulations of the manufacturer. Insofar as additional repairs become necessary at the customer's request or owing to special loads, these are to be remunerated separately by the customer.

5.3 The service obligation shall begin with the purchase or conclusion of a service package. With the purchase or conclusion of a service package after the expiry of the warranty period the service obligation of RÖHM shall only refer to such products, which are capable of use and free of defects at the time of the conclusion or purchase of the service package. This is to be ensured by an inspection of the products; if defects are determined these are to be remedied before the start of validity of the service package by a necessary repair liable to costs; this repair is not part of the service package.

5.4 Our service obligation shall not include carrying out work on products and accessories, which was(were) not delivered by us.

5.5 Our service obligation shall lapse if the product was not subjected to the function and safety tests according to the details in the operating instructions or third parties have carried out work on the products concerned without our prior written consent unless this work has no disadvantageous influence on the provision of our service. The same shall apply if the products have been damaged due to causes for which we are not responsible, for example by water, fire, stroke of lightning or other implications of force majeure as well as with improper treatment by the customer or third parties.

5.6 Depending on the use and type of the product an overhaul may be necessary after longer use. This is the case if the costs of a repair exceed the current value of the product. Overhaul within this meaning is also the necessary new acquisition of a product in the absence of available spare parts. Overhauls are not part of the service obligation within the service packages. If we are of the opinion that a products that is to be maintained by us under a service package requires an overhaul, we will inform the customer hereby by stating the current value estimated by us and submit an offer for the overhaul to the customer with a remuneration calculated according to 12.1.

6. Repair/service that cannot be carried out

6.1 The services provided concerning the details of a cost estimate as well as the further incurred and to be proven work (fault search time equal to working hours) will be invoiced to the customer if the repair cannot be carried out due to reasons for which RÖHM GmbH is not responsible, in particular because the fault for which a complaint will be made did not occur during the inspection, spare parts cannot be procured, the customer culpably missed the agreed date or the contract was terminated during the execution.

6.2 The object of repair only needs to be restored to the original condition again at the explicit request of the customer against reimbursement of the costs unless the undertaken work was not necessary.

6.3 In case of a repair that cannot be carried out RÖHM GmbH shall not be liable subject to sentence 2 for damages to the object of repair, the breach of contractual secondary obligations and for damages, which were not suffered to the object of repair itself, no matter to which legal grounds the customer refers. RÖHM, on the other hand, will be liable in case of wilful intent, with gross negligence of the owner / the executive bodies or executives as well as with the culpable breach of essential contractual duties. Such contractual obligations are deemed essential, the fulfilment of which makes the proper execution of the contract possible at all and the compliance with which the contractual partner may as a rule rely and depend upon.

7. Duration of the service

7.1 The details with regard to the duration of repairs and services are based upon estimates and merely serve as information and a first estimate by the customer. They are therefore not binding if they have not been explicitly marked as binding.

7.2 In case of subsequently placed additional and extension orders or with necessary additional repair work the agreed repair deadline shall be extended accordingly.

8. Obligations to provide assistance of the customer

8.1 The customer has to draw our attention to the statutory, official and company safety and other regulations applicable at the place of destination of our delivery and service, which refer to the delivery, the assembly and the operation.

8.2 The customer will inform us with or immediately after his order about possible special features of the place of installation, which may have an implication on the proper function of the products, in particular about the structural condition and the concrete operating environment.

8.3 The customer shall ensure – also during the warranty period according to Subclause 17.5 – a regular and skilled maintenance of the products delivered by us insofar as this was not taken over by us as per contract.

8.4 The customer shall dispose of the goods delivered by us at his own responsibility and at his own costs according to the respective valid regulations. We are not obliged to create a possibility for the return unless this would have been stipulated by law.

8.5 The customer has to support the repair / maintenance personnel with the execution of the repair at his own costs.

8.6 The customer has to take the special measures, which are necessary for the protection of persons and objects at the workplace. He also has to inform the repair managers about existing special safety regulations insofar as these are of significance for the repair personnel. He shall inform us in case of breaches of the repair personnel of such safety regulations. In case of serious breaches he can refuse the infringing party access to the repair location by mutual agreement with the repair manager.

8.7 The customer shall bear a supervisory and assistance obligation for the compliance with the statutory working time limits. Breaches are to be reported to RÖHM GmbH.

8.8 The customer is obliged to provide the reasonable and necessary technical assistance at his costs, in particular to:

- a) Provision of the necessary, suitable assistants in the number that is necessary for the repair and for the necessary time; the assistants have to follow the instructions of the repair manager. We do not assume any liability for the assistants. If a defect or damages were caused by the assistants owing to instructions of the repair manager, then the regulations of Sections 17 and 18 shall apply accordingly.
- b) Undertaking of all construction, bedding and scaffolding work including the procurement of the necessary building materials.
- c) Provision of the necessary devices and heavy tools as well as the necessary commodities and required materials.
- d) Provision of heating, lighting, operating power, water, including the necessary connections.
- e) Provision of necessary, dry rooms, which can be locked for the storage of the tool for the repair personnel.
- f) Protection of the repair place and materials against harmful influences of all kinds, cleaning of the repair place.
- g) Provision of suitable, theft-proof recreation rooms and work rooms (with heating, lighting, washing possibility, sanitary facilities) and First Aid for the repair personnel.
- h) Provision of the materials and undertaking of all other acts, which are necessary for the adjustment of the object of repair and for carrying out a testing that is envisaged as per contract.

8.9 The technical assistance of the orderer must guarantee that the service can be started immediately after the arrival of our personnel and carried out without delay until the acceptance by the orderer. Insofar as special plans or instructions of RÖHM are necessary, RÖHM shall make these available to the orderer in time.

9. Obligations of the customer to provide assistance in case of maintenance

9.1 The products are to be used as intended and according to their protection type and in line with the operating instructions together with their annexes.

9.2 In case of an agreement of one of the service packages described in Subclause 5, the customer will place the products that are to be installed, maintained or repaired into a faultless condition, capable of use before conclusion of the contract at his own costs if the products are not already in such a condition. If the customer does not properly satisfy this obligation either after a warning on our part and within the deadline we are entitled to accordingly cancel the contract or the delivery. Further claims for damages on our part shall remain unaffected.

9.3 If the customer uses the maintenance service interferences are to be reported to us immediately in writing, in detail and in an understandable manner.

9.4 Our employees and vicarious agents are to be granted the unimpeded and safe access to the products. In case of delays for which the customer is responsible he is obliged to remunerate the waiting times of our employees and vicarious agents resulting from the delay separately.

9.5 The customer shall refrain from commission third parties with the services during the term of a service agreement, which we have to provide according to the agreement or from performing this work himself.

9.6 The customer has to draw our attention to the statutory, official and company safety regulations and other regulations applicable at the place of destination of our delivery and service, which refer to the delivery, the assembly and the operation.

10. Inspection and acceptance

10.1 Services will be provided by us according to the guidelines of our quality control and deliveries inspected accordingly. If the customer requests further inspections then these are to be agreed in writing and paid by the customer. This shall relate e.g. to special tests for the acceptance.



General Service Terms (ASB) of RÖHM GmbH, Sontheim

10.2 The customer undertakes to accept our services under this contract immediately after the report that they have been completed. Upon request he has to declare their acceptance in writing towards our employees or vicarious agents insofar as there is no essential defect. This is carried out by the signing of the service report.

10.3 Our services shall be deemed as accepted free of defects with the re-commencement of the operational use of the maintained or repaired product, in particular for production purposes, if no defects have been previously reported by the customer.

11. Cost details and cost estimate

11.1 The creation of the cost estimates is liable to costs if the execution of the repair is not approved.

11.2 The costs for a cost estimate amount to the flat rates fixed in the current price list.

11.3 If the repair cannot be carried out at these costs or if our employees or vicarious agents consider the execution of additional work to be necessary during the repair the customer's consent is to be obtained if the stated costs are exceeded by more than 15%.

12. Remuneration, maturity and terms of payment

12.1 Insofar as not otherwise agreed and there is no warranty case our services are to be remunerated according to the actual work requirement pursuant to our respectively valid general price lists. The time required by our employees will be settled in time sections of 15 min. In addition to the time required for the work that is to be performed in these cases the customer will pay the travelling and waiting times, overtime surcharges, expenses, travelling and accommodation costs as well as the costs of spare parts, materials subject to wear and tear and consumables and replacement part sets according to our prices lists or in line with the offer.

12.2 Insofar as a flat rate remuneration was agreed for a service package, our work and travelling costs and expenses are thus covered, not however the costs for waiting times, overtime at the customer's request, spare parts, materials subject to wear and tear and consumables, replacement parts sets as well as other accessories. Our work for if applicable necessary repairs is to be remunerated separately by the customer according to Subclause 12.1.

12.3 The prices for our services can be derived from the respective price list valid upon conclusion of the contract and are deemed ex works plus value added tax. The calculation basis for the remuneration is the one-shift operation, i.e. a use of the products up to 160 hours in a calendar month. A surcharge to the list price of 50% is charged for the two-shift operation, a surcharge of 100% for the three-shift operation. The above two rates shall only apply to the service packages described under Subclause 5.. If the customer requests assignments outside of our normal working hours (Mo - Fr, 6:30 am - 6:30 pm, a max. of 7 h per day) surcharges will be calculated according to the respective valid price list.

12.4 If our personnel and material costs are increased then we are entitled to adjust the contractual prices after the expiry of the first year up to a maximum of 5% above the price of the previous year. Price changes will be announced to the customer at least one month before the new contractual prices come into force. The customer is entitled to terminate the contract effective as of the time at which the new price would become valid for him for the first time.

13. Transport and insurance with the repair in the plant of RÖHM GmbH

13.1 The object for repair will be delivered by the customer to us at his costs together with the repair and service form and after execution of the repair collected by the customer again or return to him at the customer's costs.

13.2 The customer shall bear the risk of transport.

13.3 At the customer's request a shipment carried out by us will be insured at the customer's costs against the insurable transport risks, e.g. theft, breakage and fire.

13.4 No insurance cover exists during the repair time in our plant. The customer has to ensure the maintenance of the existing insurance cover for the object of repair e.g. with regard to fire, pipe water, storm and machine breakage insurance. Insurance cover can only be procured for these risks at the explicit wish and costs of the customer.

13.5 In case of delay of the customer with the take-over we can charge a storage fee for the storage in our plant. The object of repair can also be stored otherwise at our discretion. The costs and risk of the storage during the delay shall be for the expense of the customer.

14. Repair deadline

14.1. The details concerning the repair deadlines are based on estimates and merely serve for the purpose of information and first orientation. They are therefore not binding unless this is explicitly agreed.

14.2. The agreement of a binding repair deadline, which must be described as binding, can only be requested by the customer if the scope of the work has been precisely determined.

14.3. The binding repair deadline will have been adhered to if by the time that it expires the object of repair is ready for take-over by the customer, in the event of a contractually envisaged testing ready for its execution.

14.4. In case of subsequently placed additional and extension orders or with necessary additional repair work the agreed repair deadline will be extended accordingly.

14.5. If the repair is delayed due to measures within the scope of industrial disputes, in particular strike and lock-out as well as the occurrence of circumstances, which were not caused by us, a reasonable extension to the repair deadline will occur insofar as such impediments have as proven a substantial influence on the completion of the repair; this shall also apply if such circumstances occur after we are in default.

15. Ban on offsetting and assignment; subcontractors

15.1 The customer is only entitled to offsetting in the event of undisputed claims or claims which have been declared final and binding. This shall not apply if the customer asserts claims in the reciprocal relationship, in particular claims for defects.

15.2 The assignment of rights of the customer from contractual relationships with us presumes our prior consent in order to be valid. This shall not apply insofar as Section 354 a HGB [German Commercial Code] applies.

15.3 We are entitled to use third parties in order to fulfil our contractual obligations.

16. Reservation of title

16.1 The goods delivered by us shall remain our property until the payment of all of our claims against the customer, no matter for what legal grounds, also future ones. In case of current account the aforementioned property shall be deemed as security for our balance claim.

16.2 The customer may only sell within the framework of his customary business transactions and neither pledge, nor assign the goods as collateral. The customer hereby

assigns us for security of our payment claims against him, in the amount of the value of our delivery and service, all claims with all secondary rights, which he acquires against his buyer owing to such a sale.

16.3 As long as the property has not yet been assigned, the customer has to inform us immediately in writing if the delivered object is attached or is exposed to other interventions of third parties. Insofar as the third party is not in the position to reimburse us the court and out-of-court costs of an action according to Section 771 ZPO [German Code of Civil Procedure] the customer shall be liable for the loss incurred to us.

16.4. We undertake to release the securities to which we are entitled at the customer's request insofar as their value exceeds the claims which are to be secured by more than 20 %."

17. Warranty

17.1 Insofar as the creation of a work has been agreed and thus the law governing contracts for work and services applies the following shall apply: If our services are faulty then we are first of all entitled and obliged to subsequent satisfaction according to Section 634 No. 1 BGB. If the subsequent satisfaction finally fails the customer can according to Section 634 No. 3 cancel the contract or reduce the remuneration and according to Section 634 No. 4 BGB request damages. Claims of the customer for reimbursement of expenses according to Section 634 No. 2 BGB (self-execution) are excluded. Subclause 18 shall apply to claims for damages.

17.2 Insofar as we provide planning services without executing these and thus the law governing service contracts applies (e.g. in the event of a breach of our duties under Subclauses 5.2.1, 5.2.2 and 5.2.3) the following applies: If our services are faulty then we are first of all entitled and obliged to subsequent improvement. If the subsequent improvement finally fails the customer is entitled to damages according to Subclause 18.

17.3 Excluded from the warranty are damages as a result of natural wear and tear, faulty maintenance – insofar as we have not carried out this maintenance as per contract, failure to comply with operating equipment regulations, excessive use, unsuitable operating equipment, chemical or electrolytic influences, faulty construction and assembly work of third parties as well as other causes, for which we are not responsible.

17.4 The warranty shall lapse if the customer or third party makes changes or repairs to our services /products without our prior written consent unless the defect is not a result thereof.

17.5 Claims of the customer owing to defects of quality and title shall become statute-barred with the expiry of 12 months after the acceptance of the work or the knowledge of defects with the provision of planning services.

18. Liability

18.1 We shall be liable to an unlimited extent in case of wilful intent and gross negligence as well as with the injury to life, the body and the health as well as with the culpable breach of essential contractual obligations. Deemed as essential are such contractual obligations, the fulfilment of which makes the proper execution of the contract possible at all and the compliance with which the contractual partner may as a rule rely and depend on.

18.3 Incidentally our liability is excluded.

18.4 A liability according to the Product Liability Act remains unaffected.

18.5 The personal liability of our legal representatives and vicarious agents is limited as our own liability according to the aforementioned provisions.

19. Term of the contract; termination

19.1 Service agreements according to Subclause 5. shall come into force when signed by both parties and shall initially apply until the end of the calendar year, that follows the year in which the contract was concluded. The contractual relationship will subsequently be extended respectively by one further year unless it is terminated by one of the parties with a period of notice of 3 months to the end of the second or a following year. Contractual relationships can be terminated on the whole or only with regard to individual products.

19.2 The right to the extraordinary termination for an important reason remains unaffected.

20. Place of jurisdiction; applicable law

20.1 With all disputes ensuing from the contractual relationship if the orderer is a merchant, a legal entity under public law or a special fund under public law, the action is to be filed at the court that has jurisdiction for our headquarters. We are also entitled to file an action at the headquarters of the orderer.

20.2 The legal relationship is subject to the law of the Federal Republic of Germany. German international private law and the Viennese Convention of the United Nations concerning Contracts for the International Sale of Goods (CISG) will not apply.

RÖHM GmbH

89565 Sontheim (Germany)

Status: October 2015

RÖHM GmbH

Heinrich-Röhm-Straße 50

89567 Sontheim/Brenz

Germany

Tel +49 7325 16 0

Fax +49 7325 16 510

info@roehm.biz

www.roehm.biz



Id.-Nr. 1178265 / 1118 AU